

AKPA®
30.yil



Kaliteyi takip etmiyor kaliteye yön veriyoruz.

Kalite bizim için vazgeçilmezdir.



Akpa Alüminyum 1987 yılında İstanbul'da kurulmuştur. Kuruluşundan bugüne kadar sürekli gelişimi dikkate alan Akpa Alüminyum yurtiçi satışı yanında dünyanın birçok ülkesine ihracat yapmaktadır. Akpa Alüminyum ürünlerini ihraç ettiği ülkelerde Akpa Alüminyum markasının bilinirliğinin artması ve hatırlanan ilk üç marka olmasının yanısıra Türkiye'nin alüminyum sektöründe bir marka olması konusunda öncü bir kuruluştur.

Akpa Alüminyum bütünlük kalite olgusunu tüm iş yapış şeklinin merkezine yerleşmiştir ve bu kalite felsefesini de CE,EC,TS EN 755-1,TS EN 755-3, TS EN 755-4, TS EN 755-5, TS EN 755-8, TS EN 755-9, TSE 5247, TS EN 12020-1, TSEK- 4922, ISO 9001, Qualicoat, Qualanod, ift. Rosenheim test belgelerine sahip olarak devam ettirmektedir.

Akpa Alüminyum pazarlama satış ve müşteri ilişkileri kapsamındaki faaliyetlerine İstanbul'da bulunan merkez binasında devam ederek müşterilerine hızlı ve etkin hizmet vermektedir. Firmamızın merkez ofisi pazarlama-satış noktası Çağlayan'da siz değerli müşterilerimize alüminyum profil, alüminyum ve plastik aksesuarları sektörümüzle ilgili makine ve hırdavat satışıyla hizmet vermektedir. Müşterilerimize tek noktada tüm ihtiyaçlarını karşılamak amacıyla yurtiçi ve yurtdışında bulunan, sektörde öncü firmaların bayilik ve yetkili distribütörlüğünü de yapmaktayız.



1987'den bugüne kadar alüminyum...



Alüminyum profil üretimi, alüminyum bilet üretimi, alüminyum kompozit panel üretimi, alüminyum-plastik aksesuar satışı şirketin başlıca faaliyet alanlarıdır. Akpa Alüminyum bünyesinde çalışan 700 kişi ile ekonomimize destek vermek başlıca amaçlarımızdandır. Müşterilerimizin tek noktada tüm ihtiyaçlarını karşılamak için konusunda uzman ve tecrübeli pazarlama ekibimiz görev yapmaktadır. Akpa ailesi müşterilerinin; ürün kalitesi ve performans beklentilerini, yenilikçi anlayışıyla sürekli geliştirerek, müşteri memnuniyetlerini arttırmayı ilke edinmiştir. Şirket ve çalışanları ile büyük bir aile olan Akpa Alüminyum; vizyonunu geliştiren alanlara, teknolojik ar-ge'si, güveni, kalitesi ve asla misyonundan taviz vermeden, dünyadaki tüm yeniliklere ayak uydurarak, her yıl genişleyen ihracatıyla da, sektörde dünyadaki önemli firmalardan biridir.

- 80 000 m² alan üzerine kurulu,
- 30 000 ton/yıl kapasiteli, Beş adet ekstrüzyon pres,
- 18 000 ton/yıl kapasiteli eloksal tesis,
- 15 000 ton/yıl kapasiteli dikey toz boyama tesisleri,
- 1500 ton/yıl kapasiteli ahşap transfer boya ünitesi,
- 4.500.000 m²/yıl Alüminyum kompozit panel üretim tesisi bulunmaktadır.





ALÜMİNYUM PROFİLLERİN GENEL TEKNİK ŞARTNAMESİ

SIRA NO	KATSAYILAR	DEĞERİ	BİRİMİ
1.	Özgül Ağırlık	2.71	gr / cm ³
2.	Kullanılan Billet	AlMgSi0.5	DIN - Almanya
		6063	BS - İngiltere
		60	ETIAL - Türkiye
3.	Genleşme Katsayısı	23.4	20 - 100 C°
4.	Elastisite Modülü	6,89	GPa
5.	Çekme Mukavemeti	215	(24 C de MPa)
6.	Uzama	% 6	Delta L / L* 100 (50 mm uzunlukta)
7.	Sertlik	70	Brinell (HB)
8.	Akma Mukavemeti	170	MPa
9.	Kesme Mukavemeti	130	MPa
10.	Boyanın Kalınlığı	> 60	Micron
11.	Eloksal Kalınlığı	> 10	Micron
	(Eloksal kalınlığı isteğe bağlı olarak 25 micron'a kadar çıkabilir.		

Boyalı profillerde, kesitlere göre birim ağırlık % 2 ~4 nispetinde artar. Mekanik özellikler T6 temperi için verilmiştir.

EN AW-6063 ALAŞIMIN KİMYASAL BİLEŞİMİ

Element	Si	Fe	Cu	Mn	Mg	Zn	Ti	Cr	Diğer Elementler	
									Herbiri	Toplam
Min.	0.20	-	-	-	0.45	-	-	-	-	-
Max.	0.60	0.35	0.10	0.10	0.90	0.10	0.10	0.10	0.05	0.15

ÜRETİLEBİLEN MAX. PROFİL BOYUTLARI

İÇİ BOŞ PROFİLLER İÇİN

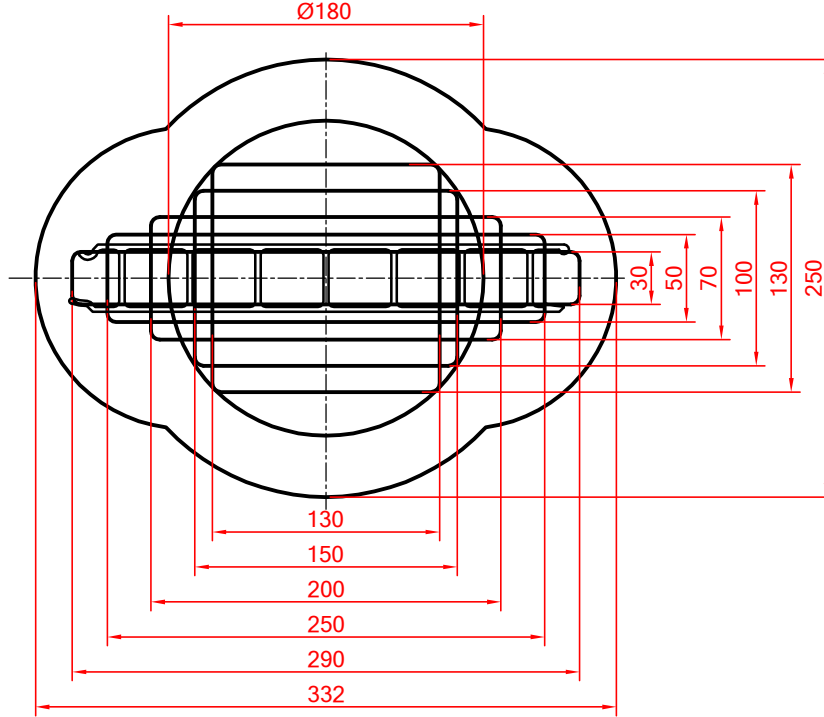

DOLU PROFİLLER İÇİN

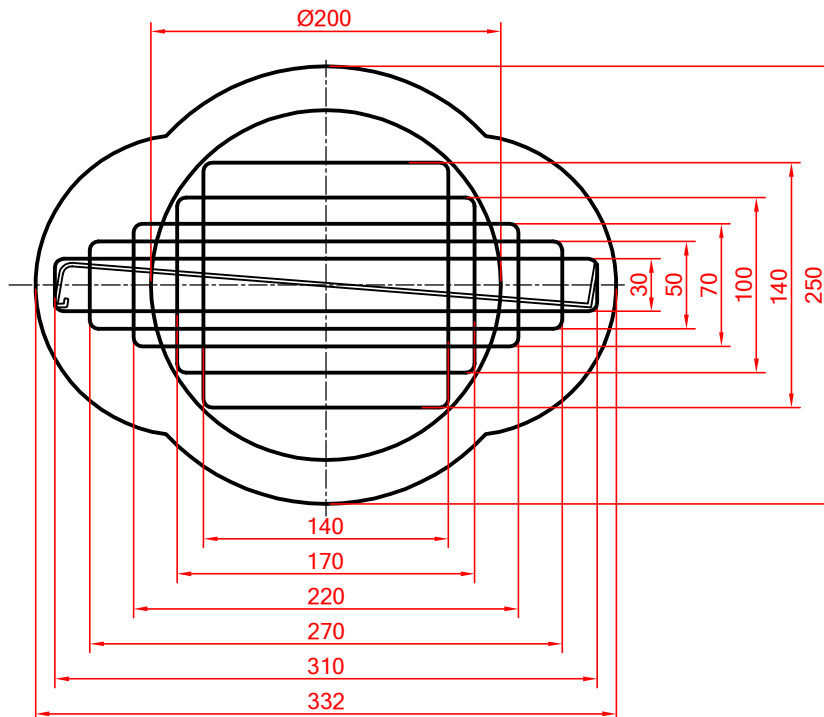

İNDEKS

PROFİL VE SERİLER	SAYFA NO	PROFİL VE SERİLER	SAYFA NO
STANDARD PROFİLLER	01 - 06	S 35 NOVOLINE SÜRME SERİSİ	55 - 56
LAMBRI ve GRİYAJ PRF.	07	HS 55 THERMO SÜRME SERİSİ	57 - 58
T BİNİ ve SİNEKLİK PROFİLLERİ	08	WD 37 SERİSİ	59 - 60
DUŞ KABİN PROFİLLERİ	09	WD 45 SERİSİ	61 - 62
JALUZİ ve BRANDA PRF.	10	WD 50 THERMO SERİSİ	63 - 64
SEHPA ve DOLAP PRF.	11	WD 55 SERİSİ	65 - 66
MOBİLYA PROFİLLERİ	12	WD 55 THERMO SERİSİ	68 - 72
DENİZLİK PROFİLLERİ	13 - 15	WD 60 SERİSİ	73 - 74
MENFEZ PROFİLLERİ	16	WD 62 THERMO SERİSİ	75 - 76
KALEBODUR, FAYANS PRF.	17	WD 64 THERMO SERİSİ	77 - 81
PANJUR PROFİLLERİ	18 - 21	WD 70 THERMO SERİSİ	82 - 83
YUVARLAK KÜPEŞTE PRF.	22 - 28	AD 40 AYARLI KAPI SERİSİ	84
KARE KÜPEŞTE PROFİLLERİ	29 - 34	AD 55 AYARLI KAPI SERİSİ	85
AKSESUAR PROFİLLERİ	35 - 38	FD 60 KATLANIR KAPI SERİSİ	86
ÖZEL PROFİLLER	39 - 42	FS 50 CEPHE SERİSİ	87 - 90
ALDOKS SERİSİ	43 - 45	FS 50 ECO CEPHE SERİSİ	91
TS 29 TUBA SÜRME (67 mm)	46	SK 50 IŞIKLIK SERİSİ	92
TS 45 TUBA SÜRME (100 mm)	47	FS 65 ÇELİK TAKVİYELİ CEPHE	93
KIBRIS SÜRME SERİSİ	48	FS 70 CEPHE SERİSİ	93
İZMİR SÜRME SERİSİ	49	SB GÜNEŞ KIRICI SERİSİ	94
S 28 SÜRME SERİSİ	50	CP 50 KOMPOZİT PANEL PRF	95
S 32 SÜRME SERİSİ	51	OP 100 OFİS BÖLME PRF	96
CS 34 SÜRME SERİSİ	52	SÜPÜRGELİK VE EŞİK PRF	97
CS 35 THERMO SÜRME SERİSİ	52	CAM BALKON SERİLERİ	98
S 38 THERMO SÜRME SERİSİ	53 - 54	SÜRME CAM BALKON SERİSİ	99

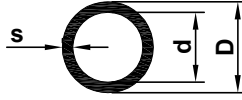

BORU

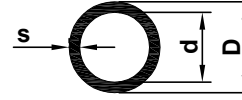
Profil No	D mm	d mm	s mm	Kg/m
3099	8	6	1.0	0.058
1047	8	5	1.5	0.083
5620	9.2	6.5	1.35	0.090
1573	10	5	2.5	0.160
6368	12	10	1.0	0.094
3098	12.5	9.1	1.7	0.156
2618	13	10.6	1.2	0.121
7356	13.9	11.1	1.4	0.149
4090	14	12	1.0	0.111
3112	14.6	10	2.3	0.241
2878	15.8	13	1.4	0.172
1234	15.8	12	1.9	0.224
492	15.8	9.8	3.0	0.327
562	15.8	9	3.4	0.359
3148	15.8	8	3.9	0.395
471	15.8	7	4.4	0.427
916	15.8	6	4.9	0.454
4133	15.8	5	5.4	0.478
6511	16	13	1.5	0.185
925	16	12	2.0	0.240
5737	17	15	1.0	0.136
6224	18	15	1.5	0.211
4349	18.15	14.15	2.0	0.275
1229	18.3	16.3	1.0	0.147
919	19	16.6	1.2	0.181
976	19	14	2.5	0.353
3097	19	13	3.0	0.409
2687	19.4	16.4	1.5	0.229
914	19.8	12.2	3.8	0.517
2563	20	18	1.0	0.163
3922	20	17.6	1.2	0.192
4901	20	16	2.0	0.307
905	20	15	2.5	0.372
1572	20	14	3.0	0.434
977	20	12	4.0	0.545
2610	20	7	6.5	0.747
915	20	5	7.5	0.795
5736	21.5	19.5	1.0	0.175
4278	22	19	1.5	0.261
4775	22	18	2.0	0.341
926	22	16.4	2.8	0.458
8039	24	21	1.5	0.287
979	24	18	3.0	0.537
698	24	16.5	3.75	0.647
699	24	14	5.0	0.810
2662	24	7	8.5	1.122
2974	24	5	9.5	1.173
918	25	22.4	1.3	0.262
3729	25	22	1.5	0.300
901	25	18.5	3.25	0.602
6887	25	10.5	7.25	1.096
7266	27	8	9.5	1.415
7260	27	10	8.5	1.339
927	27.5	22.4	2.55	0.542

BORU

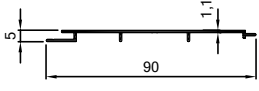
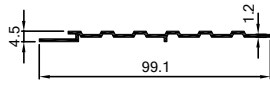
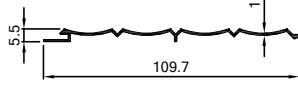
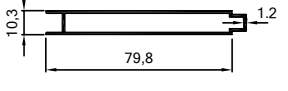
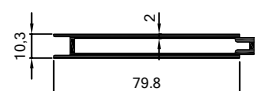
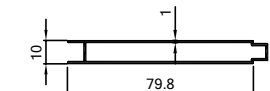
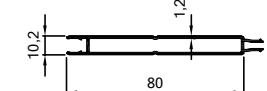
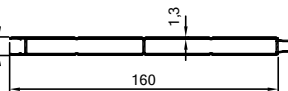
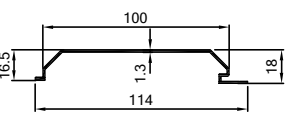
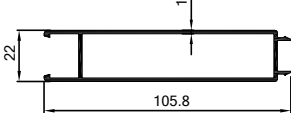
Profil No	D mm	d mm	s mm	Kg/m
4746	28	25	1.5	0.338
1582	29.5	25	2.25	0.550
906	29.5	20	4.75	0.999
3327	30	27	1.5	0.364
1571	30	26	2.0	0.477
908	30	24	3.0	0.690
978	30	22	4.0	0.886
2477	30	20	5.0	1.065
2177	30	16.5	6.75	1.336
924	30	14.1	7.95	1.492
931	30	10	10.0	1.702
3753	30	6	12.0	1.839
7402	33	25	4.0	0.988
5609	35	33	1.0	0.290
5726	35	32	1.5	0.428
3326	35	31	2.0	0.562
476	35	30.3	2.35	0.653
4778	35	30	2.5	0.692
4124	35	29.6	2.7	0.743
1575	35	29	3.0	0.817
904	35	28.5	3.25	0.879
995	35	8.5	13.25	2.452
1017	35	6.5	14.25	2.517
5667	36	30	3.0	0.843
2906	40	37.4	1.3	0.428
3826	40	36	2.0	0.647
910	40	35	2.5	0.798
8053	40	34	3.0	0.945
7403	40	32	4.0	1.226
1012	40	30.5	4.75	1.425
3839	40.2	13	13.6	3.080
1015	40.2	10	15.1	3.296
6255	44	37.5	3.25	1.128
1420	44.3	40.6	1.85	0.669
903	44.8	20.5	12.15	3.377
5666	45	37	4.0	1.396
4052	45	35	5.0	1.702
5326	45	9	18.0	4.137
2059	47	20.5	13.25	3.807
7400	48	38	5.0	1.830
755	50	47.4	1.3	0.541
2622	50	47	1.5	0.620
2984	50	46.4	1.8	0.738
896	50	46	2.0	0.817
3066	50	45.6	2.2	0.895
917	50	45	2.5	1.011
932	50	44.1	2.95	1.182
4719	50	41	4.5	1.743
8109	50	40.5	4.75	1.830
2068	50	10	20.0	5.108
3812	50	7	21.5	5.217
2938	51.5	41	5.25	2.067
2845	53	40.5	6.25	2.488
3820	53.5	50.5	1.5	0.664

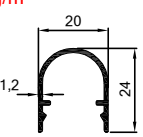

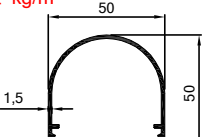
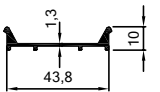
114 0.326 kg/m 	222 0.378 kg/m 	229 0.358 kg/m 	115 0.609 kg/m 
174 0.968 kg/m 	4624 0.508 kg/m 	5955 0.622 kg/m 	5956 1.254 kg/m 
5688 0.511 kg/m 	785 1.017 kg/m 		

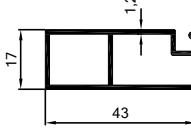
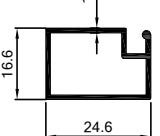
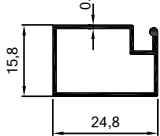
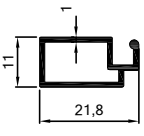
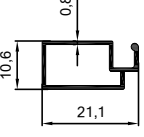
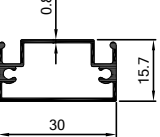
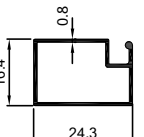
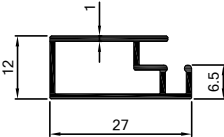
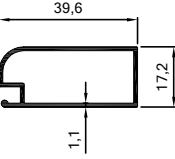
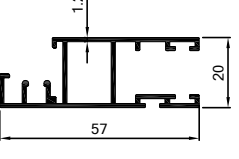
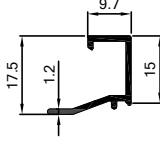
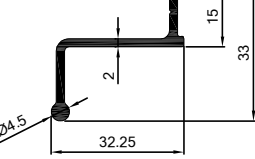
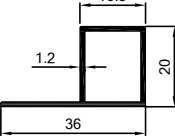
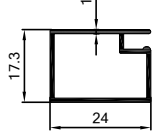
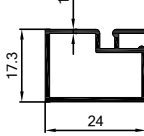
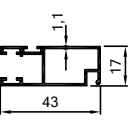
122 0.205 kg/m 	123 0.109 kg/m 	126 0.552 kg/m 	127 0.296 kg/m 

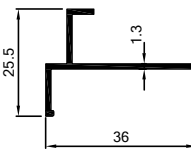
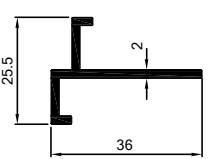
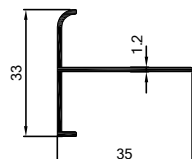
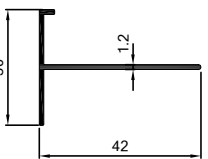
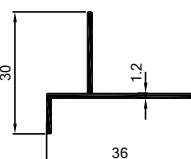
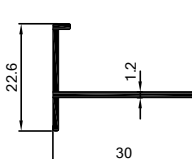
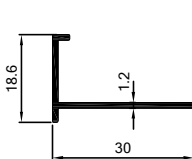
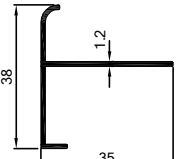
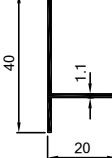
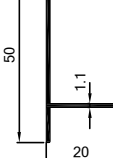
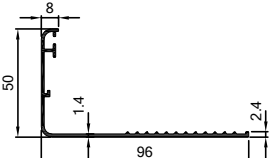
542 0.442 kg/m 	543 0.232 kg/m 	545 0.184 kg/m 	544 0.177 kg/m 
547 0.139 kg/m 	548 0.261 kg/m 	549 0.186 kg/m 	4087 0.218 kg/m 
4933 0.337 kg/m 	2276 0.609 kg/m 	2277 0.145 kg/m 	2278 0.362 kg/m 
2239 0.284 kg/m 	5719 0.232 kg/m 	5720 0.246 kg/m 	1243 0.434 kg/m 

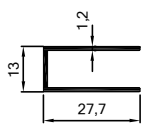
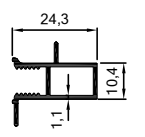
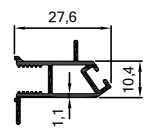
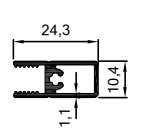
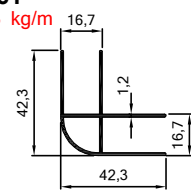
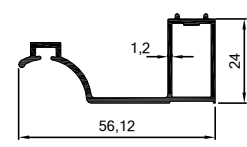
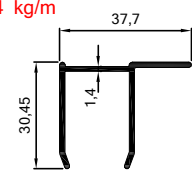
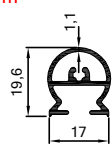
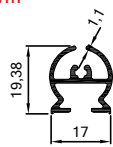
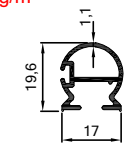
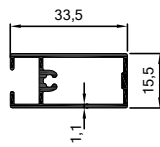
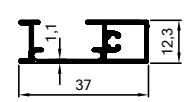
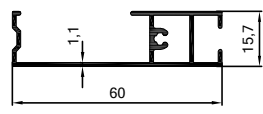
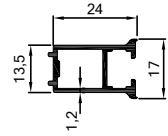
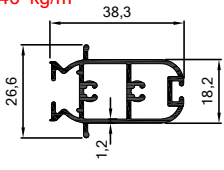
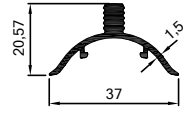
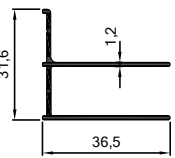
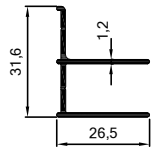
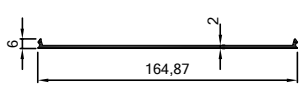
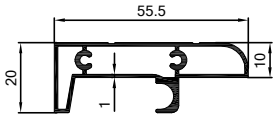
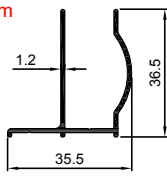
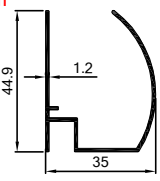
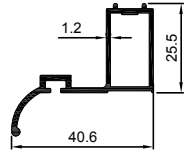
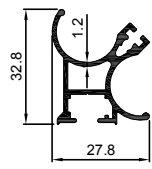
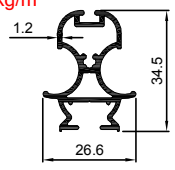
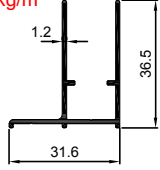
1121 0.232 kg/m 	1123 0.355 kg/m 	1139 0.239 kg/m 	1035 0.239 kg/m 
3818 0.210 kg/m 	3832 0.175 kg/m 	3917 0.162 kg/m 	7039 0.260 kg/m 
6414 0.175 kg/m 	5788 0.205 kg/m 	553 0.656 kg/m 	

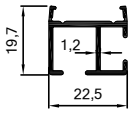
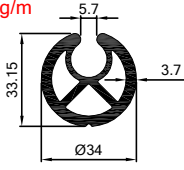

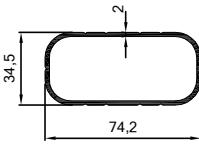
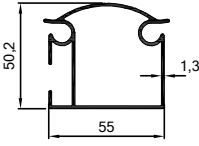
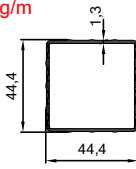
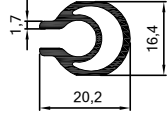
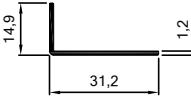
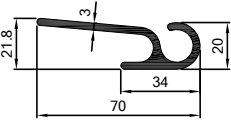

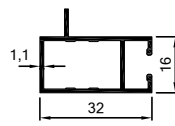
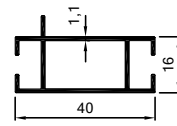
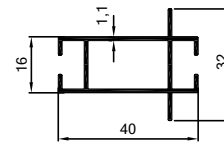
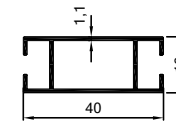
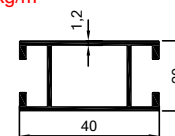
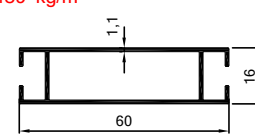
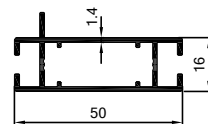
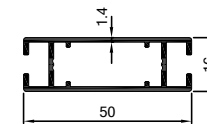
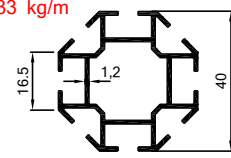
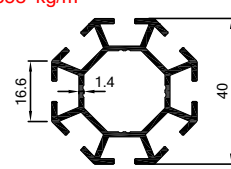
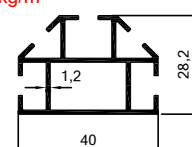
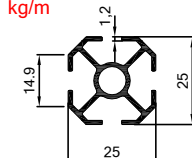
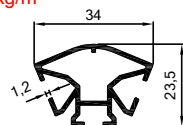
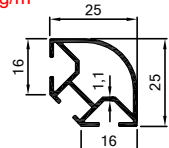
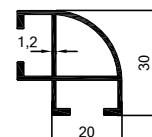
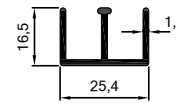
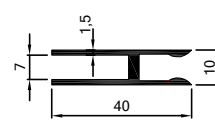
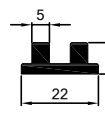
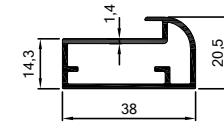
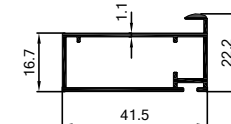
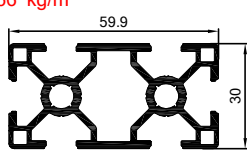
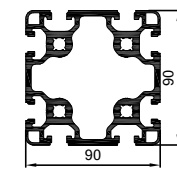
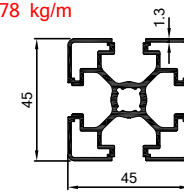
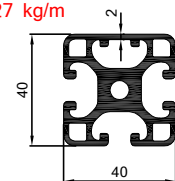
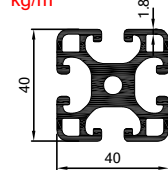
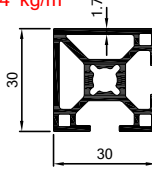
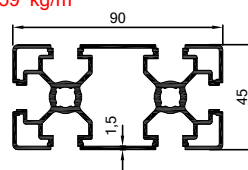
3167 0.214 kg/m 	3156 0.252 kg/m 	3157 0.276 kg/m 	3158 0.256 kg/m 
3161 0.513 kg/m 	3159 0.482 kg/m 	3151 0.384 kg/m 	3165 0.261 kg/m 
3160 0.252 kg/m 	3164 0.239 kg/m 	3166 0.342 kg/m 	3162 0.333 kg/m 
3163 0.445 kg/m 	3171 0.285 kg/m 	3150 0.546 kg/m 	3174 0.328 kg/m 
3170 0.339 kg/m 	3178 0.274 kg/m 	3173 0.926 kg/m 	6441 0.554 kg/m 
3049 0.342 kg/m 	3748 0.402 kg/m 	3050 0.429 kg/m 	3051 0.443 kg/m 
3052 0.487 kg/m 	3048 0.350 kg/m 		

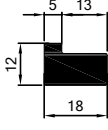
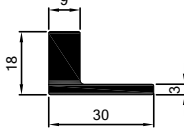
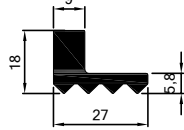
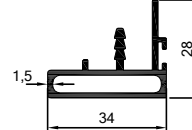
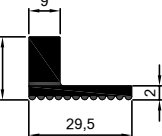
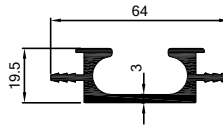
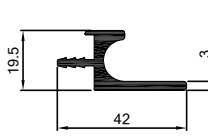
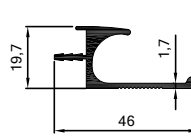
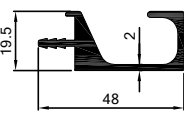
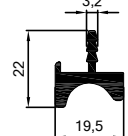
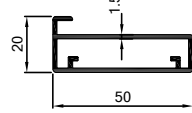
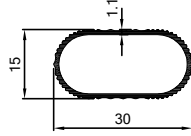
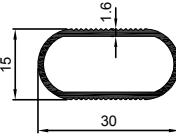
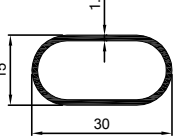
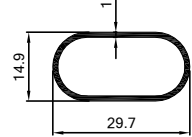
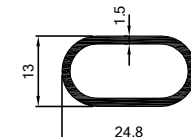
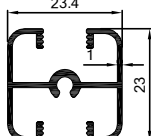
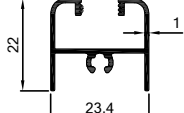
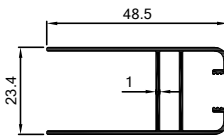
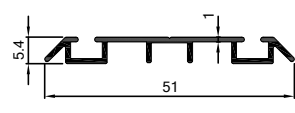
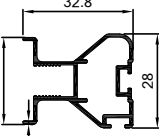
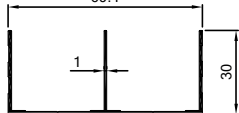
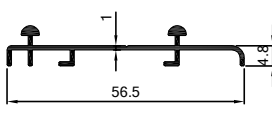
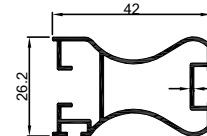
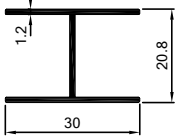
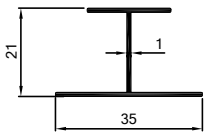
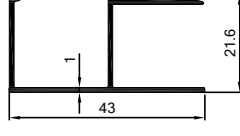
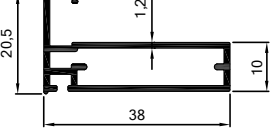
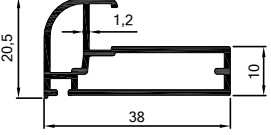
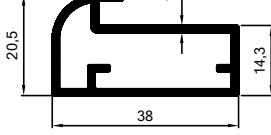
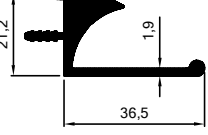
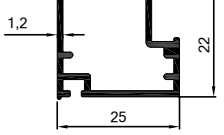
<p>118 0.058 kg/m</p> 	<p>3100 0.277 kg/m</p> 	<p>2182 1.215 kg/m</p> 	<p>3101 0.062 kg/m</p> 
<p>3108 1.020 kg/m</p> 	<p>3109 0.937 kg/m</p> 	<p>3110 0.615 kg/m</p> 	<p>3111 0.274 kg/m</p> 
<p>3092 0.145 kg/m</p> 	<p>2181 0.991 kg/m</p> 		

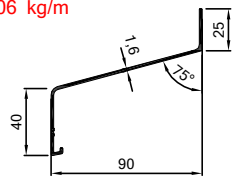
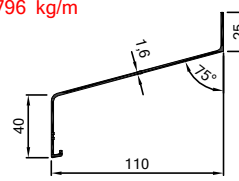
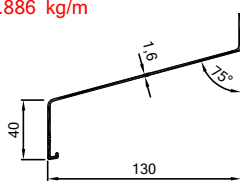
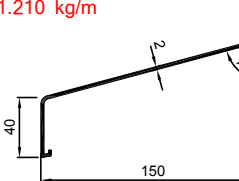
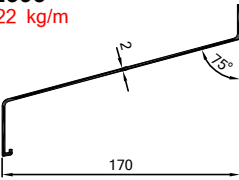
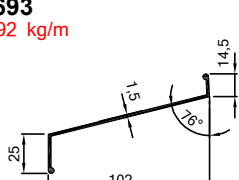
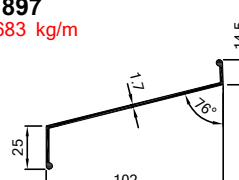
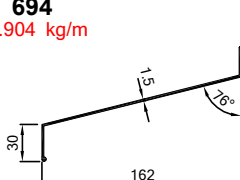
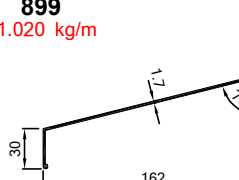
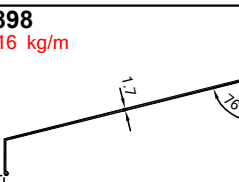
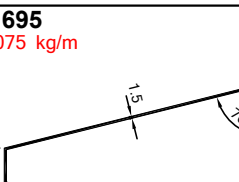
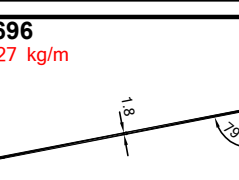
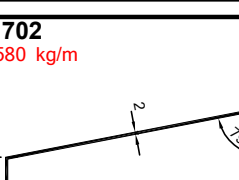
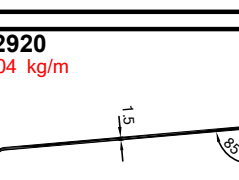
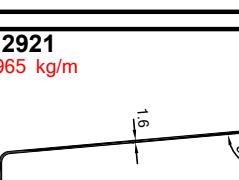
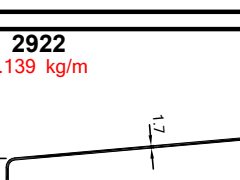
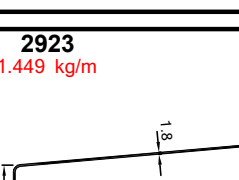
<p>121 0.334 kg/m</p> 	<p>139 0.391 kg/m</p> 	<p>314 0.409 kg/m</p> 	<p>315 0.370 kg/m</p> 
<p>199 0.464 kg/m</p> 	<p>316 0.489 kg/m</p> 	<p>474 0.584 kg/m</p> 	<p>473 0.556 kg/m</p> 
<p>311 0.733 kg/m</p> 	<p>472 0.838 kg/m</p> 	<p>312 0.577 kg/m</p> 	<p>313 0.399 kg/m</p> 
<p>317 0.430 kg/m</p> 	<p>192 0.352 kg/m</p> 	<p>200 0.437 kg/m</p> 	<p>177 0.327 kg/m</p> 
<p>155 0.372 kg/m</p> 	<p>176 0.340 kg/m</p> 	<p>1401 0.464 kg/m</p> 	<p>5907 0.398 kg/m</p> 
<p>7075 1.366 kg/m</p> 	<p>7076 6.087 kg/m</p> 	<p>5371 1.278 kg/m</p> 	<p>1051 1.827 kg/m</p> 
<p>1050 1.781 kg/m</p> 	<p>1269 0.864 kg/m</p> 	<p>6128 2.359 kg/m</p> 	

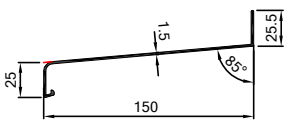
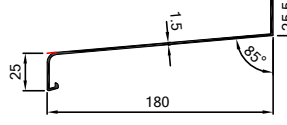
324 0.479 kg/m 	325 0.610 kg/m 	326 0.615 kg/m 	327 0.529 kg/m 
328 0.633 kg/m 	329 0.992 kg/m 	330 0.576 kg/m 	3118 0.450 kg/m 
333 0.751 kg/m 	331 0.395 kg/m 	332 0.587 kg/m 	3356 0.185 kg/m 
1679 0.264 kg/m 	2202 0.238 kg/m 	5629 0.217 kg/m 	6348 0.243 kg/m 
523 0.311 kg/m 	524 0.259 kg/m 	525 0.424 kg/m 	526 0.237 kg/m 
527 0.399 kg/m 	528 0.462 kg/m 	529 0.274 kg/m 	4932 0.455 kg/m 
515 0.254 kg/m 	5653 0.200 kg/m 	3030 0.343 kg/m 	1362 0.388 kg/m 
1363 0.421 kg/m 	1401 0.464 kg/m 	1400 0.606 kg/m 	1364 0.357 kg/m 

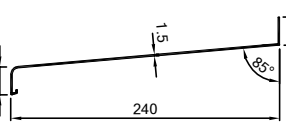
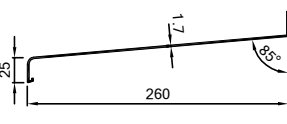
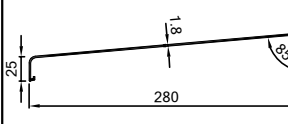
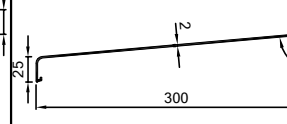
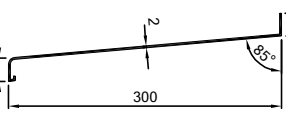
<p>2485 0.706 kg/m</p> 	<p>2484 0.796 kg/m</p> 	<p>2483 0.886 kg/m</p> 	<p>2497 1.210 kg/m</p> 
<p>2393 1.322 kg/m</p> 			
<p>693 0.592 kg/m</p> 	<p>897 0.683 kg/m</p> 	<p>694 0.904 kg/m</p> 	<p>899 1.020 kg/m</p> 
<p>898 1.216 kg/m</p> 	<p>695 1.075 kg/m</p> 		
<p>696 1.427 kg/m</p> 	<p>702 1.580 kg/m</p> 		
<p>2920 0.804 kg/m</p> 	<p>2921 0.965 kg/m</p> 	<p>2922 1.139 kg/m</p> 	<p>2923 1.449 kg/m</p> 

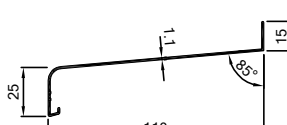
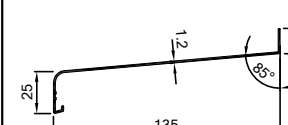
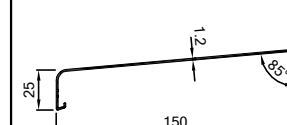
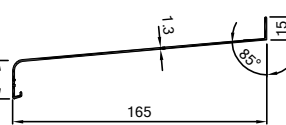
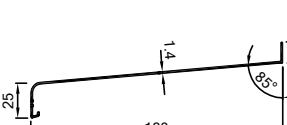
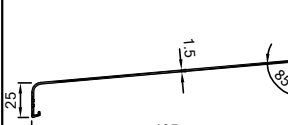
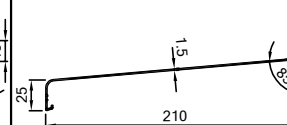
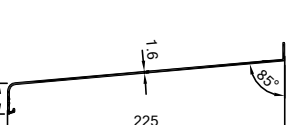
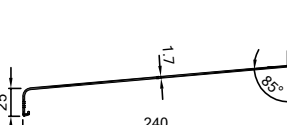
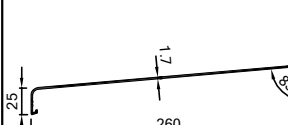
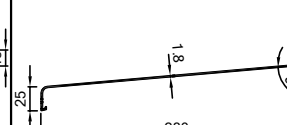
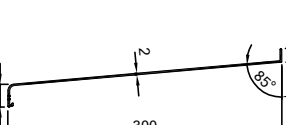

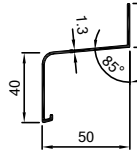
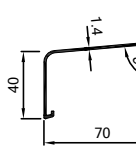
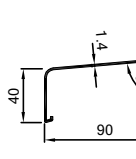
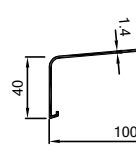
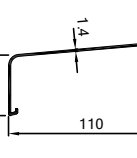
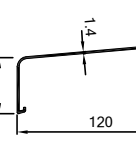
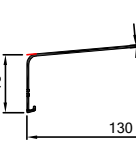
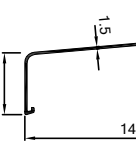
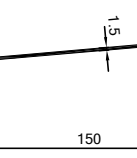
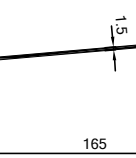
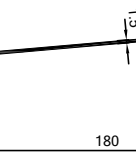
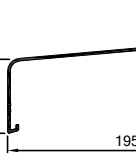
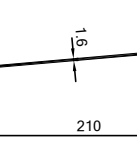
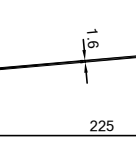
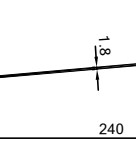
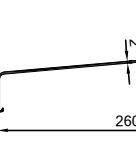
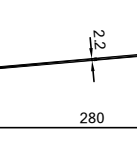
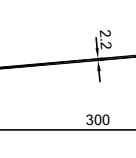

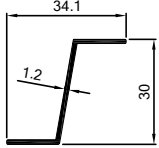
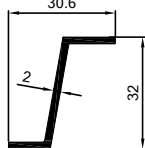
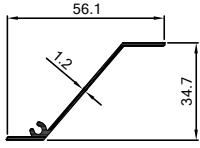
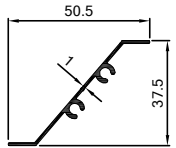
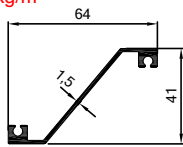
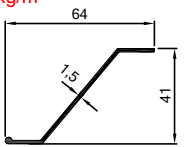
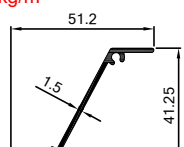
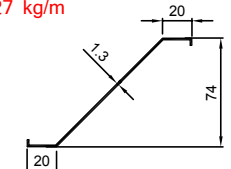
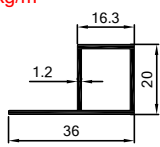
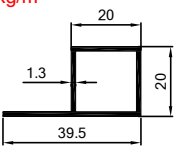
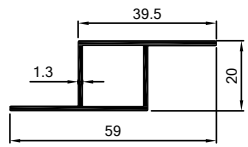
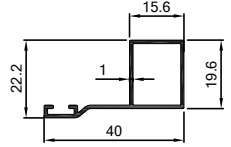
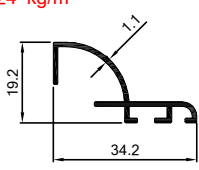
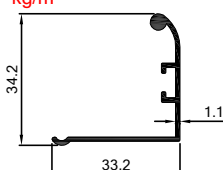
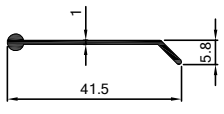
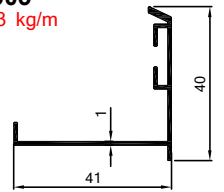
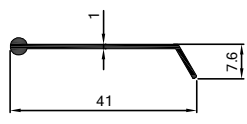
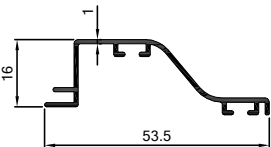
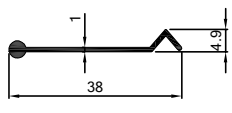
1204 0.853 kg/m 	697 0.976 kg/m 	5930 0.996 kg/m 	5774 1.053 kg/m 
5775 1.188 kg/m 	5776 1.436 kg/m 	5777 1.616 kg/m 	5778 1.900 kg/m 
2924 1.921 kg/m 			
570 0.428 kg/m 	571 0.458 kg/m 	572 0.580 kg/m 	573 0.629 kg/m 
574 0.733 kg/m 	575 0.845 kg/m 	582 0.964 kg/m 	576 1.026 kg/m 
577 1.157 kg/m 	578 1.297 kg/m 	579 1.390 kg/m 	580 1.567 kg/m 
581 1.846 kg/m 			

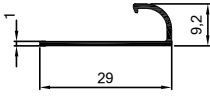
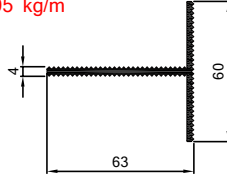
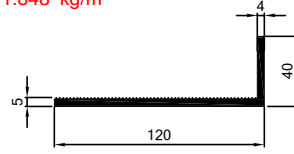
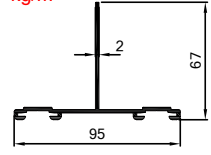
6281 0.417 kg/m 	6282 0.515 kg/m 	6283 0.591 kg/m 	6284 0.630 kg/m 
6285 0.667 kg/m 	6286 0.705 kg/m 	2424 0.802 kg/m 	6287 0.828 kg/m 
2425 0.883 kg/m 	2426 0.945 kg/m 	2427 1.006 kg/m 	2428 1.137 kg/m 
6288 1.186 kg/m 	6289 1.252 kg/m 	6290 1.457 kg/m 	6291 1.759 kg/m 
6292 2.017 kg/m 	6343 2.168 kg/m 		

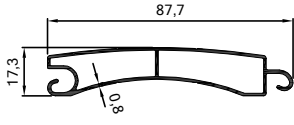
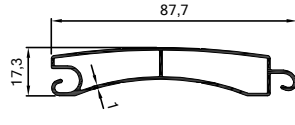
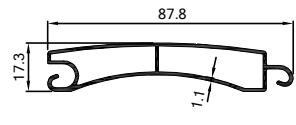
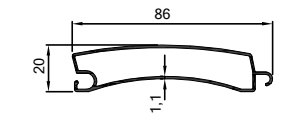
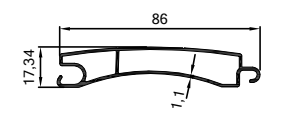
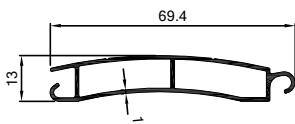
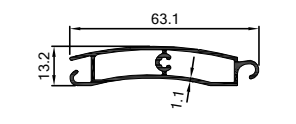
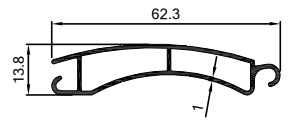
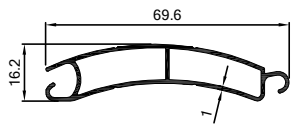
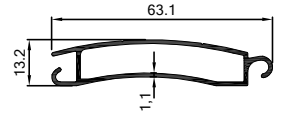
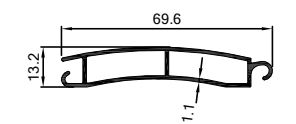
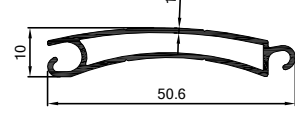
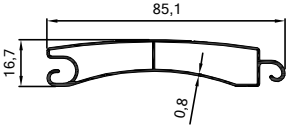
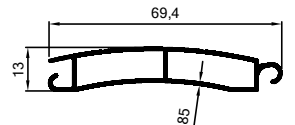
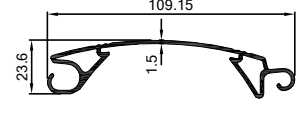
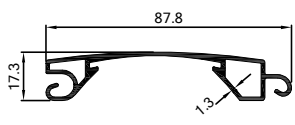
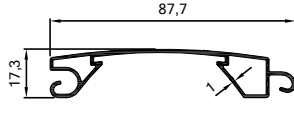
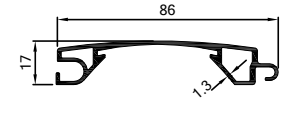
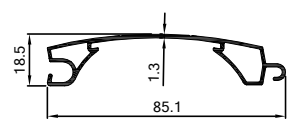
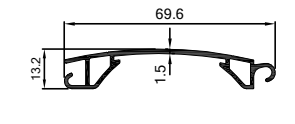
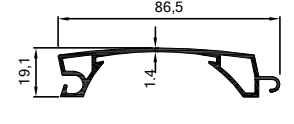
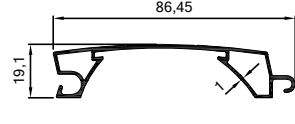
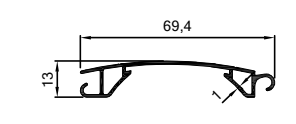
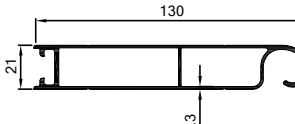
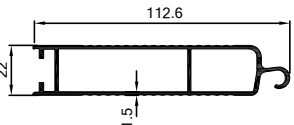
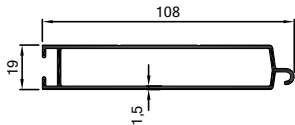
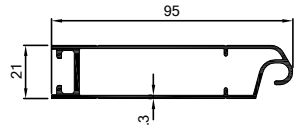
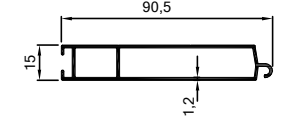
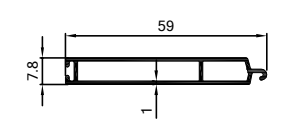
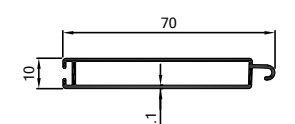
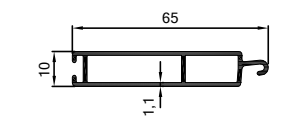
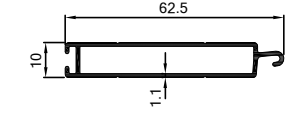
<p>5479 0.189 kg/m</p> 	<p>3840 0.299 kg/m</p> 	<p>4070 0.273 kg/m</p> 	<p>4904 0.264 kg/m</p> 
<p>1034 0.542 kg/m</p> 	<p>175 0.345 kg/m</p> 	<p>3848 0.353 kg/m</p> 	<p>3078 0.527 kg/m</p> 
<p>2239 0.284 kg/m</p> 	<p>2852 0.337 kg/m</p> 	<p>2851 0.411 kg/m</p> 	<p>5685 0.270 kg/m</p> 
<p>550 0.224 kg/m</p> 	<p>551 0.267 kg/m</p> 	<p>552 0.146 kg/m</p> 	<p>4905 0.293 kg/m</p> 
<p>3836 0.142 kg/m</p> 	<p>5684 0.270 kg/m</p> 	<p>5683 0.132 kg/m</p> 	

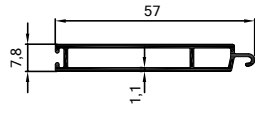

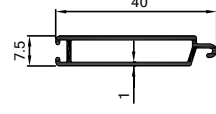
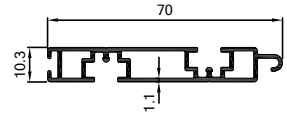
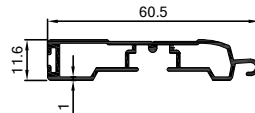
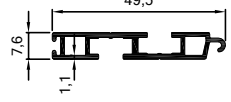
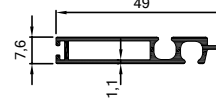
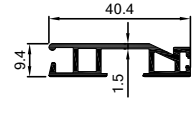
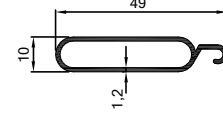
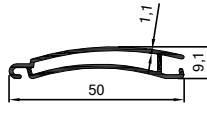
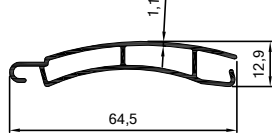
154
0.116 kg/m**2159**
0.895 kg/m**2158**
1.848 kg/m**988**
1.016 kg/m

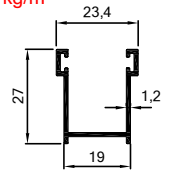
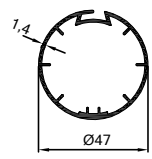
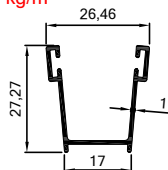
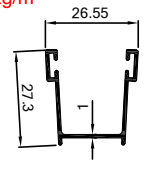
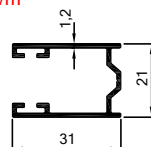
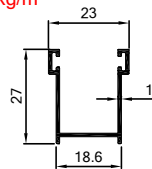
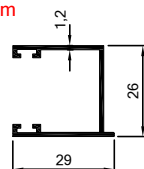
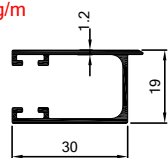
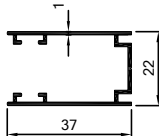
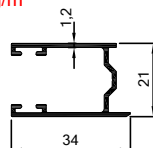
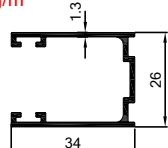
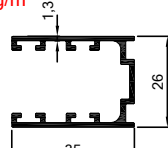
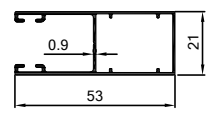
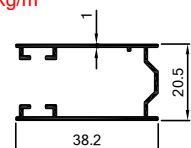
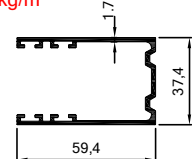
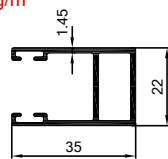
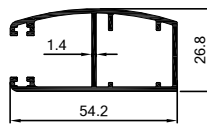
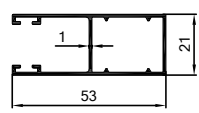
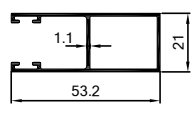
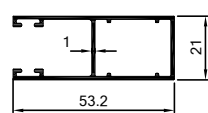

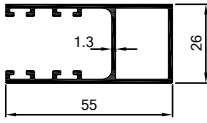
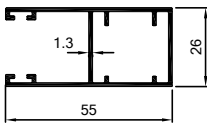
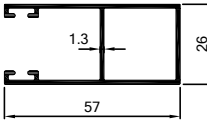
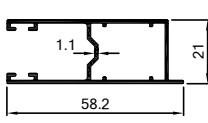
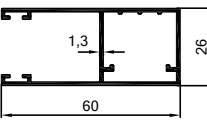
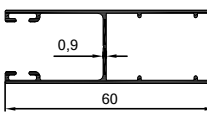
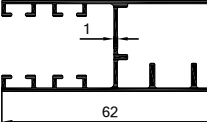
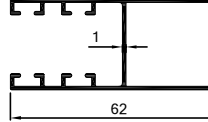
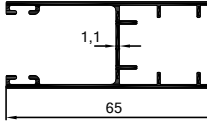
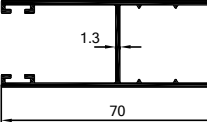
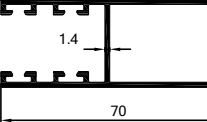
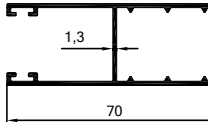
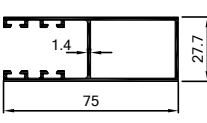
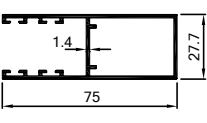
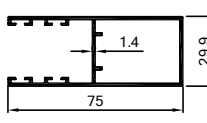
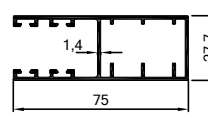
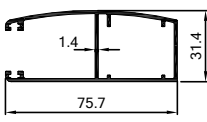
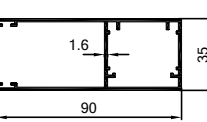
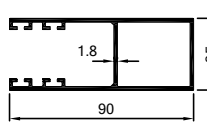
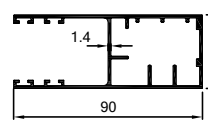
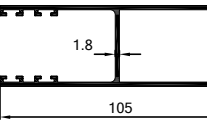
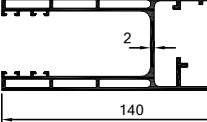
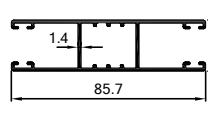
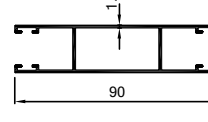
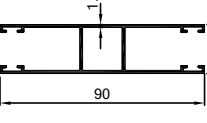
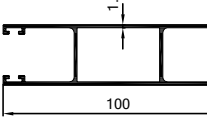
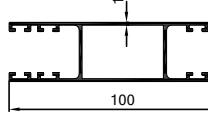
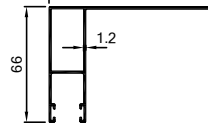
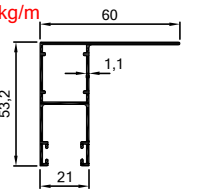
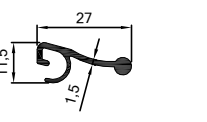
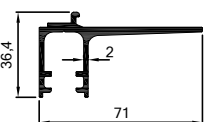
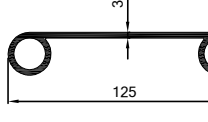

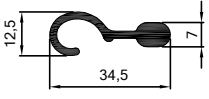
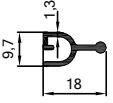
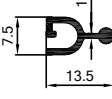
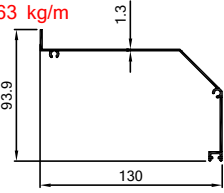
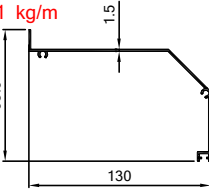
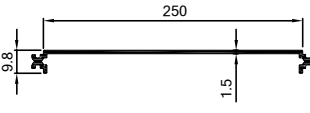
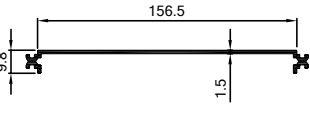
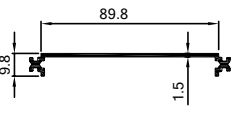
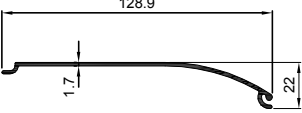
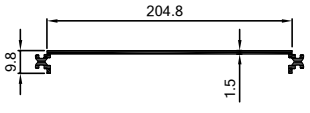
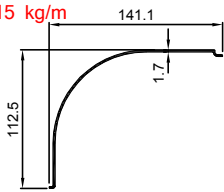
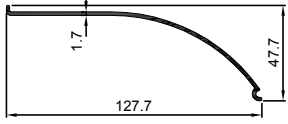
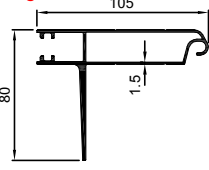
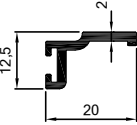
583 0.524 kg/m 	3465 0.623 kg/m 	3454 0.688 kg/m 	3430 0.615 kg/m 
3421 0.669 kg/m 	3467 0.455 kg/m 	4253 0.490 kg/m 	3471 0.423 kg/m 
3472 0.466 kg/m 	3428 0.438 kg/m 	3460 0.500 kg/m 	3374 0.315 kg/m 
6061 0.514 kg/m 	7581 0.393 kg/m 	6039 0.938 kg/m 	3455 0.748 kg/m 
3466 0.583 kg/m 	3434 0.740 kg/m 	3485 0.555 kg/m 	3461 0.458 kg/m 
3431 0.760 kg/m 	3469 0.579 kg/m 	3468 0.400 kg/m 	3371 1.280 kg/m 
3483 1.133 kg/m 	3444 1.019 kg/m 	3409 0.931 kg/m 	3425 0.720 kg/m 
5392 0.367 kg/m 	3426 0.462 kg/m 	3406 0.456 kg/m 	3361 0.415 kg/m 

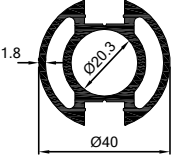
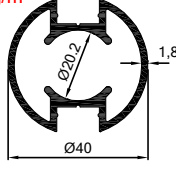
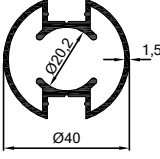
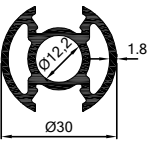
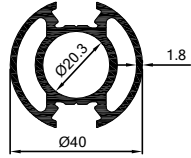
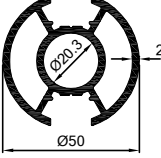
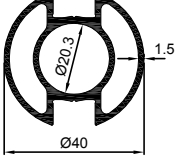
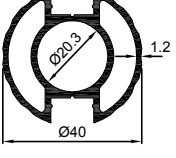
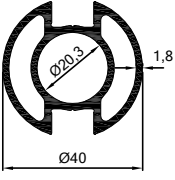
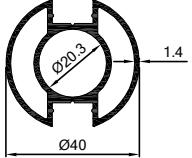
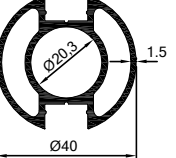
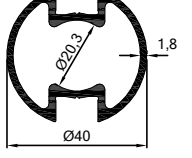
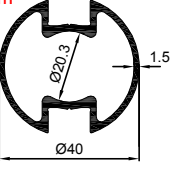
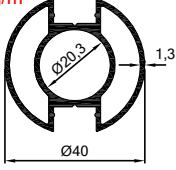
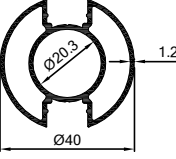
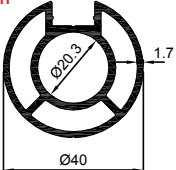
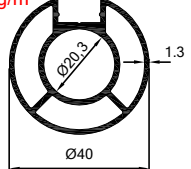
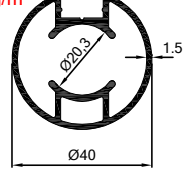
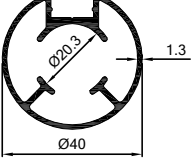
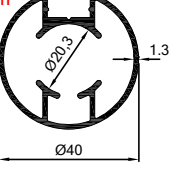
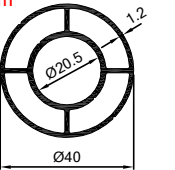
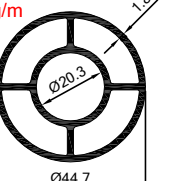
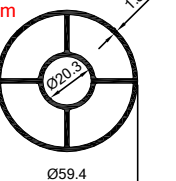
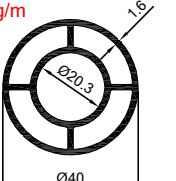
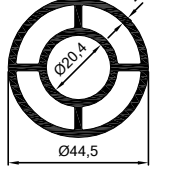
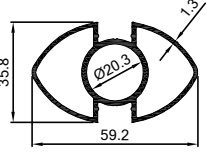
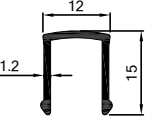
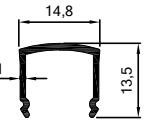
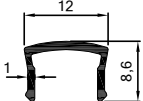
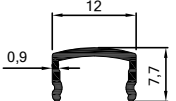
3407 0.387 kg/m 	3427 0.334 kg/m 	2330 0.242 kg/m 	3440 0.600 kg/m 
3358 0.439 kg/m 	3441 0.379 kg/m 	3458 0.350 kg/m 	3359 0.376 kg/m 
218 0.335 kg/m 	1255 0.327 kg/m 	1254 0.451 kg/m 	3404 0.411 kg/m 
3386 0.267 kg/m 	3446 0.710 kg/m 	3477 0.237 kg/m 	3357 0.242 kg/m 
3432 0.336 kg/m 	3364 0.234 kg/m 	219 0.295 kg/m 	3437 0.328 kg/m 
2211 0.321 kg/m 	3414 0.319 kg/m 	5997 0.399 kg/m 	3433 0.481 kg/m 
3484 0.409 kg/m 	4080 0.323 kg/m 	3418 0.747 kg/m 	6330 0.446 kg/m 
4276 0.698 kg/m 	3385 0.455 kg/m 	3424 0.482 kg/m 	3456 0.453 kg/m 

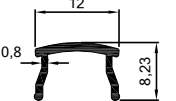
3435 0.680 kg/m 	3457 0.662 kg/m 	3423 0.634 kg/m 	3415 0.514 kg/m 
3390 0.683 kg/m 	3490 0.450 kg/m 	3486 0.661 kg/m 	6407 0.584 kg/m 
3491 0.654 kg/m 	3391 0.730 kg/m 	3403 0.863 kg/m 	1253 0.754 kg/m 
3422 0.914 kg/m 	3474 0.901 kg/m 	3476 0.917 kg/m 	3417 1.002 kg/m 
4277 0.889 kg/m 	3392 1.177 kg/m 	3429 1.318 kg/m 	3362 1.227 kg/m 
3459 1.464 kg/m 	3482 2.909 kg/m 	3473 0.947 kg/m 	3419 0.846 kg/m 
3420 0.845 kg/m 	5996 0.995 kg/m 	3453 1.111 kg/m 	3416 1.000 kg/m 
3445 0.634 kg/m 	3442 0.209 kg/m 	3410 0.994 kg/m 	3368 1.766 kg/m 

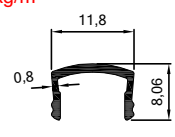
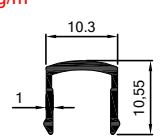
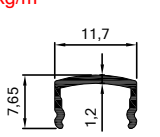
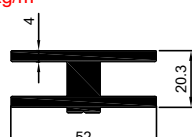
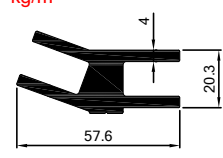
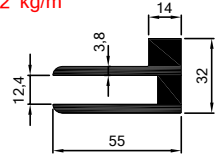
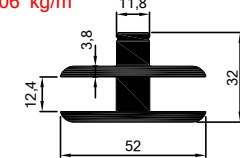
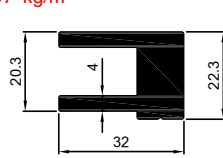
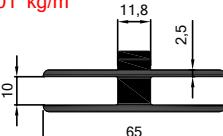
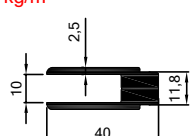
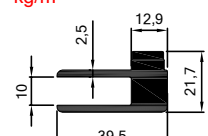
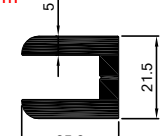
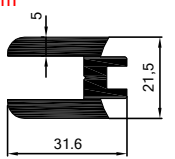
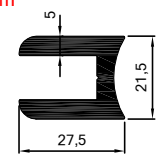
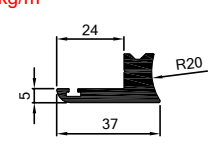
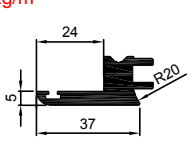
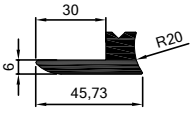
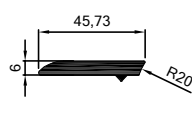
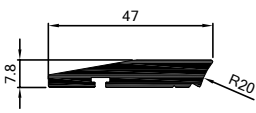
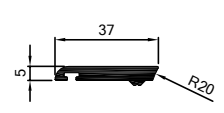
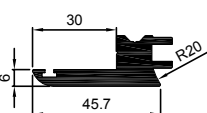
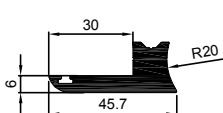
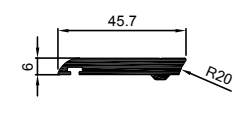

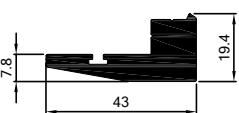
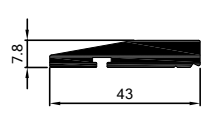
<p>3408 0.379 kg/m</p> 	<p>3447 0.141 kg/m</p> 	<p>3443 0.098 kg/m</p> 	<p>3363 0.863 kg/m</p> 
<p>3381 0.971 kg/m</p> 	<p>3372 1.169 kg/m</p> 	<p>3382 0.791 kg/m</p> 	<p>3369 0.518 kg/m</p> 
<p>3464 0.672 kg/m</p> 	<p>3370 0.986 kg/m</p> 	<p>3462 1.015 kg/m</p> 	<p>3463 0.688 kg/m</p> 
<p>3405 1.584 kg/m</p> 	<p>3413 0.182 kg/m</p> 		

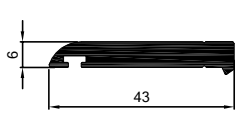
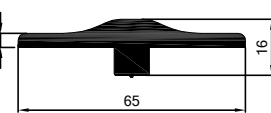
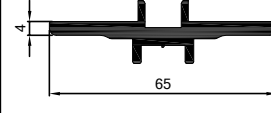
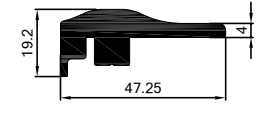
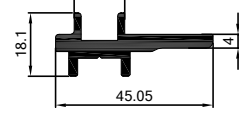
1010 1.143 kg/m 	1006 0.855 kg/m 	1599 0.762 kg/m 	1186 0.692 kg/m 
1232 1.098 kg/m 	973 1.529 kg/m 	3089 0.877 kg/m 	1680 0.880 kg/m 
2841 1.002 kg/m 	5727 0.833 kg/m 	1565 0.911 kg/m 	2842 0.822 kg/m 
3090 0.714 kg/m 	2879 0.755 kg/m 	8271 0.682 kg/m 	2993 1.017 kg/m 
2246 0.855 kg/m 	3024 0.788 kg/m 	1592 0.679 kg/m 	2245 0.673 kg/m 
4085 0.769 kg/m 	567 1.169 kg/m 	566 1.537 kg/m 	1099 0.956 kg/m 
1588 1.451 kg/m 	4957 0.878 kg/m 	824 0.130 kg/m 	974 0.113 kg/m 
1233 0.074 kg/m 	1022 0.073 kg/m 	1249 0.073 kg/m 	2843 0.073 kg/m 

2826 0.072 kg/m 	1574 0.081 kg/m 	2999 0.068 kg/m 	535 1.590 kg/m 
539 1.737 kg/m 	1185 1.912 kg/m 	1260 1.806 kg/m 	536 1.157 kg/m 
1596 1.401 kg/m 	1594 0.837 kg/m 	1595 1.087 kg/m 	4706 0.814 kg/m 
1009 0.926 kg/m 	1029 0.840 kg/m 	1534 0.764 kg/m 	1540 0.872 kg/m 
1227 1.065 kg/m 	1228 0.700 kg/m 	1984 0.774 kg/m 	1535 0.463 kg/m 
2839 1.143 kg/m 	2882 1.038 kg/m 	2840 0.687 kg/m 	1985 1.141 kg/m 
1987 1.099 kg/m 	1986 0.729 kg/m 	5734 1.050 kg/m 	5735 0.644 kg/m 
3128 1.139 kg/m 	3129 0.957 kg/m 	3130 1.098 kg/m 	3131 0.732 kg/m 

<p>1259 1.417 kg/m</p>	<p>822 1.862 kg/m</p>	<p>923 2.471 kg/m</p>	<p>490 3.283 kg/m</p>
<p>5365 0.764 kg/m</p>	<p>4891 1.054 kg/m</p>	<p>4892 1.196 kg/m</p>	<p>2825 0.598 kg/m</p>
<p>1570 0.467 kg/m</p>	<p>823 1.274 kg/m</p>	<p>4723 1.026 kg/m</p>	<p>5697 1.270 kg/m</p>
<p>3809 1.050 kg/m</p>	<p>2674 1.376 kg/m</p>	<p>636 1.812 kg/m</p>	<p>1187 1.000 kg/m</p>
<p>2752 1.554 kg/m</p>	<p>1208 1.049 kg/m</p>	<p>3114 0.692 kg/m</p>	<p>3115 0.607 kg/m</p>
<p>962 1.269 kg/m</p>	<p>4727 0.977 kg/m</p>	<p>3075 1.183 kg/m</p>	<p>2060 1.780 kg/m</p>
<p>1576 0.160 kg/m</p>	<p>2058 1.579 kg/m</p>	<p>1021 1.084 kg/m</p>	<p>1030 0.609 kg/m</p>
<p>4061 0.714 kg/m</p>	<p>1026 0.213 kg/m</p>	<p>2824 0.307 kg/m</p>	<p>4342 4.338 kg/m</p>

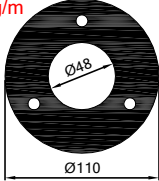
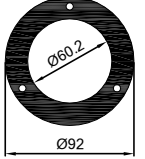
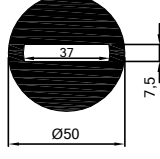
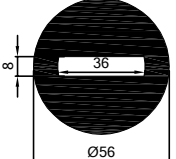
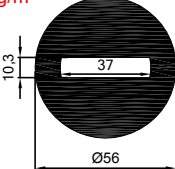
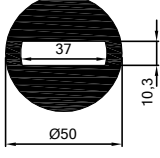
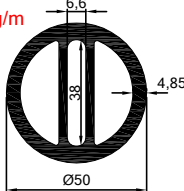
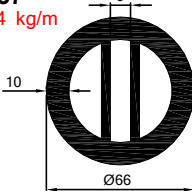
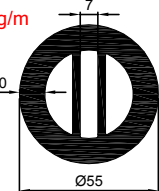
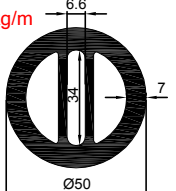
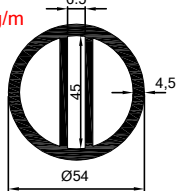
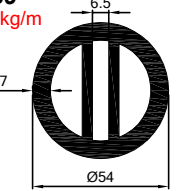
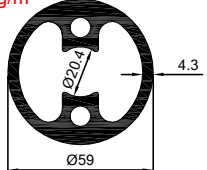
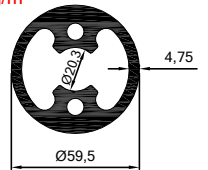
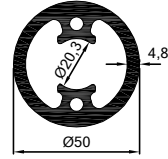
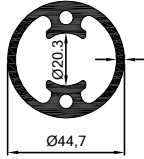
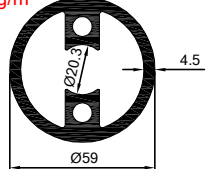
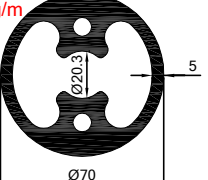
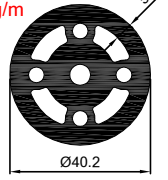
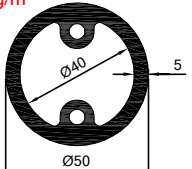
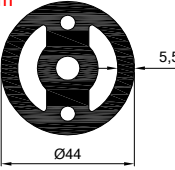
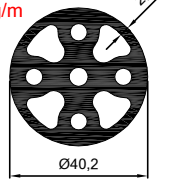
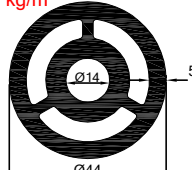
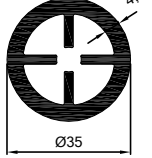
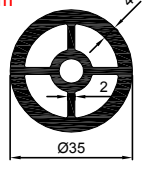

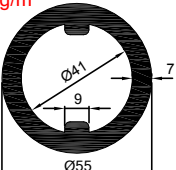
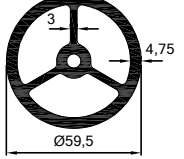
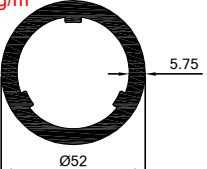
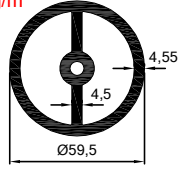
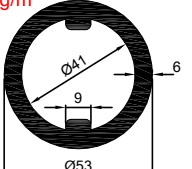
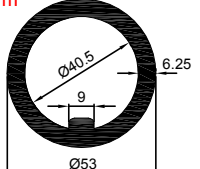
3754 0.534 kg/m 	5942 1.095 kg/m 	5940 4.274 kg/m 	5941 1.574 kg/m
5721 2.828 kg/m 	6805 2.922 kg/m 	6479 3.589 kg/m 	2655 5.666 kg/m
6478 4.887 kg/m 	4339 7.775 kg/m 	963 2.533 kg/m 	8096 1.982 kg/m
594 2.926 kg/m 	2951 1.786 kg/m 	538 7.410 kg/m 	5760 0.848 kg/m
5761 1.353 kg/m 	5759 1.047 kg/m 	5758 5.185 kg/m 	5397 1.047 kg/m
3797 0.705 kg/m 	3799 1.425 kg/m 	3798 0.972 kg/m 	1590 1.563 kg/m
2953 2.281 kg/m 	2952 2.710 kg/m 	969 4.173 kg/m 	970 6.068 kg/m
971 7.421 kg/m 	2832 7.788 kg/m 	972 8.775 kg/m 	1408 7.987 kg/m

8110 20.389 kg/m 	1231 10.130 kg/m 	2547 4.574 kg/m 	493 5.901 kg/m 
4040 5.655 kg/m 	1037 4.303 kg/m 	2714 2.564 kg/m 	537 5.724 kg/m 
496 4.377 kg/m 	494 3.185 kg/m 	2647 2.844 kg/m 	2939 3.636 kg/m 
4724 3.247 kg/m 	941 3.767 kg/m 	1591 2.485 kg/m 	975 1.642 kg/m 
4795 2.986 kg/m 	2715 5.155 kg/m 	4069 2.556 kg/m 	1393 2.418 kg/m 
2651 3.985 kg/m 	2680 2.265 kg/m 	2638 2.365 kg/m 	2549 1.428 kg/m 
2850 1.422 kg/m 	1394 1.185 kg/m 	1013 3.063 kg/m 	1587 3.074 kg/m 
4829 2.361 kg/m 	1589 2.971 kg/m 	2699 2.603 kg/m 	2833 2.582 kg/m 

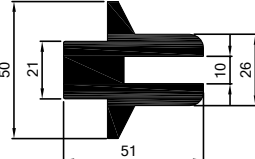
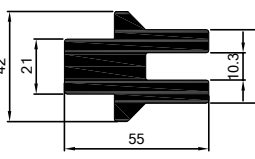
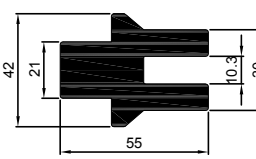
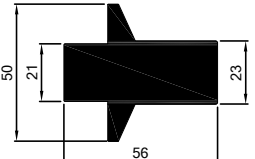
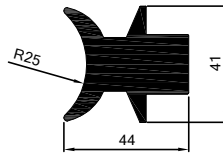
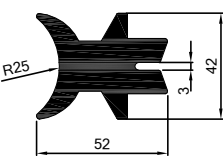
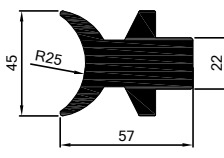
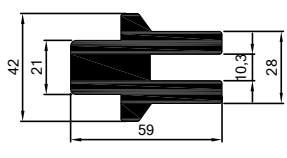
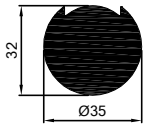
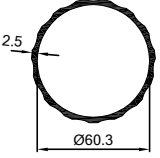
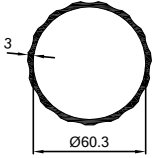
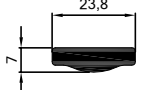
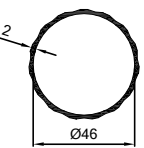
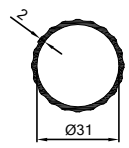
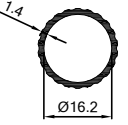
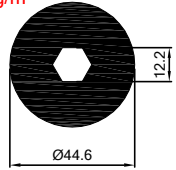
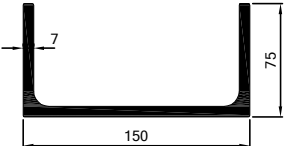
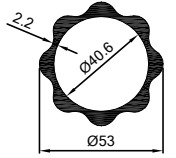
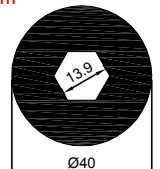
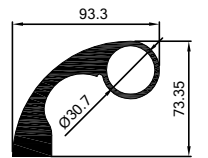
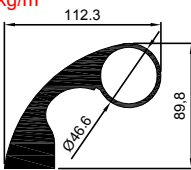
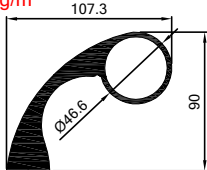
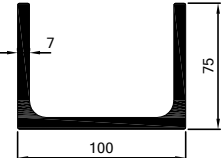
3761 1.859 kg/m 	4028 1.975 kg/m 	495 2.343 kg/m 	1597 2.189 kg/m
1598 1.957 kg/m 	2530 0.855 kg/m 	2712 1.023 kg/m 	2981 0.786 kg/m
2729 1.093 kg/m 	1203 0.876 kg/m 	2069 1.209 kg/m 	5902 0.883 kg/m
3899 0.733 kg/m 	1008 1.223 kg/m 	5757 0.754 kg/m 	2980 2.643 kg/m
4340 2.333 kg/m 	499 3.534 kg/m 	2191 4.040 kg/m 	4726 2.281 kg/m
2881 3.102 kg/m 	2844 2.740 kg/m 	2728 2.755 kg/m 	2567 2.996 kg/m
2656 3.005 kg/m 	2686 3.667 kg/m 	2057 3.514 kg/m 	3760 2.539 kg/m
5959 2.609 kg/m 	2686 3.667 kg/m 	6462 2.232 kg/m 	4100 3.272 kg/m

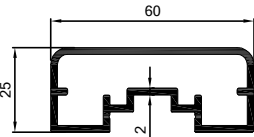
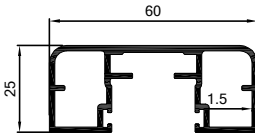
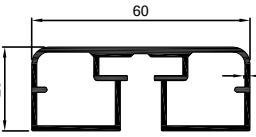
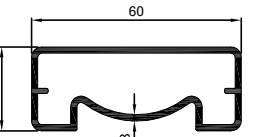
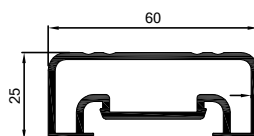
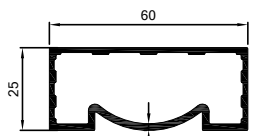
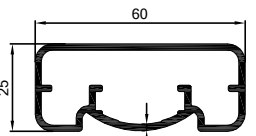
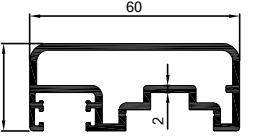
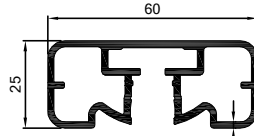
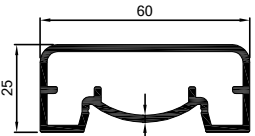
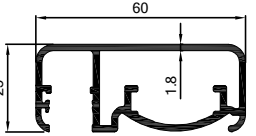
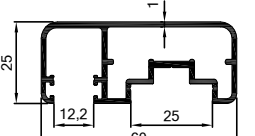
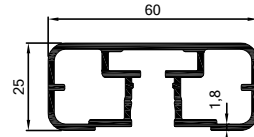
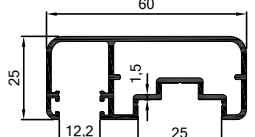
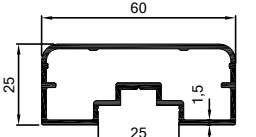
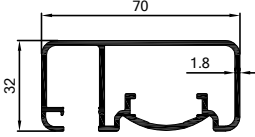
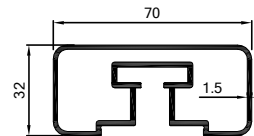
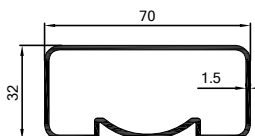
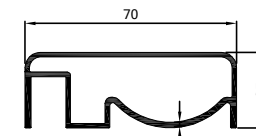
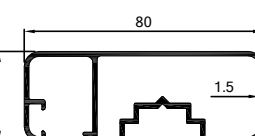
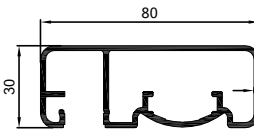
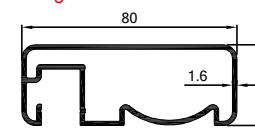
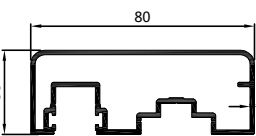
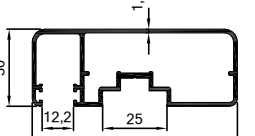
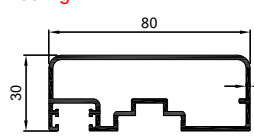
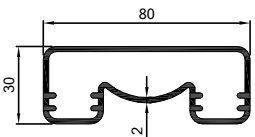
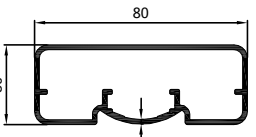
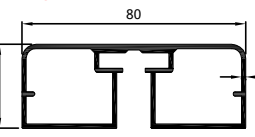
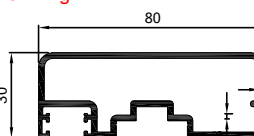
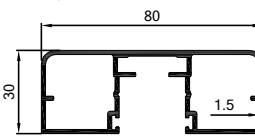
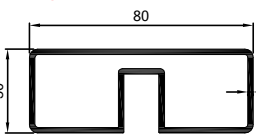
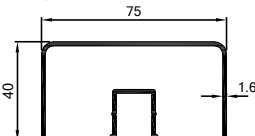

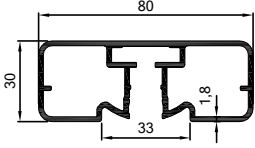
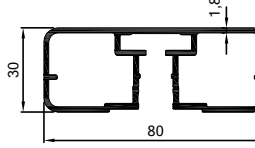
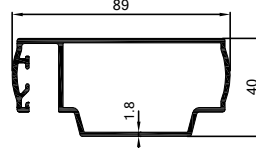
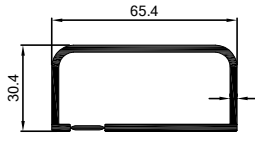
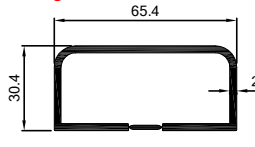
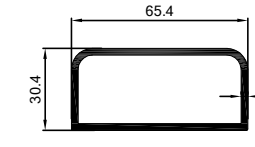
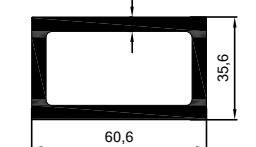
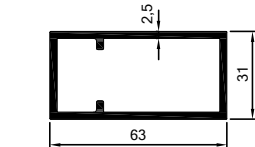
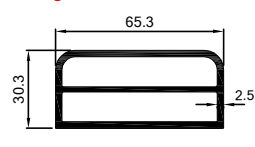
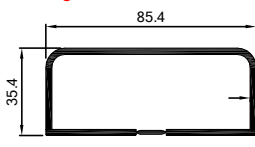
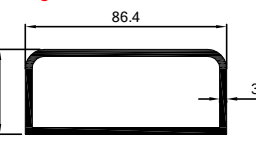
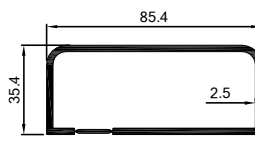
<p>6685 3.013 kg/m</p> 	<p>3862 3.462 kg/m</p> 	<p>2065 3.610 kg/m</p> 	<p>6684 3.911 kg/m</p> 
<p>3759 2.616 kg/m</p> 	<p>2689 3.211 kg/m</p> 	<p>6168 3.382 kg/m</p> 	<p>6167 3.677 kg/m</p> 
<p>2654 2.432 kg/m</p> 	<p>6023 1.266 kg/m</p> 	<p>1036 1.377 kg/m</p> 	<p>1223 0.375 kg/m</p> 
<p>6492 0.675 kg/m</p> 	<p>6493 0.482 kg/m</p> 	<p>6494 0.190 kg/m</p> 	<p>5744 3.885 kg/m</p> 
<p>2831 5.538 kg/m</p> 	<p>5370 1.665 kg/m</p> 	<p>3082 2.955 kg/m</p> 	<p>1988 4.486 kg/m</p> 
<p>2784 6.753 kg/m</p> 	<p>385 5.067 kg/m</p> 	<p>2830 4.590 kg/m</p> 	

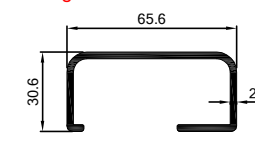
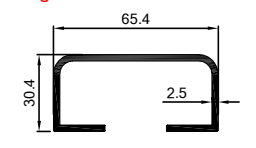
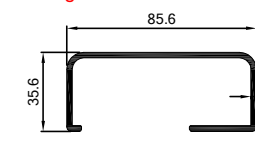
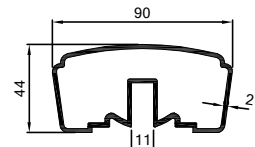
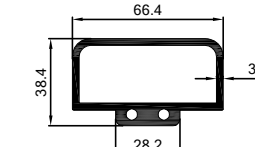
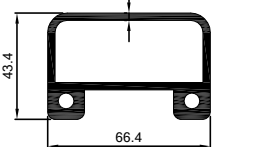
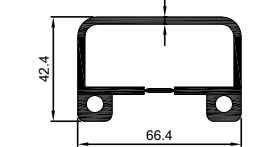
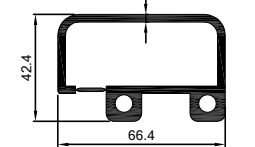
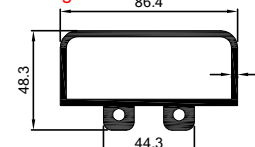
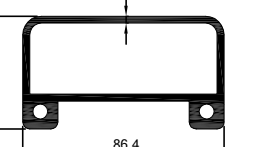
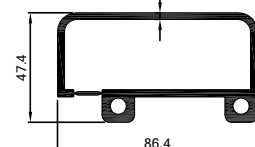
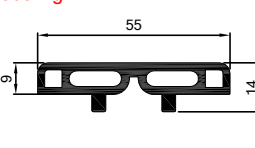
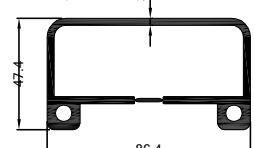
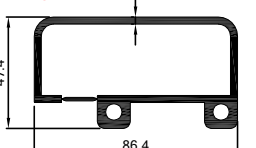
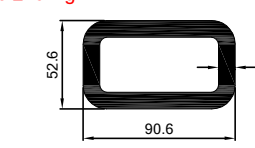
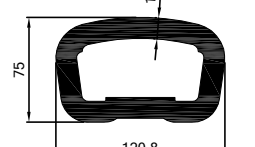
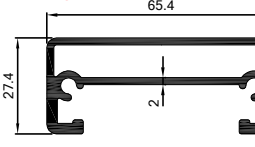
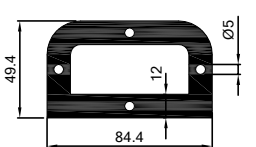
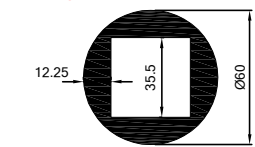
4107 1.041 kg/m 	6610 0.887 kg/m 	4893 0.955 kg/m 	5376 0.873 kg/m 
4122 1.037 kg/m 	5764 0.857 kg/m 	3627 0.938 kg/m 	4096 1.072 kg/m 
3628 1.108 kg/m 	4162 1.013 kg/m 	3626 0.978 kg/m 	6813 0.854 kg/m 
6617 1.071 kg/m 	6974 0.816 kg/m 	6816 0.792 kg/m 	7423 1.176 kg/m 
5983 1.182 kg/m 	3133 0.860 kg/m 	5364 0.925 kg/m 	7112 1.069 kg/m 
3629 1.271 kg/m 	1000 1.149 kg/m 	5989 1.217 kg/m 	6814 1.076 kg/m 
5677 1.166 kg/m 	1399 1.374 kg/m 	3631 1.182 kg/m 	4894 1.211 kg/m 
4761 1.344 kg/m 	6611 1.132 kg/m 	5631 1.355 kg/m 	6454 1.127 kg/m 

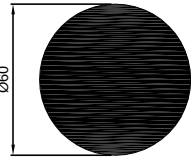
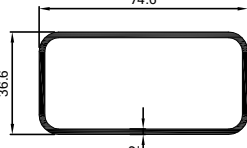
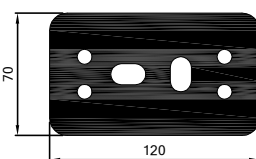
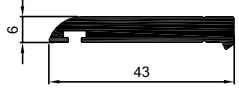
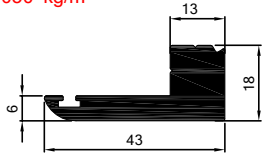
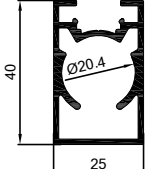
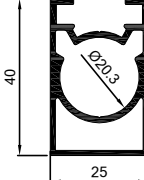
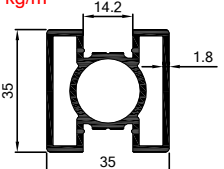
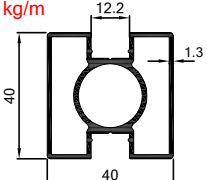
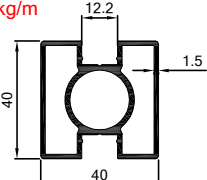
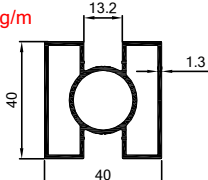
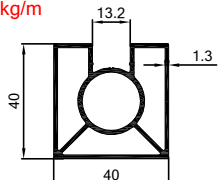
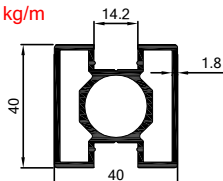
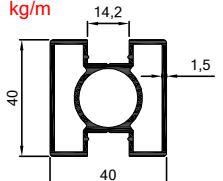
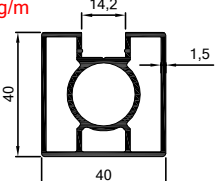
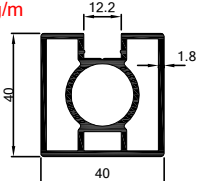
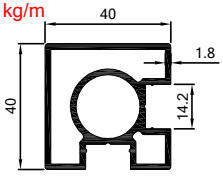
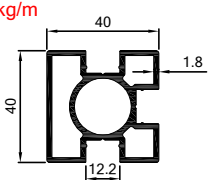
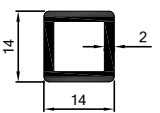
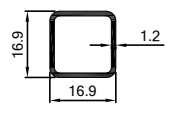
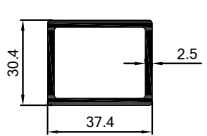
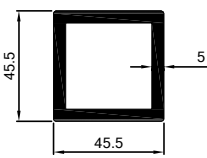
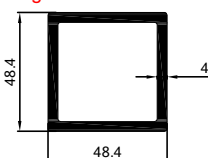
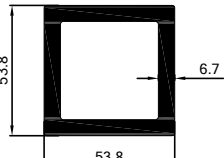
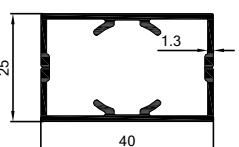
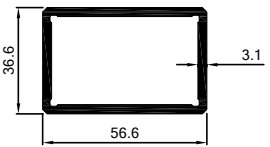
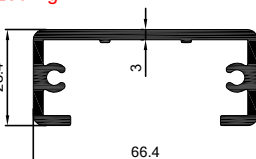
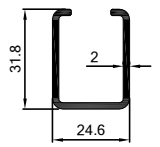
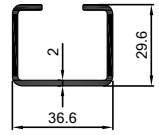
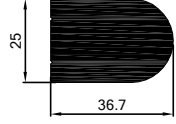
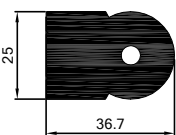
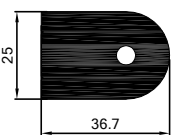

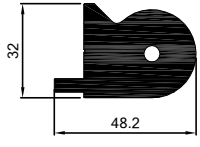
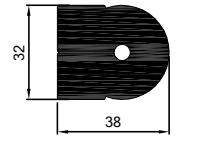
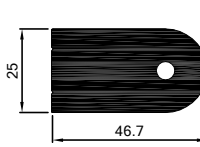
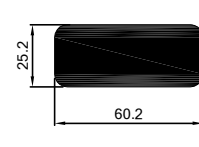
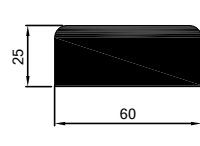
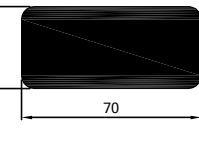
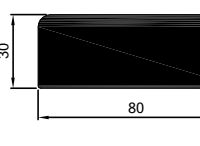
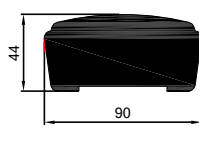
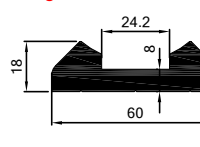
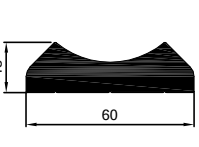
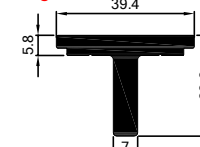
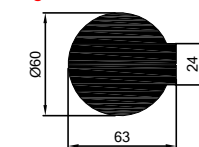
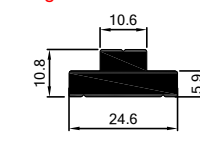
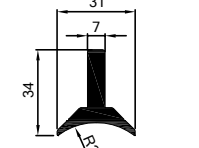
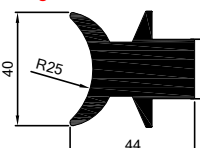
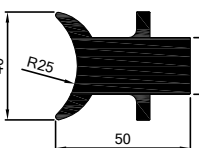
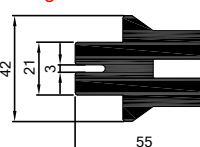
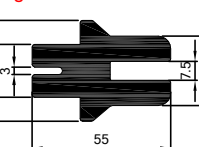
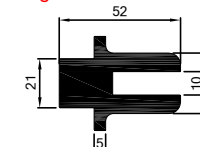
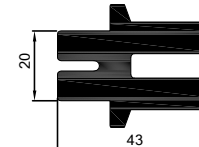
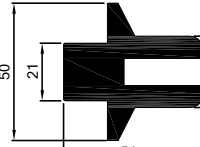
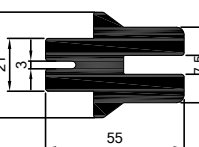
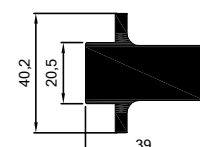
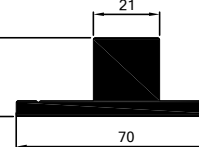
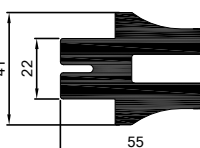
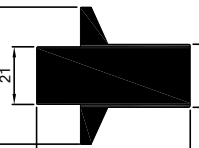
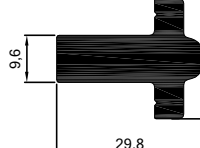
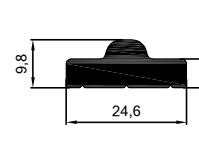
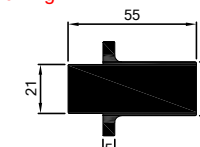
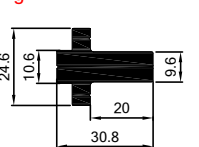
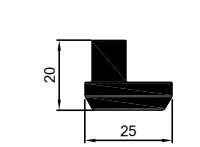
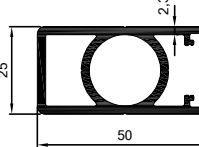

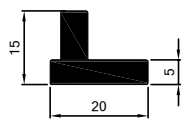
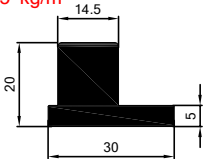
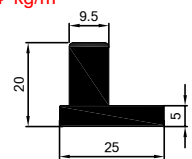
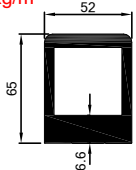
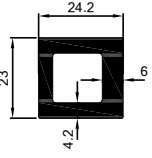
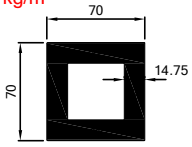
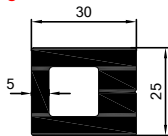
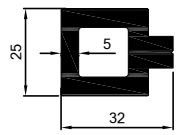
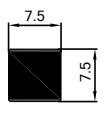
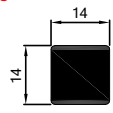
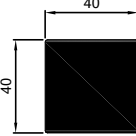
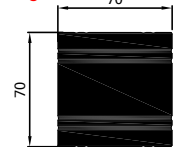
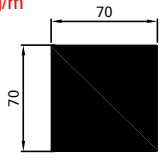
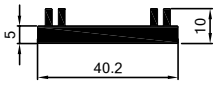
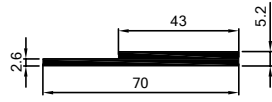
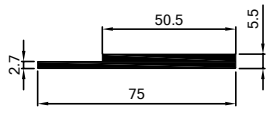
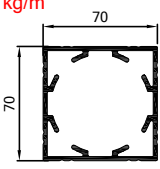
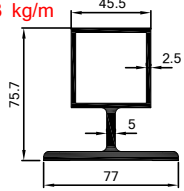
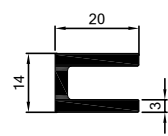
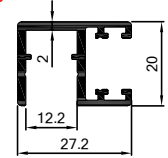
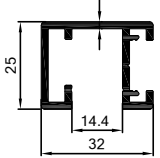
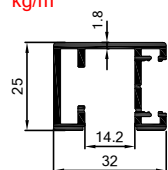
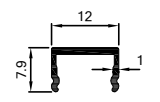
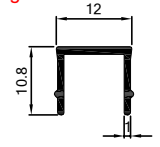
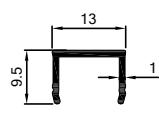
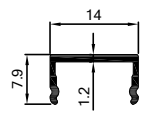
3630 1.397 kg/m 	6618 1.360 kg/m 	6635 1.321 kg/m 	6771 1.154 kg/m 
6267 1.154 kg/m 	4111 1.487 kg/m 	6683 2.345 kg/m 	7634 1.261 kg/m 
5636 1.519 kg/m 	6268 1.492 kg/m 	4760 1.852 kg/m 	6772 1.484 kg/m 
6615 1.459 kg/m 	3624 0.949 kg/m 	6614 1.027 kg/m 	3625 1.201 kg/m 
3900 1.639 kg/m 	4098 1.865 kg/m 	5325 2.230 kg/m 	6269 1.997 kg/m 
6271 1.995 kg/m 	4762 2.638 kg/m 	5324 2.634 kg/m 	6272 2.402 kg/m 
4109 0.905 kg/m 	6270 2.404 kg/m 	6274 2.390 kg/m 	3134 6.279 kg/m 
3902 11.975 kg/m 	4334 1.241 kg/m 	4110 6.616 kg/m 	4338 4.247 kg/m 

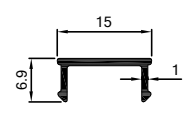
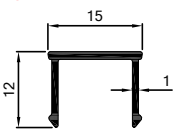
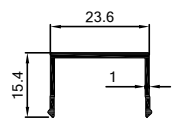
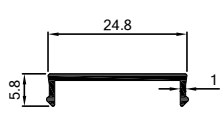
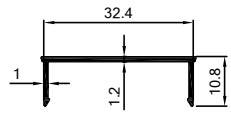

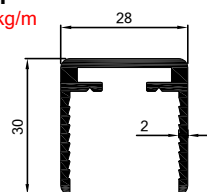
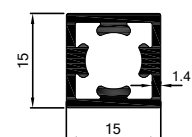
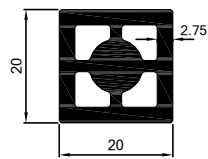
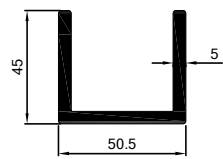
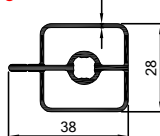
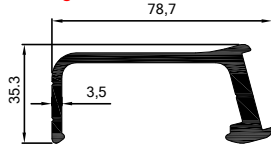
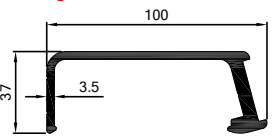
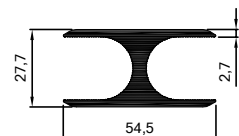
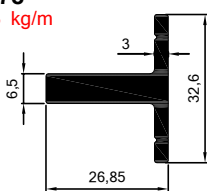
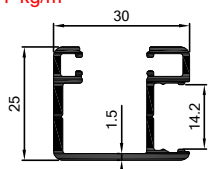
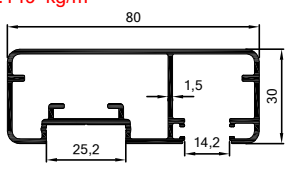
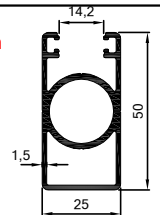
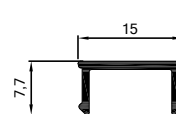
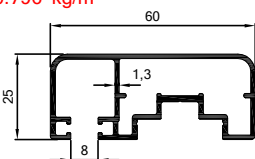
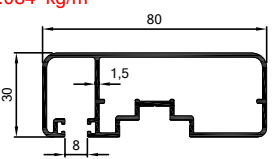
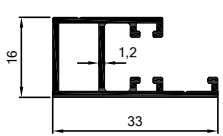
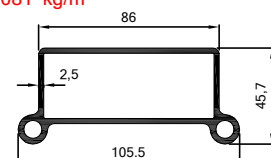
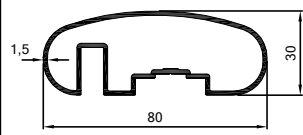
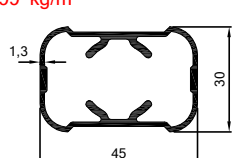
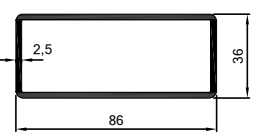
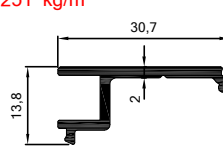
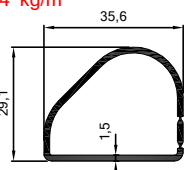
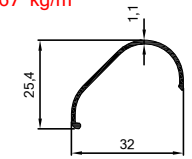
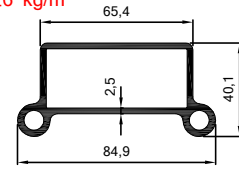
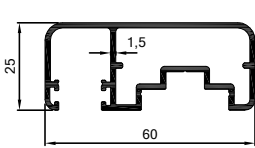
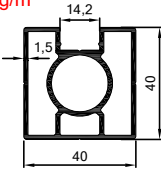
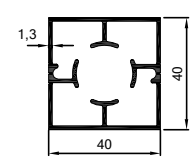
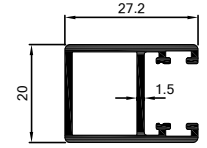
1023 7.662 kg/m 	4333 1.106 kg/m 	4895 20.783 kg/m 	5735 0.644 kg/m 
5734 1.050 kg/m 	6767 0.735 kg/m 	7114 0.704 kg/m 	4335 0.996 kg/m 
5763 0.911 kg/m 	5434 1.020 kg/m 	7113 0.869 kg/m 	7115 0.945 kg/m 
1410 1.188 kg/m 	5679 1.014 kg/m 	5678 1.046 kg/m 	590 1.209 kg/m 
4699 1.156 kg/m 	591 1.183 kg/m 	1409 0.258 kg/m 	5637 0.194 kg/m 
4106 0.851 kg/m 	4336 2.193 kg/m 	4123 1.925 kg/m 	4103 3.421 kg/m 
7350 0.557 kg/m 	4898 1.427 kg/m 	5984 1.236 kg/m 	6612 0.478 kg/m 
6613 0.572 kg/m 	4160 2.303 kg/m 	4119 2.216 kg/m 	4128 2.239 kg/m 

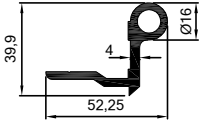
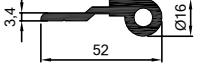
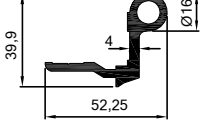
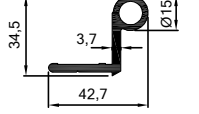
5721 2.828 kg/m 	6805 2.922 kg/m 	4132 2.916 kg/m 	7101 4.051 kg/m 
4116 4.036 kg/m 	4341 6.012 kg/m 	5639 6.474 kg/m 	3901 9.344 kg/m 
4121 1.884 kg/m 	4129 2.128 kg/m 	4125 1.020 kg/m 	4120 7.910 kg/m 
4108 0.532 kg/m 	2530 0.855 kg/m 	3759 2.616 kg/m 	4767 3.044 kg/m 
2686 3.667 kg/m 	4159 3.438 kg/m 	4764 2.849 kg/m 	4340 2.333 kg/m 
6685 3.013 kg/m 	2686 3.667 kg/m 	7349 2.263 kg/m 	7389 2.084 kg/m 
964 3.374 kg/m 	6684 3.911 kg/m 	6812 0.991 kg/m 	6811 0.469 kg/m 
4763 3.664 kg/m 	4114 1.053 kg/m 	4161 0.835 kg/m 	6679 1.120 kg/m 

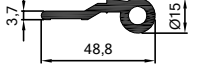
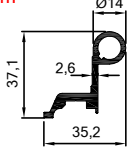
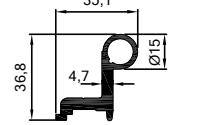
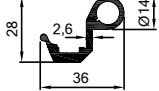
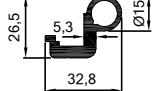
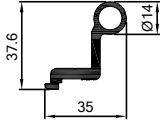
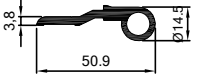
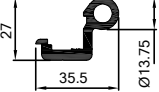
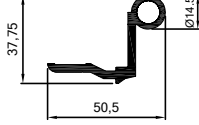
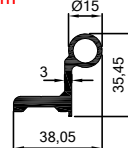
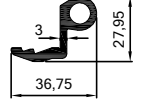
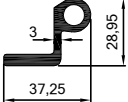
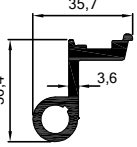
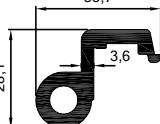
4897 0.420 kg/m 	5950 0.995 kg/m 	5949 0.724 kg/m 	4896 4.706 kg/m 
4337 0.932 kg/m 	4954 8.603 kg/m 	4115 1.456 kg/m 	4127 1.288 kg/m 
5791 0.153 kg/m 	4101 0.529 kg/m 	4102 4.334 kg/m 	4118 13.228 kg/m  <p>Desenli</p>
7261 13.277 kg/m 	4766 0.653 kg/m 	5638 0.796 kg/m 	5948 0.932 kg/m 
4117 2.439 kg/m 	4953 2.573 kg/m 	4104 0.391 kg/m 	4097 0.420 kg/m 
4105 0.588 kg/m 	5990 0.567 kg/m 	592 0.073 kg/m 	4099 0.094 kg/m 
7301 0.087 kg/m 	1411 0.080 kg/m 	4112 0.078 kg/m 	5992 0.080 kg/m 
5991 0.108 kg/m 	6616 0.155 kg/m 	4113 0.108 kg/m 	4126 0.160 kg/m 

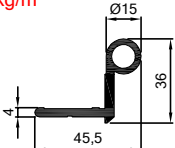
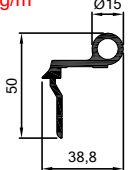
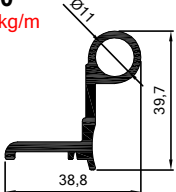
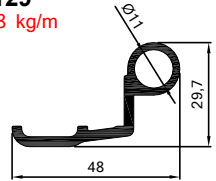
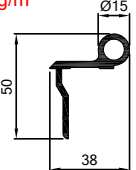
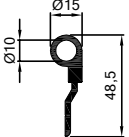
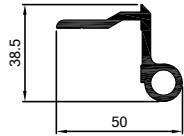
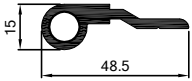
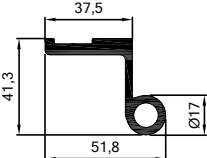
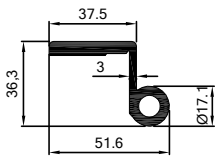
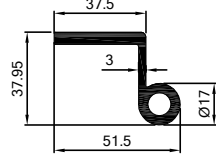
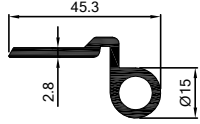

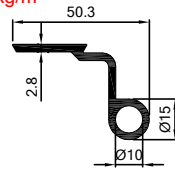
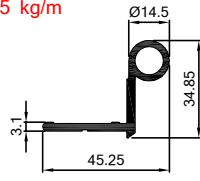
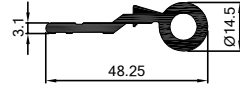
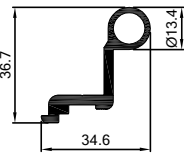
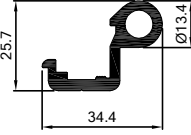
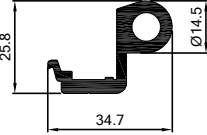
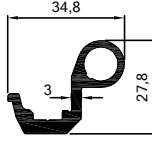
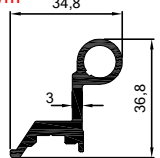
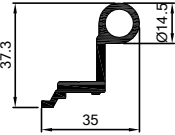
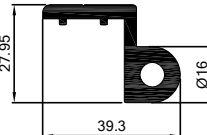
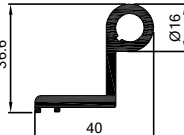
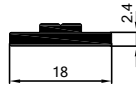
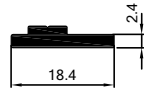
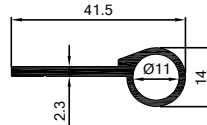
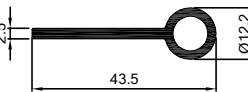
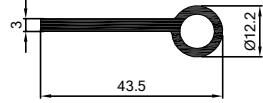
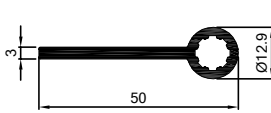
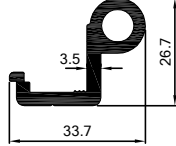
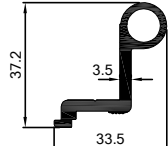
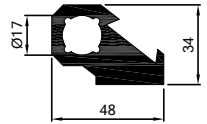
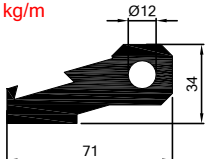
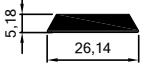
<p>7311 0.528 kg/m</p> 	<p>5765 0.302 kg/m</p> 	<p>4765 0.763 kg/m</p> 	<p>6273 1.765 kg/m</p> 
<p>6680 0.575 kg/m</p> 	<p>6681 1.566 kg/m</p> 	<p>6682 1.873 kg/m</p> 	<p>6985 1.315 kg/m</p> 
<p>6278 0.683 kg/m</p> 	<p>7251 0.454 kg/m</p> 	<p>7242 1.149 kg/m</p> 	<p>7253 0.872 kg/m</p> 
<p>7241 0.084 kg/m</p> 	<p>7850 0.796 kg/m</p> 	<p>7851 1.084 kg/m</p> 	<p>7852 0.325 kg/m</p> 
<p>7854 2.081 kg/m</p> 	<p>7855 0.960 kg/m</p> 	<p>7856 0.699 kg/m</p> 	<p>7853 1.565 kg/m</p> 
<p>7858 0.251 kg/m</p> 	<p>7859 0.424 kg/m</p> 	<p>7857 0.167 kg/m</p> 	<p>6169 1.726 kg/m</p> 
<p>6974 0.816 kg/m</p> 	<p>6099 1.046 kg/m</p> 	<p>7351 0.818 kg/m</p> 	<p>8338 0.403 kg/m</p> 

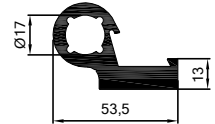
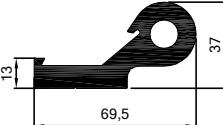
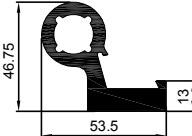
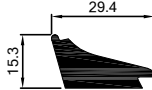
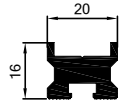
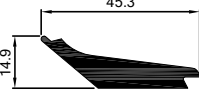
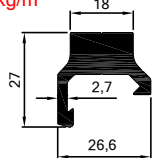
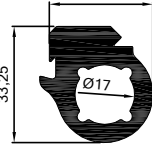
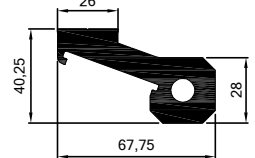

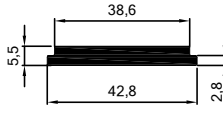
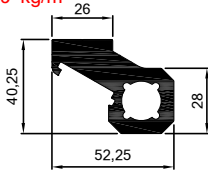
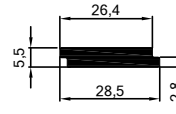
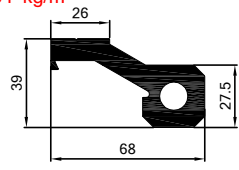
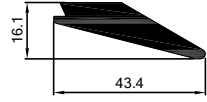
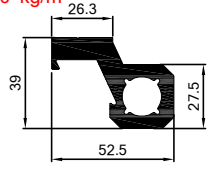
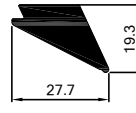
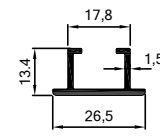
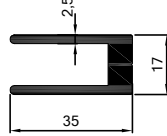
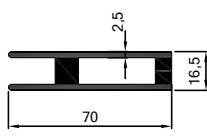
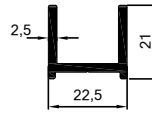
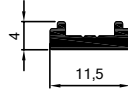
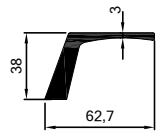
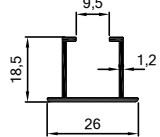
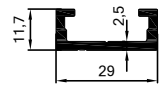
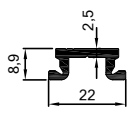
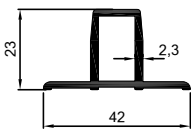
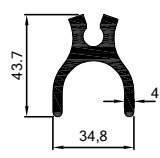
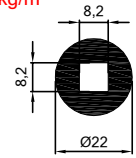
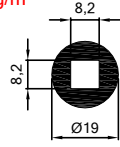
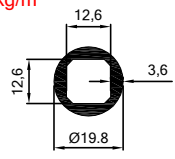
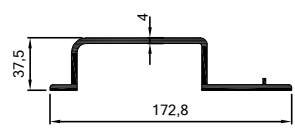
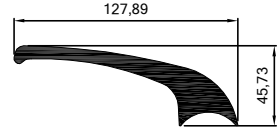
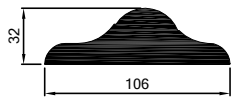
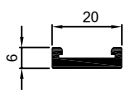
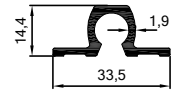
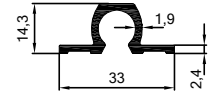
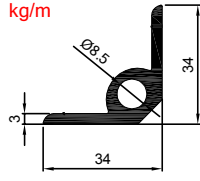
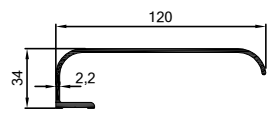
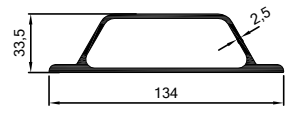
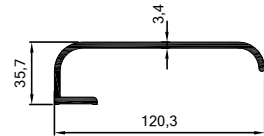
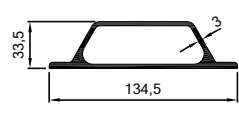
445 0.983 kg/m 	446 0.840 kg/m 	447 1.037 kg/m 	449 0.731 kg/m 
448 0.764 kg/m 	450 0.720 kg/m 	2144 0.609 kg/m 	2152 0.799 kg/m 
2145 0.581 kg/m 	2153 0.666 kg/m 	2156 0.698 kg/m 	2267 0.651 kg/m 
2157 0.706 kg/m 	2269 0.824 kg/m 	1610 0.730 kg/m 	1611 0.667 kg/m 
1612 0.745 kg/m 	1682 0.811 kg/m 	1683 0.815 kg/m 	440 0.726 kg/m 
442 0.798 kg/m 	486 0.803 kg/m 	6130 0.651 kg/m 	6129 0.628 kg/m 
487 0.764 kg/m 	488 0.622 kg/m 	392 0.843 kg/m 	393 0.658 kg/m 
1967 1.171 kg/m 	1968 1.162 kg/m 	1969 1.100 kg/m 	394 0.615 kg/m 

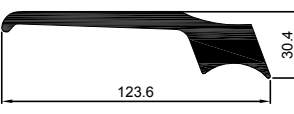
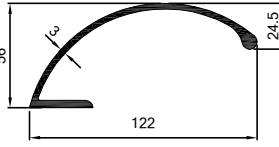
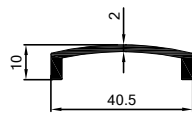
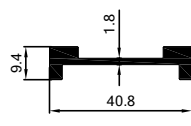
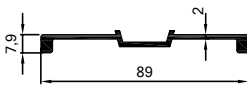
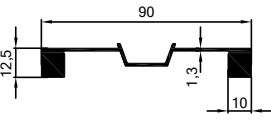
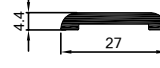
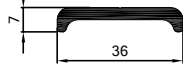
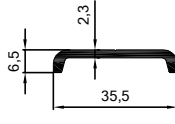
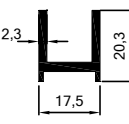
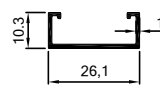
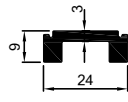
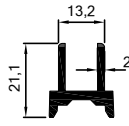
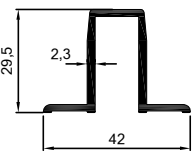
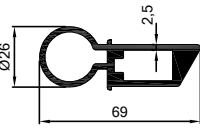
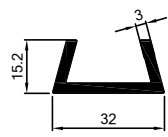
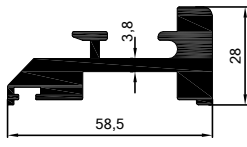
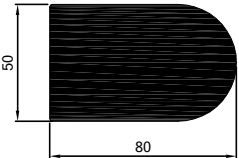
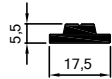
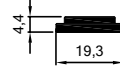
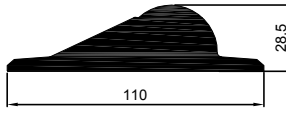
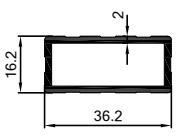
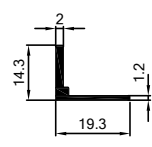
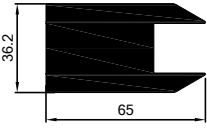
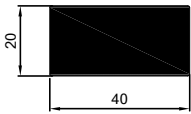

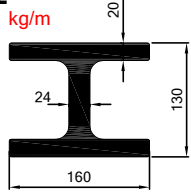
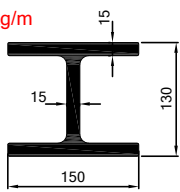
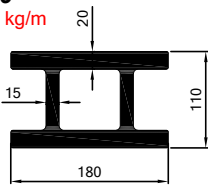
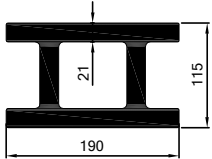
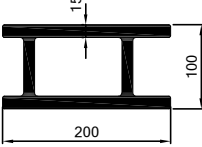
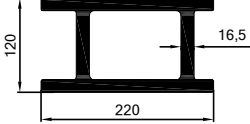
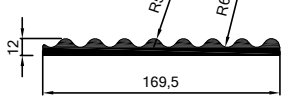
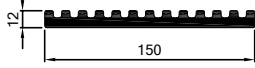
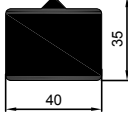
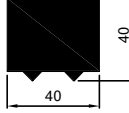
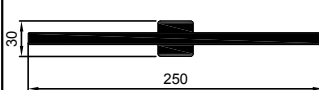
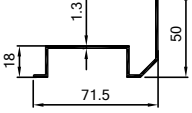
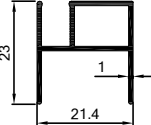

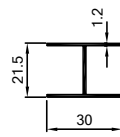
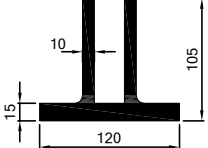
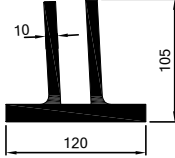
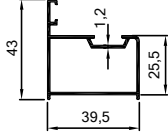
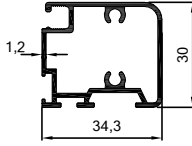
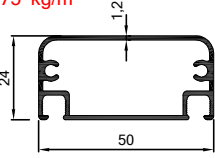
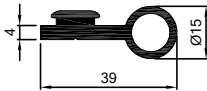
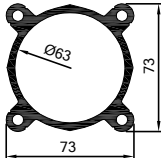
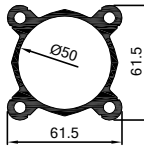
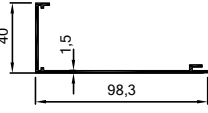
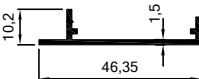
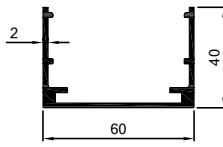
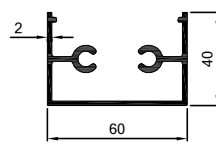
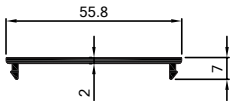
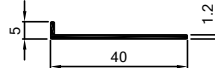
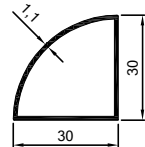
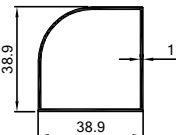
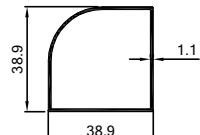
<p>395 0.704 kg/m</p> 	<p>5709 0.635 kg/m</p> 	<p>5710 0.604 kg/m</p> 	<p>4064 0.586 kg/m</p> 
<p>4065 0.602 kg/m</p> 	<p>4047 0.688 kg/m</p> 	<p>667 0.612 kg/m</p> 	<p>668 0.645 kg/m</p> 
<p>4048 0.623 kg/m</p> 	<p>3967 0.896 kg/m</p> 	<p>3966 0.819 kg/m</p> 	<p>3968 0.147 kg/m</p> 
<p>3969 0.148 kg/m</p> 	<p>564 0.354 kg/m</p> 	<p>1921 0.386 kg/m</p> 	<p>1976 0.430 kg/m</p> 
<p>2800 0.488 kg/m</p> 	<p>6827 0.629 kg/m</p> 	<p>6826 0.620 kg/m</p> 	<p>2150 2.202 kg/m</p> 
<p>2151 3.437 kg/m</p> 	<p>2155 0.333 kg/m</p> 	<p>2154 0.422 kg/m</p> 	<p>461 1.923 kg/m</p> 
<p>463 2.701 kg/m</p> 	<p>491 2.119 kg/m</p> 	<p>462 0.638 kg/m</p> 	<p>2140 0.539 kg/m</p> 
<p>464 0.754 kg/m</p> 	<p>2138 0.823 kg/m</p> 	<p>2139 1.438 kg/m</p> 	<p>482 3.143 kg/m</p> 

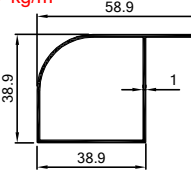
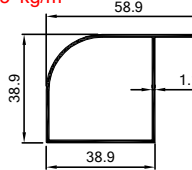
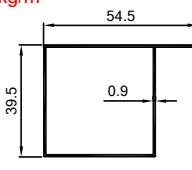
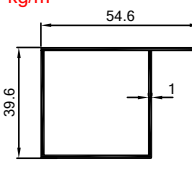
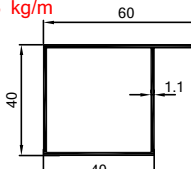
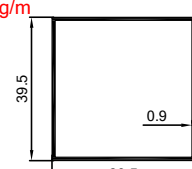
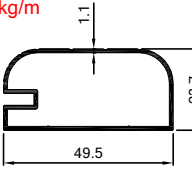
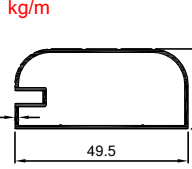
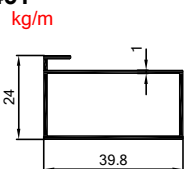
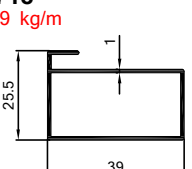
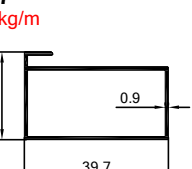
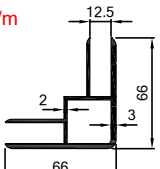
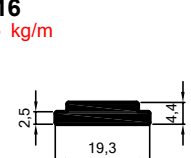
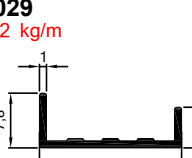
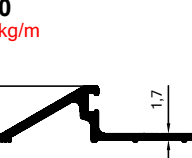
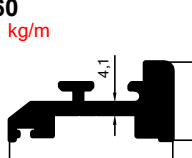
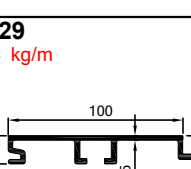
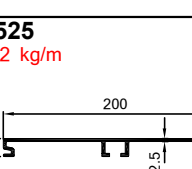
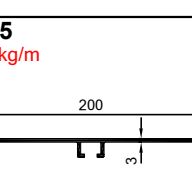
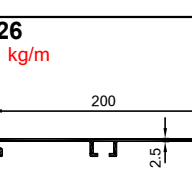
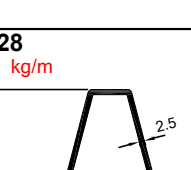
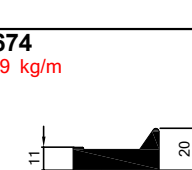
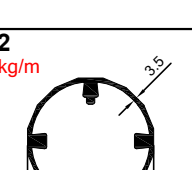
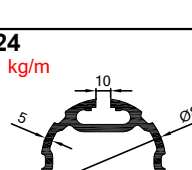
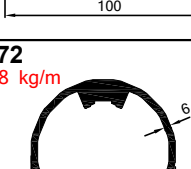
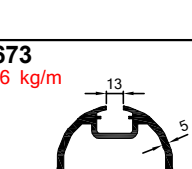
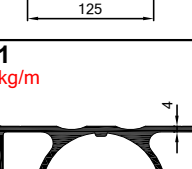
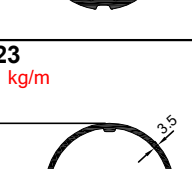
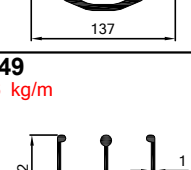
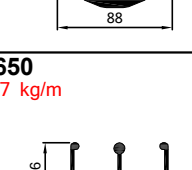
483 0.604 kg/m 	484 2.469 kg/m 	485 0.392 kg/m 	4043 2.764 kg/m 
4044 0.840 kg/m 	4045 2.130 kg/m 	4046 0.714 kg/m 	1604 0.243 kg/m 
1054 0.700 kg/m 	1055 1.485 kg/m 	1056 0.399 kg/m 	1613 0.080 kg/m 
902 1.472 kg/m 	348 0.214 kg/m 	1225 0.306 kg/m 	1226 0.238 kg/m 
355 0.507 kg/m 	1606 1.315 kg/m 	1608 0.848 kg/m 	2734 0.769 kg/m 
125 0.423 kg/m 	900 2.567 kg/m 	2149 4.030 kg/m 	2148 5.235 kg/m 
2161 0.204 kg/m 	1607 0.345 kg/m 	351 0.335 kg/m 	2995 0.702 kg/m 
347 0.940 kg/m 	352 2.063 kg/m 	1600 1.632 kg/m 	1601 2.509 kg/m 

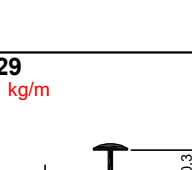
<p>498 3.314 kg/m</p> 	<p>2061 1.662 kg/m</p> 	<p>5673 0.323 kg/m</p> 	<p>5674 0.433 kg/m</p> 
<p>1605 0.685 kg/m</p> 	<p>350 0.968 kg/m</p> 	<p>4066 0.229 kg/m</p> 	<p>1602 0.387 kg/m</p> 
<p>346 0.269 kg/m</p> 	<p>436 0.328 kg/m</p> 	<p>2146 0.151 kg/m</p> 	<p>2147 0.349 kg/m</p> 
<p>437 0.354 kg/m</p> 	<p>349 0.538 kg/m</p> 	<p>354 1.430 kg/m</p> 	<p>2585 0.460 kg/m</p> 
<p>2732 1.706 kg/m</p> 	<p>2738 10.112 kg/m</p> 	<p>417 0.192 kg/m</p> 	<p>416 0.205 kg/m</p> 
<p>497 4.455 kg/m</p> 	<p>3906 0.504 kg/m</p> 	<p>5675 0.142 kg/m</p> 	<p>3907 4.982 kg/m</p> 
<p>3904 2.167 kg/m</p> 			

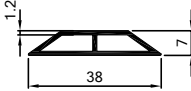
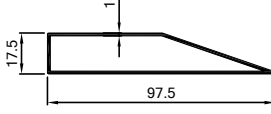
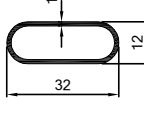
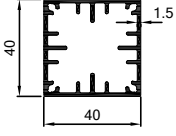
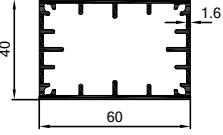
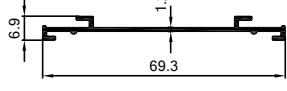
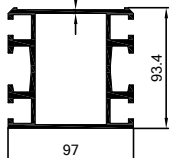
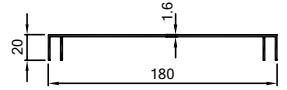
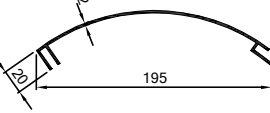
<p>202 23.705 kg/m</p> 	<p>2648 16.474 kg/m</p> 	<p>2709 25.300 kg/m</p> 	<p>2178 29.834 kg/m</p> 
<p>6098 12.248 kg/m</p> 	<p>8059 27.035 kg/m</p> 	<p>318 4.703 kg/m</p> 	<p>207 3.943 kg/m</p> 
<p>1541 3.297 kg/m</p> 	<p>6266 3.651 kg/m</p> 	<p>2970 8.390 kg/m</p> 	<p>1412 0.671 kg/m</p> 
<p>3746 0.234 kg/m</p> 	<p>3138 1.062 kg/m</p> 	<p>4780 0.256 kg/m</p> 	<p>2164 9.813 kg/m</p> 
<p>2165 9.757 kg/m</p> 	<p>2212 0.512 kg/m</p> 	<p>2213 0.559 kg/m</p> 	<p>2214 0.575 kg/m</p> 
<p>2215 0.617 kg/m</p> 	<p>1212 3.512 kg/m</p> 	<p>1213 2.558 kg/m</p> 	<p>950 0.631 kg/m</p> 
<p>951 0.263 kg/m</p> 	<p>2834 0.927 kg/m</p> 	<p>2835 1.180 kg/m</p> 	<p>2836 0.352 kg/m</p> 
<p>6423 0.142 kg/m</p> 	<p>227 0.307 kg/m</p> 	<p>4307 0.388 kg/m</p> 	<p>4041 0.426 kg/m</p> 

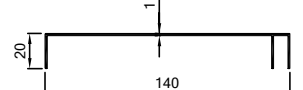
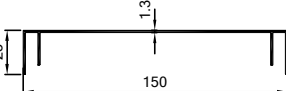
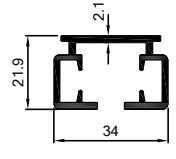
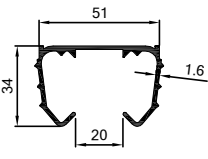
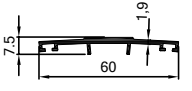
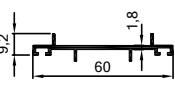
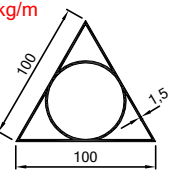
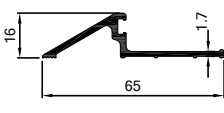
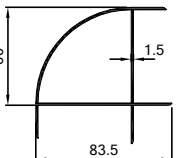
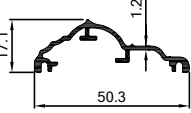
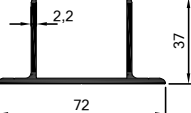
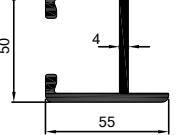
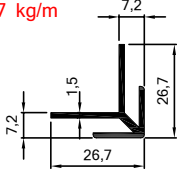
4308 0.446 kg/m 	4042 0.485 kg/m 	7345 0.413 kg/m 	6449 0.459 kg/m 
6464 0.523 kg/m 	7346 0.377 kg/m 	5328 0.449 kg/m 	4309 0.400 kg/m 
6451 0.341 kg/m 	5718 0.349 kg/m 	7347 0.310 kg/m 	5714 1.676 kg/m 
416 0.205 kg/m 	3029 0.092 kg/m 	1580 0.454 kg/m 	960 1.729 kg/m 
1529 1.266 kg/m 	1525 1.942 kg/m 	3965 2.249 kg/m 	1526 1.908 kg/m 
1528 1.444 kg/m 	4674 1.279 kg/m 	1522 6.536 kg/m 	1524 4.178 kg/m 
4672 10.068 kg/m 	4673 4.456 kg/m 	1521 4.474 kg/m 	1523 1.852 kg/m 
5649 0.276 kg/m 	5650 0.227 kg/m 	512 0.298 kg/m 	2829 0.181 kg/m 

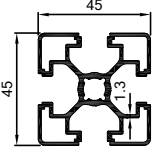
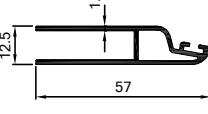
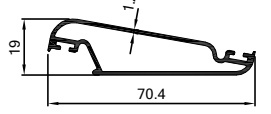
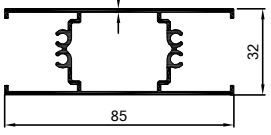
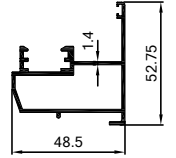
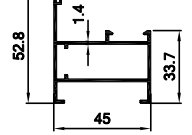
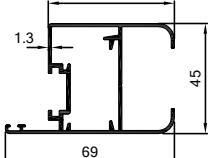
2828 0.257 kg/m 	2827 0.682 kg/m 	1067 0.241 kg/m 	1483 0.973 kg/m 
1484 1.230 kg/m 	5911 0.312 kg/m 	5958 4.846 kg/m 	801 1.099 kg/m 
802 1.455 kg/m 	2282 0.526 kg/m 	2237 0.634 kg/m 	2238 0.638 kg/m 
3817 0.825 kg/m 	3475 0.580 kg/m 	560 0.713 kg/m 	171 0.414 kg/m 
172 0.387 kg/m 	997 1.755 kg/m 	1580 0.454 kg/m 	6422 1.196 kg/m 
2216 0.335 kg/m 	1450 0.875 kg/m 	191 1.840 kg/m 	153 0.307 kg/m 
3137 1.094 kg/m 	5371 1.278 kg/m 	3652 0.514 kg/m 	3653 0.578 kg/m 
3656 1.006 kg/m 	3657 0.808 kg/m 	3654 0.745 kg/m 	3655 0.949 kg/m 

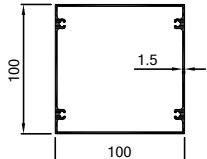
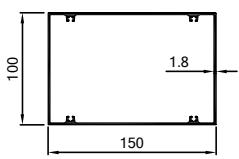
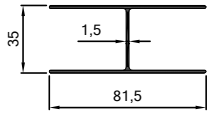
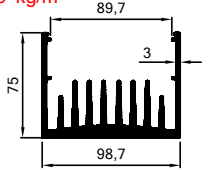
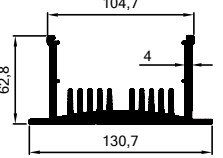
<p>7335 1.935 kg/m</p> 	<p>7336 2.719 kg/m</p> 	<p>8054 0.795 kg/m</p> 	<p>1163 4.865 kg/m</p> 
<p>1164 4.540 kg/m</p> 			

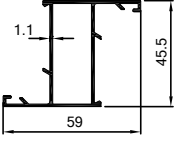
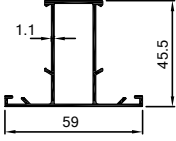
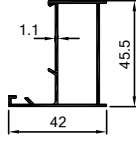
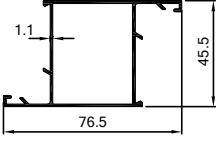
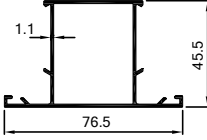
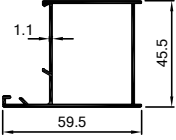
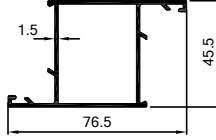
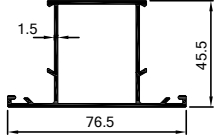
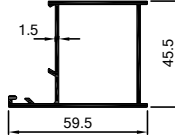
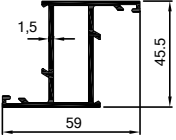
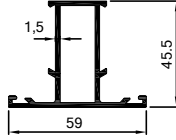
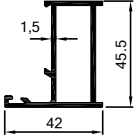
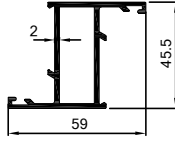
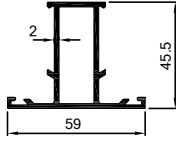
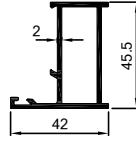
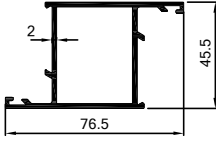
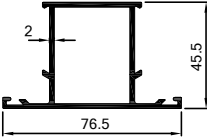
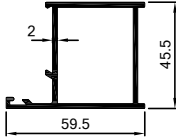
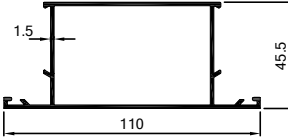
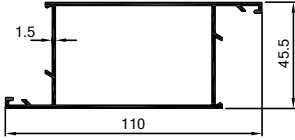
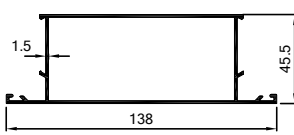
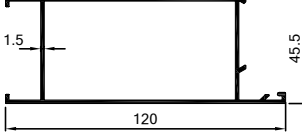
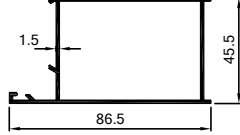
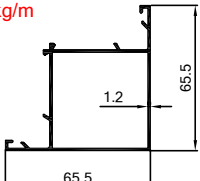
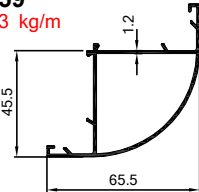
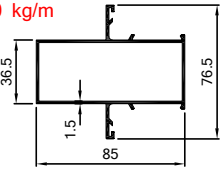
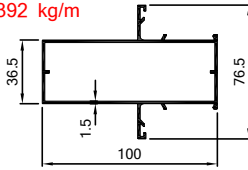
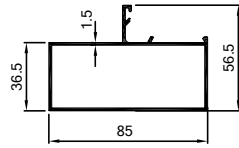
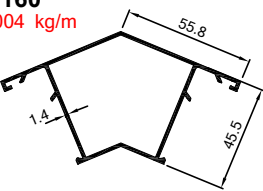
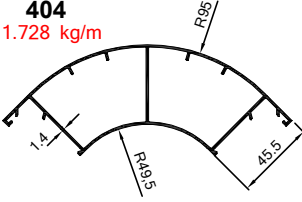
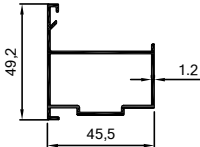
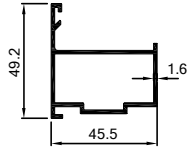
178 0.605 kg/m 	179 0.605 kg/m 	180 0.506 kg/m 	181 0.710 kg/m 
182 0.710 kg/m 	183 0.610 kg/m 	401 0.935 kg/m 	402 0.935 kg/m 
403 0.813 kg/m 	624 0.793 kg/m 	625 0.793 kg/m 	626 0.671 kg/m 
337 0.990 kg/m 	338 0.990 kg/m 	339 0.854 kg/m 	340 1.179 kg/m 
341 1.179 kg/m 	342 1.044 kg/m 	185 1.208 kg/m 	198 1.208 kg/m 
186 1.436 kg/m 	184 1.325 kg/m 	424 1.032 kg/m 	6832 0.824 kg/m 
159 0.763 kg/m 	109 1.260 kg/m 	110 1.392 kg/m 	391 1.111 kg/m 
160 1.004 kg/m 	404 1.728 kg/m 	7397 0.590 kg/m 	267 0.776 kg/m 

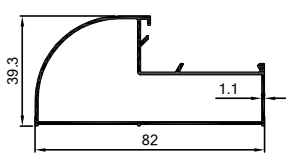
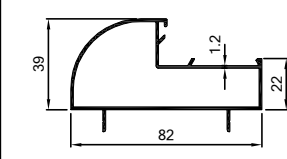
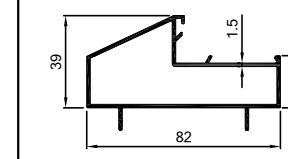
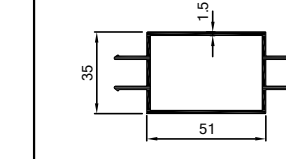
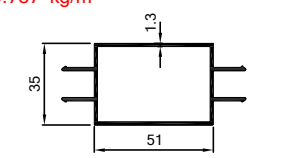
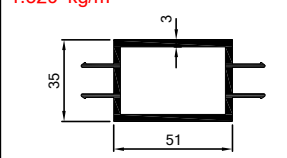
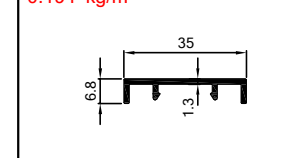
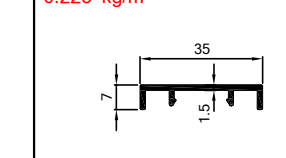
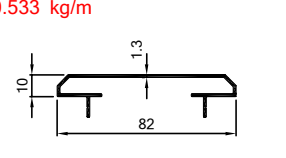
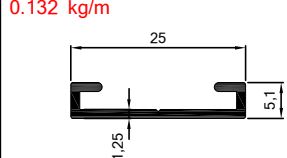
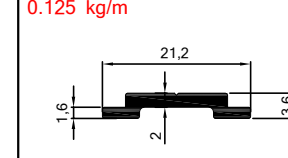
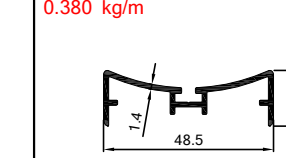
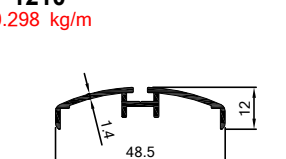
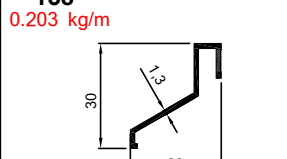
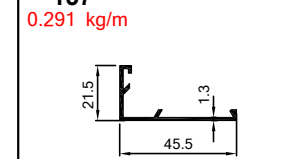
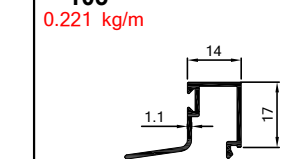
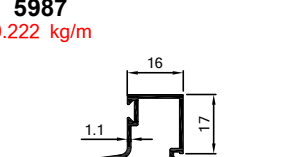
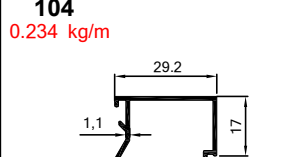
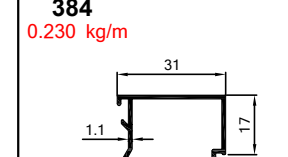
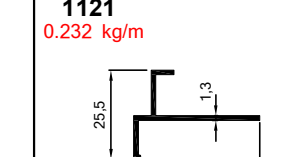
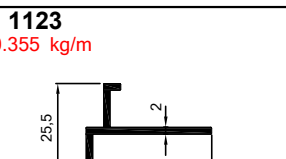
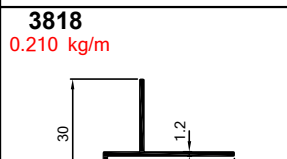
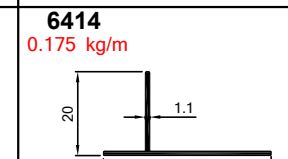
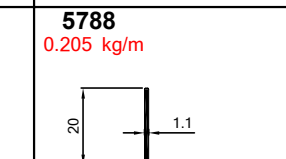
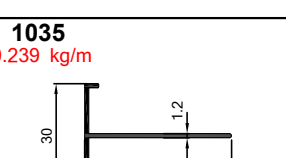
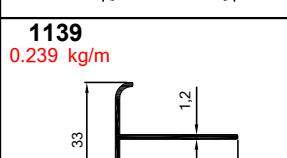
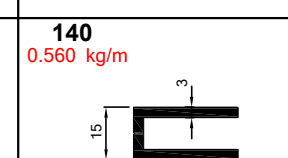
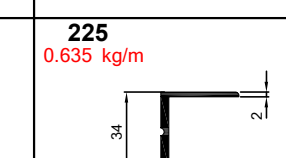
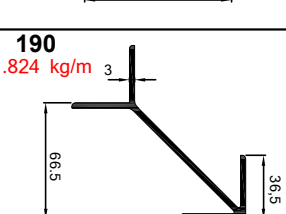
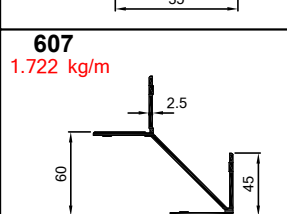
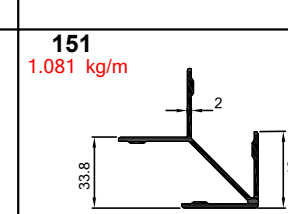
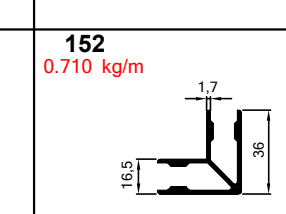
7435 0.732 kg/m 	5344 0.849 kg/m 	415 1.045 kg/m 	501 0.903 kg/m 
504 0.787 kg/m 	3949 1.529 kg/m 	505 0.194 kg/m 	502 0.225 kg/m 
4095 0.533 kg/m 	639 0.132 kg/m 	640 0.125 kg/m 	1209 0.380 kg/m 
1210 0.298 kg/m 	158 0.203 kg/m 	157 0.291 kg/m 	105 0.221 kg/m 
5987 0.222 kg/m 	104 0.234 kg/m 	384 0.230 kg/m 	1121 0.232 kg/m 
1123 0.355 kg/m 	3818 0.210 kg/m 	6414 0.175 kg/m 	5788 0.205 kg/m 
1035 0.239 kg/m 	1139 0.239 kg/m 	140 0.560 kg/m 	225 0.635 kg/m 
190 1.824 kg/m 	607 1.722 kg/m 	151 1.081 kg/m 	152 0.710 kg/m 
185 ve 198 no'lu profillerin köşe bağlantısı	424 no'lu profilin köşe bağlantısı	181-182-183 no'lu profillerin köşe bağlantısı	178-179-180 no'lu profillerin köşe bağlantısı

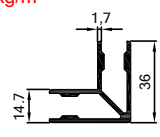
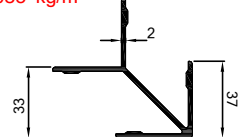
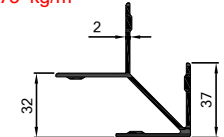
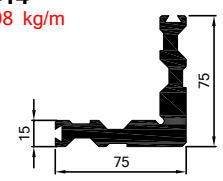
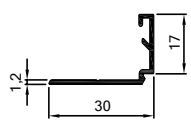
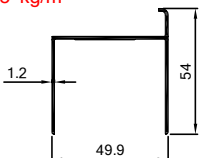
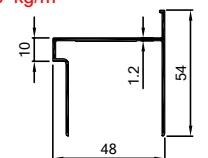
<p>295 0.715 kg/m</p>  <p>337-338-339 no'lu profillerin köşe bağlantısı</p>	<p>381 1.083 kg/m</p>  <p>401-402-403 no'lu profillerin köşe bağlantısı</p>	<p>383 1.075 kg/m</p>  <p>340,341,342 nolu profillerin köşe bağlantısı</p>	<p>414 4.298 kg/m</p> 
<p>481 0.183 kg/m</p> 	<p>5387 0.493 kg/m</p> 	<p>1579 0.500 kg/m</p> 	

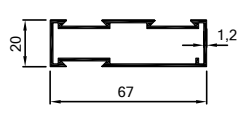
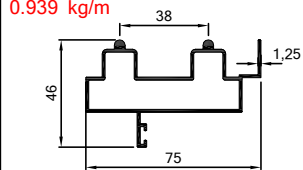
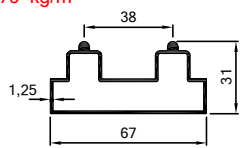
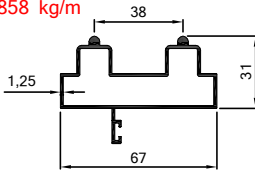
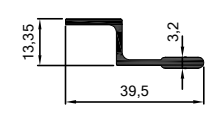
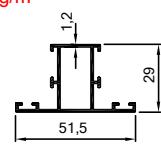
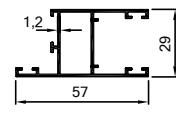
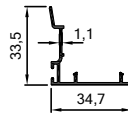
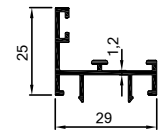
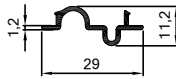
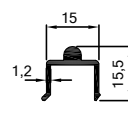
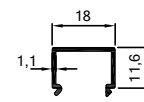
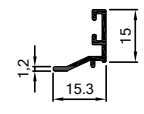
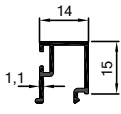
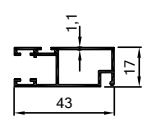
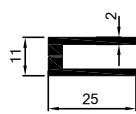
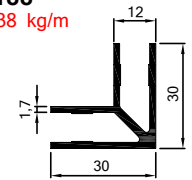
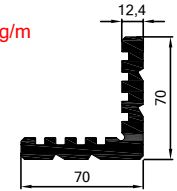
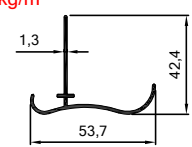
130 0.661 kg/m 	143 0.939 kg/m 	1242 0.779 kg/m 	5329 0.858 kg/m 
1240 0.285 kg/m 	258 0.518 kg/m 	132 0.618 kg/m 	135 0.261 kg/m 
134 0.307 kg/m 	137 0.160 kg/m 	131 0.166 kg/m 	290 0.139 kg/m 
136 0.131 kg/m 	138 0.173 kg/m 	1243 0.434 kg/m 	141 0.346 kg/m 
188 0.538 kg/m 	413 3.667 kg/m 	1241 0.390 kg/m 	

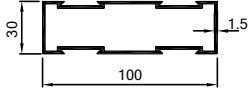
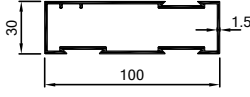
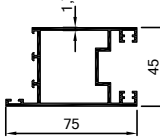
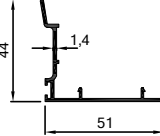
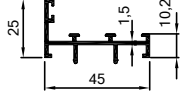
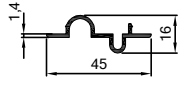
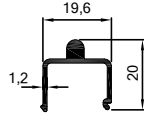
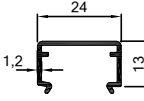
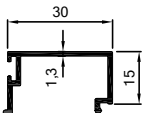
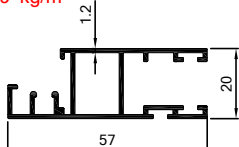
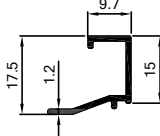
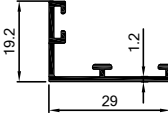
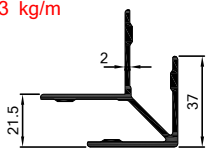
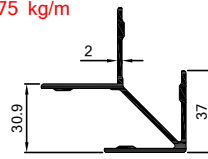
147 1.207 kg/m 	150 1.170 kg/m 	144 1.275 kg/m 	145 0.426 kg/m 
149 0.451 kg/m 	146 0.272 kg/m 	148 0.222 kg/m 	166 0.196 kg/m 
170 0.259 kg/m 	2276 0.609 kg/m 	2277 0.145 kg/m 	1086 0.217 kg/m 
500 1.003 kg/m  <p>147 ve 150 no'lu profillerin çavuş bağlantısı</p>	506 1.075 kg/m  <p>144 no'lu profilin çavuş bağlantısı</p>		

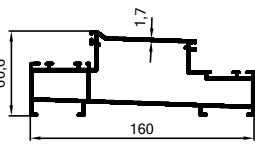
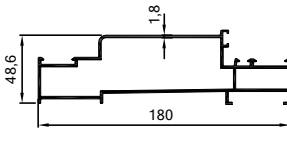
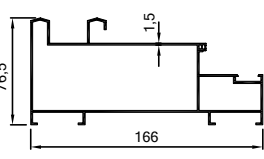
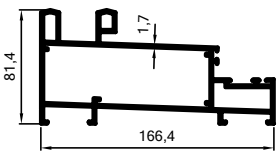
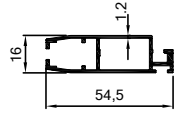
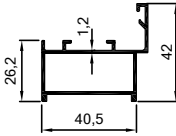
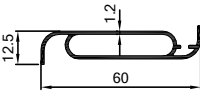
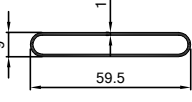
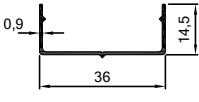
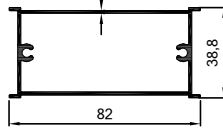

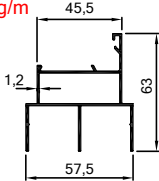
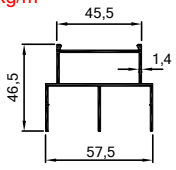
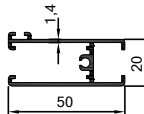
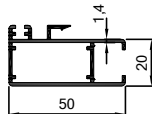
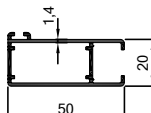
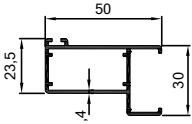
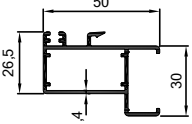
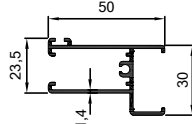
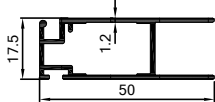
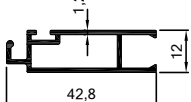
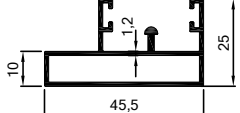
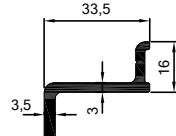
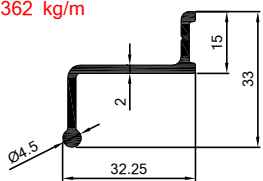
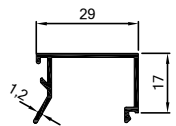
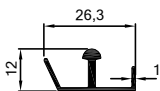
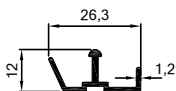
2272 2.480 kg/m 	2275 2.563 kg/m 	2268 2.386 kg/m 	2284 2.957 kg/m 
2265 0.540 kg/m 	2038 0.578 kg/m 	2040 0.448 kg/m 	2042 0.342 kg/m 
2266 0.160 kg/m 	2039 0.954 kg/m 		

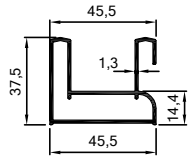
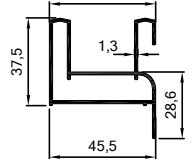
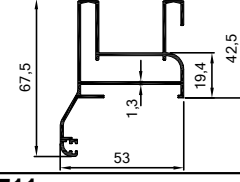
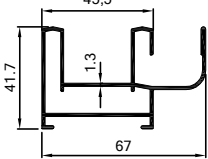
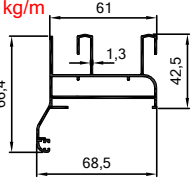
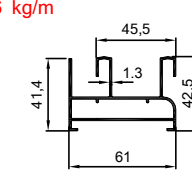
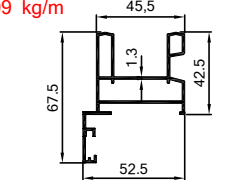
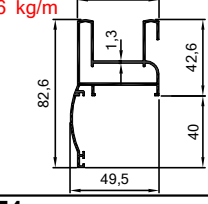
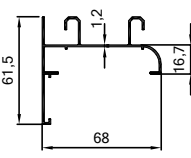
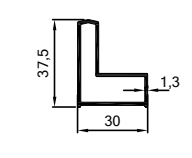
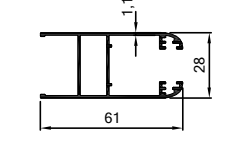
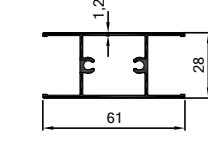
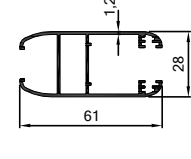
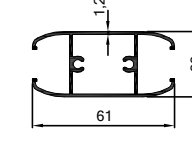
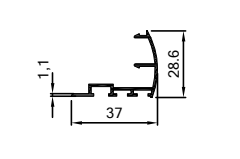
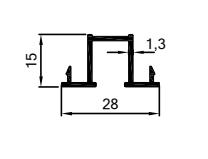
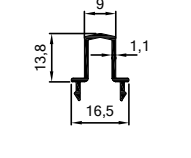
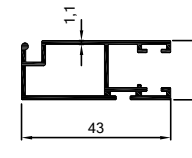
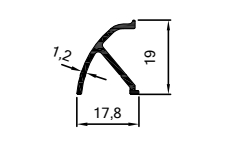
2120 0.864 kg/m 	2132 0.827 kg/m 	2121 0.584 kg/m 	2122 0.676 kg/m 
2123 0.588 kg/m 	2130 0.617 kg/m 	2129 0.694 kg/m 	2131 0.614 kg/m 
2135 0.493 kg/m 	2136 0.368 kg/m 	2137 0.541 kg/m 	2134 0.530 kg/m 
2278 0.362 kg/m 	104 0.245 kg/m 	2124 0.179 kg/m 	2133 0.183 kg/m 

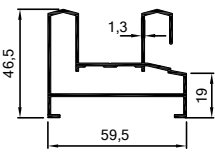
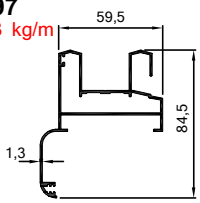
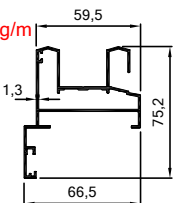
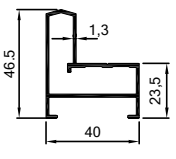
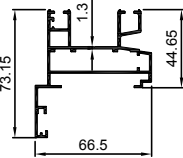
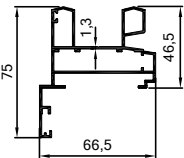
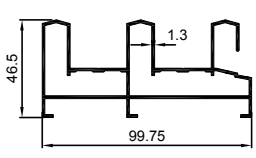
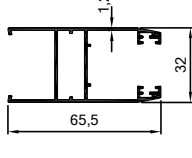
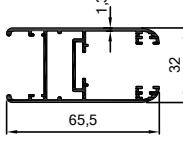
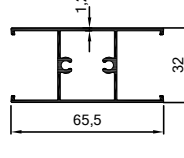
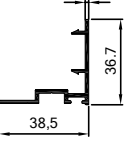
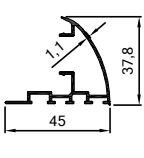
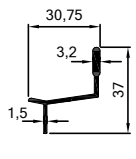
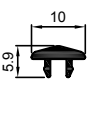
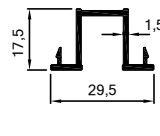
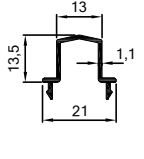
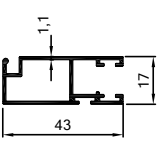
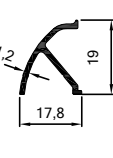
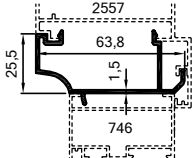
<p>732 0.707 kg/m</p> 	<p>729 0.756 kg/m</p> 	<p>727 0.927 kg/m</p> 	<p>2940 0.936 kg/m</p> 
<p>2041 1.105 kg/m</p> 	<p>2051 0.946 kg/m</p> 	<p>2711 1.009 kg/m</p> 	<p>6236 0.966 kg/m</p> 
<p>728 0.729 kg/m</p> 	<p>761 0.480 kg/m</p> 	<p>730 0.644 kg/m</p> 	<p>754 0.664 kg/m</p> 
<p>757 0.703 kg/m</p> 	<p>753 0.707 kg/m</p> 	<p>731 0.291 kg/m</p> 	<p>775 0.229 kg/m</p> 
<p>756 0.154 kg/m</p> 	<p>1243 0.434 kg/m</p> 	<p>7021 0.140 kg/m</p> 	

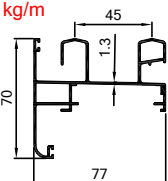
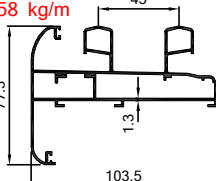
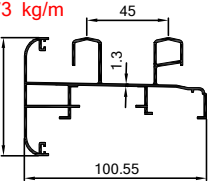
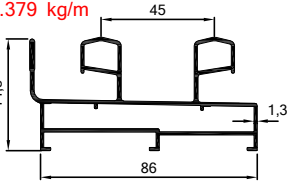
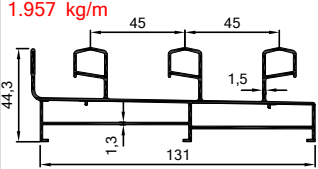
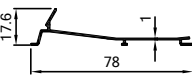
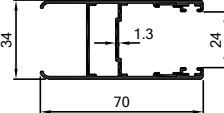
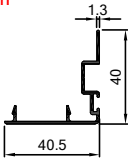
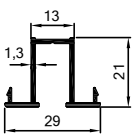
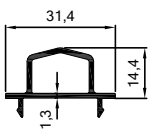
<p>733 0.927 kg/m</p> 	<p>797 1.163 kg/m</p> 	<p>726 1.140 kg/m</p> 	<p>736 0.642 kg/m</p> 
<p>2557 1.299 kg/m</p> 	<p>2637 1.279 kg/m</p> 	<p>3076 1.475 kg/m</p> 	<p>734 0.770 kg/m</p> 
<p>798 0.895 kg/m</p> 	<p>765 0.738 kg/m</p> 	<p>751 0.381 kg/m</p> 	<p>799 0.415 kg/m</p> 
<p>776 0.311 kg/m</p> 	<p>2073 0.068 kg/m</p> 	<p>735 0.279 kg/m</p> 	<p>777 0.171 kg/m</p> 
<p>1243 0.434 kg/m</p> 	<p>7021 0.140 kg/m</p> 	<p>2558 0.572 kg/m</p> 	

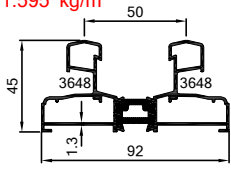
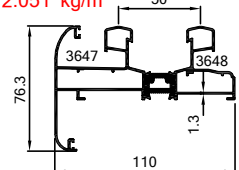
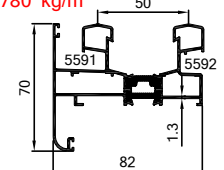
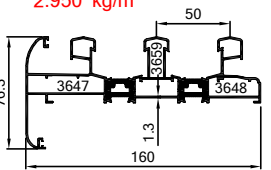
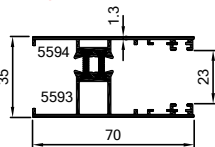
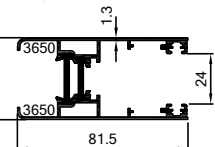
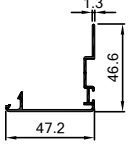
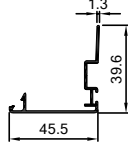
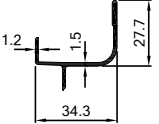
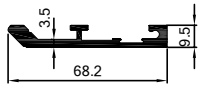
<p>5590 1.277 kg/m</p> 	<p>3641 1.858 kg/m</p> 	<p>3642 1.473 kg/m</p> 	<p>6570 1.379 kg/m</p> 
<p>6571 1.957 kg/m</p> 	<p>3643 0.291 kg/m</p> 	<p>3644 0.887 kg/m</p> 	<p>3645 0.377 kg/m</p> 
<p>4038 0.274 kg/m</p> 	<p>4039 0.288 kg/m</p> 		

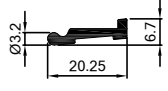
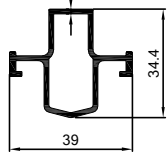
<p>3648 - 3648 1.595 kg/m</p> 	<p>3647 - 3648 2.051 kg/m</p> 	<p>5591 - 5592 1.780 kg/m</p> 	<p>3647-3659-3648 2.950 kg/m</p> 
<p>5593 - 5594 1.108 kg/m</p> 	<p>3650 - 3650 1.412 kg/m</p> 	<p>3651 0.415 kg/m</p> 	<p>5599 0.407 kg/m</p> 
<p>5598 0.302 kg/m</p> 	<p>5595 0.833 kg/m</p> 	<p>5596 0.816 kg/m</p> 	<p>5597 0.151 kg/m</p> 
<p>3649 0.548 kg/m</p> 			

2700-2701
1.649 kg/m

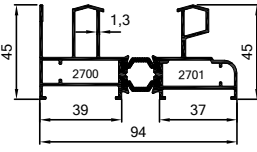

2700-3025
1.812 kg/m

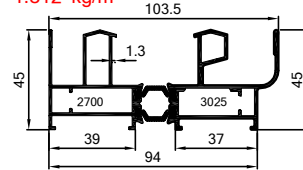

2818-2701
1.847 kg/m

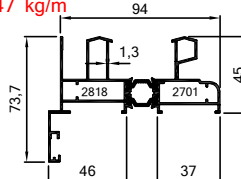

2818-3025
2.016 kg/m

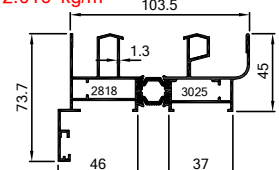

2700-2704-2701
2.523 kg/m

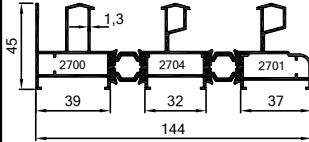

2700-2704-3025
2.700 kg/m

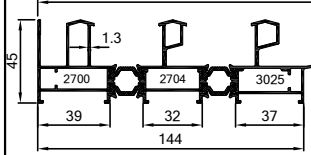

2818-2704-2701
2.721 kg/m

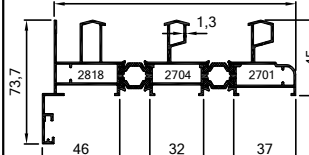

2818-2704-3025
2.898 kg/m

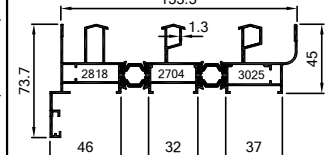

2702-2702
1.540 kg/m

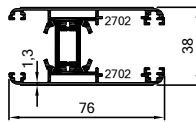

2702-2811
1.438 kg/m

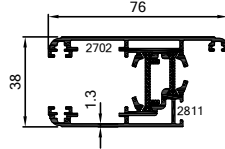

2705-2705
1.473 kg/m

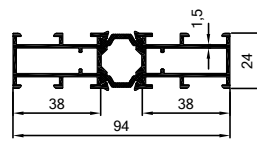

2798-2798
1.021 kg/m

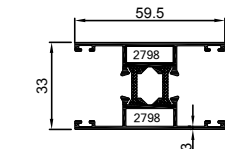

2812-2813
0.883 kg/m

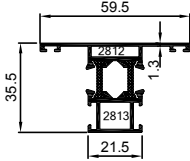

2703
0.403 kg/m

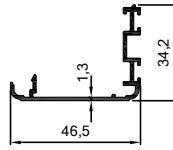

2819
0.096 kg/m

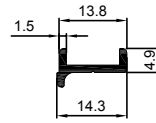

2707
0.190 kg/m

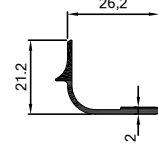

2814
0.151 kg/m

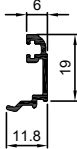

2189
0.184 kg/m

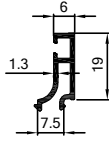

1932-1933
1.478 kg/m

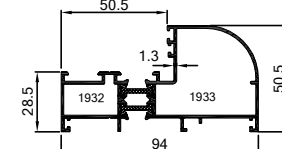

3593-2701
1.948 kg/m

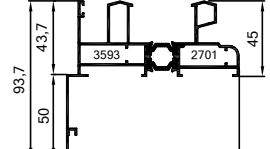

2811 nolu profile çalışır.

3580-3581
1.749 kg/m

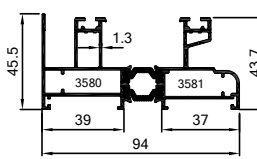

2811 nolu profile çalışır.

3580-3582
1.902 kg/m

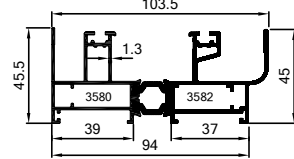

3592-3582
2.128 kg/m

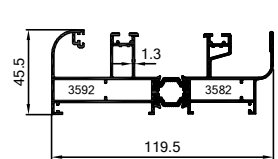

3583-3581
1.981 kg/m

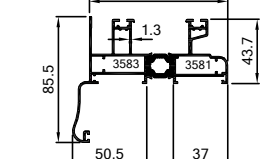

3582-3583
2.134 kg/m

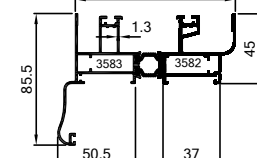

3580-3584-3581
2.662 kg/m

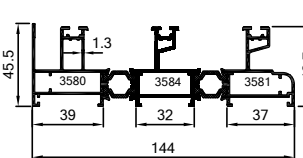

3580-3584-3582
2.815 kg/m

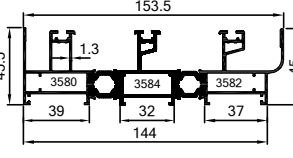

3583-3584-3581
2.894 kg/m

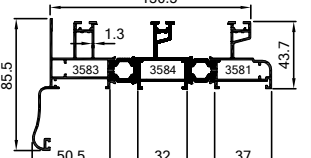

3583-3584-3582
3.047 kg/m

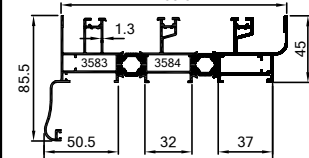

3585-3586
1.289 kg/m

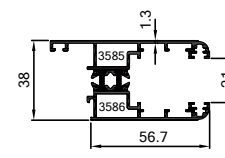

3588-3588
1.134 kg/m

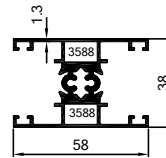

3588-3589
0.942 kg/m

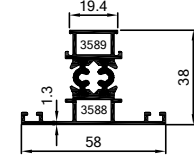

3590-3590
0.454 kg/m

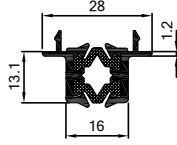

3587
0.140 kg/m

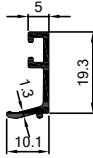

3586 nolu profile çalışır.

3591
0.112 kg/m

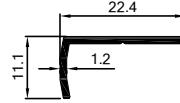

5846-3581
1.799 kg/m

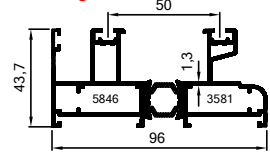

5846-3582
1.952 kg/m

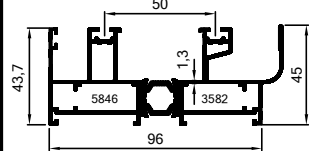

5847-3581
2.031 kg/m

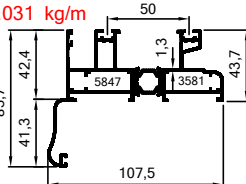

5847-3582
2.185 kg/m

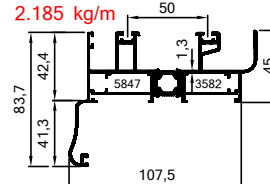

5846-3584-3581
2.713 kg/m

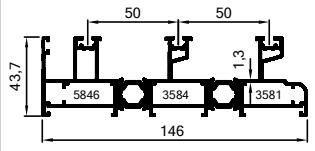

5846-3584-3582
2.866 kg/m

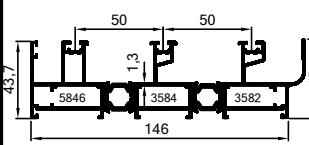

5847-3584-3581
2.946 kg/m

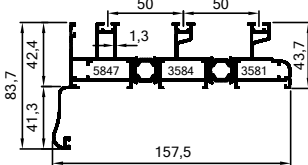

5847-3584-3582
3.098 kg/m

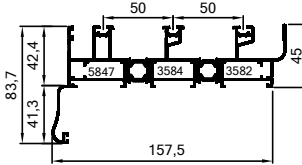

2706
0.474 kg/m

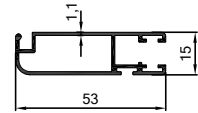

3594
0.456 kg/m

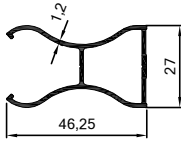

3595
0.101 kg/m

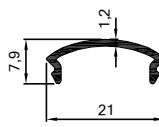

1243
0.434 kg/m

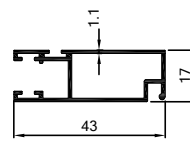

1684
0.326 kg/m

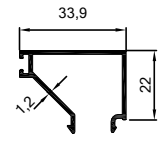

598
1.760 kg/m

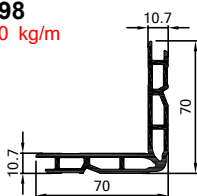

2705 ve Kasa profilleri ile çalışır.

1662
2.591 kg/m

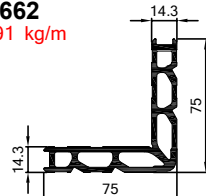

1932,1933 ve 3585-3586 profiller ile çalışır.

296
1.032 kg/m

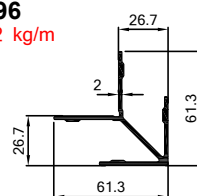

2706 nolu profilin çavuş bağlantısı

8267
0.086 kg/m

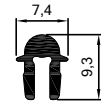

6877
0.061 kg/m

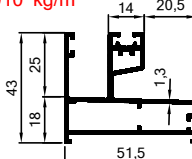
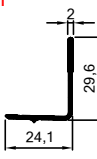
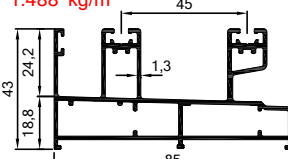
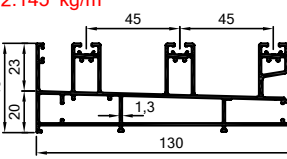
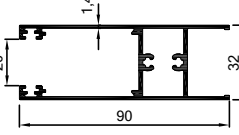
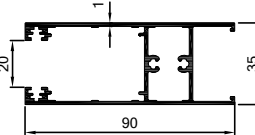
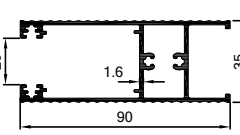
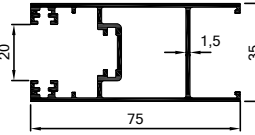
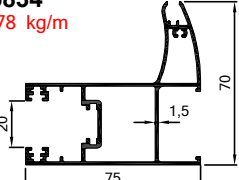
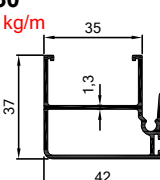
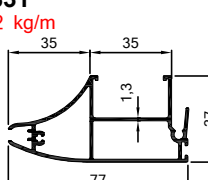
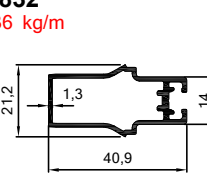
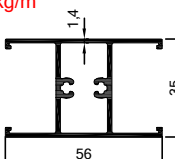
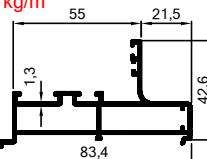
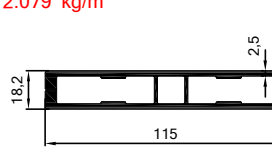
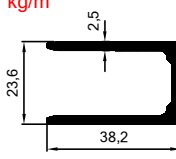
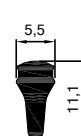
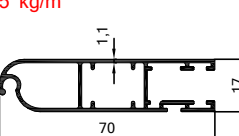
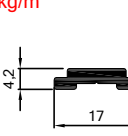
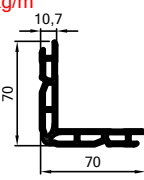

<p>5820 0.910 kg/m</p> 	<p>5821 0.220 kg/m</p> 	<p>5822 1.488 kg/m</p> 	<p>5823 2.145 kg/m</p> 
<p>5824 1.198 kg/m</p> 	<p>5848 1.311 kg/m</p> 	<p>5825 1.330 kg/m</p> 	<p>5833 1.074 kg/m</p> 
<p>5834 1.378 kg/m</p> 	<p>5830 0.613 kg/m</p> 	<p>5831 0.982 kg/m</p> 	<p>5832 0.436 kg/m</p> 
<p>5850 0.842 kg/m</p> 	<p>5851 0.988 kg/m</p> 	<p>5836 2.079 kg/m</p> 	<p>5835 0.653 kg/m</p> 
<p>5844 0.104 kg/m</p> 	<p>5829 0.655 kg/m</p> 	<p>5845 0.141 kg/m</p> 	<p>598 1.760 kg/m</p> 

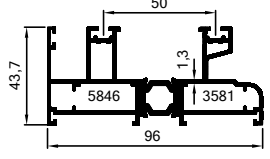
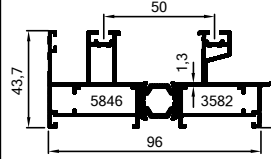
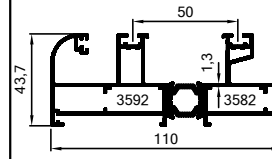
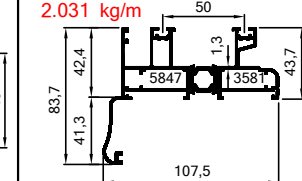
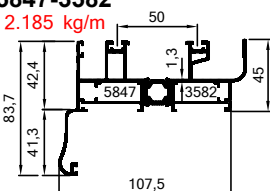
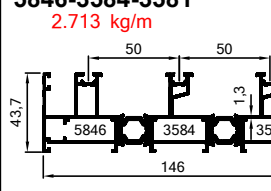
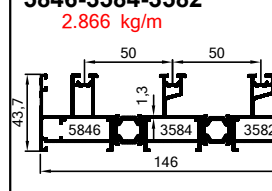
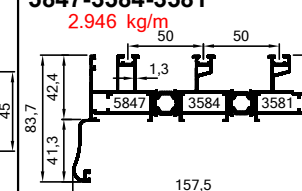
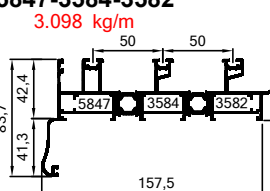
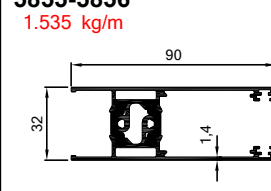
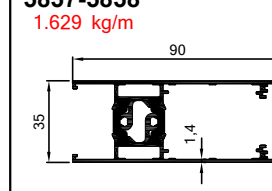
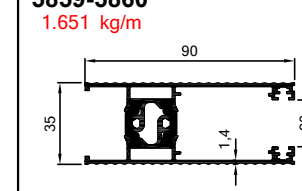
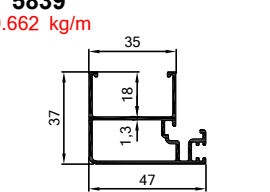
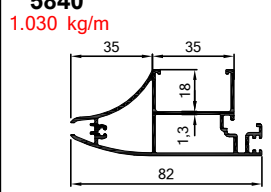
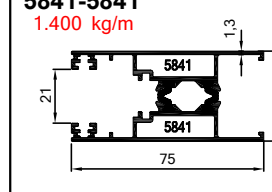
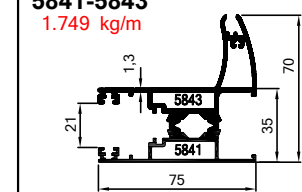
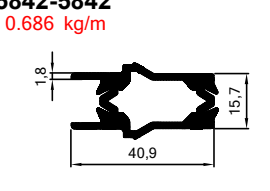
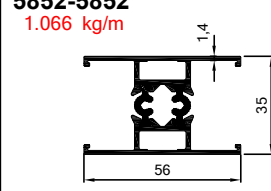
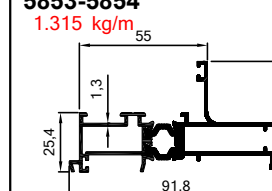
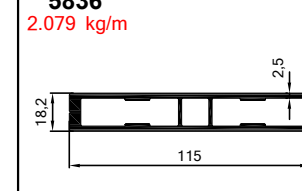
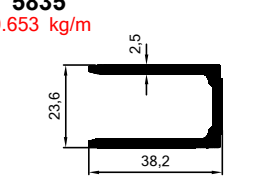
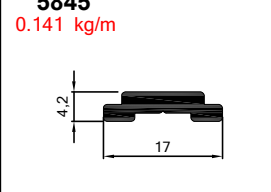
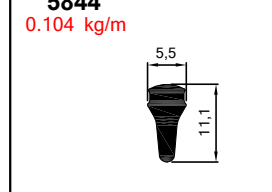
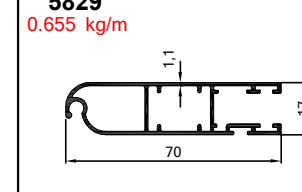
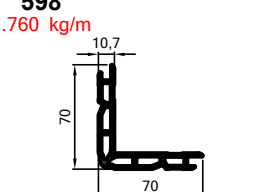
<p>5846-3581 1.799 kg/m</p> 	<p>5846-3582 1.952 kg/m</p> 	<p>3592-3582 2.140 kg/m</p> 	<p>5847-3581 2.031 kg/m</p> 
<p>5847-3582 2.185 kg/m</p> 	<p>5846-3584-3581 2.713 kg/m</p> 	<p>5846-3584-3582 2.866 kg/m</p> 	<p>5847-3584-3581 2.946 kg/m</p> 
<p>5847-3584-3582 3.098 kg/m</p> 	<p>5855-5856 1.535 kg/m</p> 	<p>5857-5858 1.629 kg/m</p> 	<p>5859-5860 1.651 kg/m</p> 
<p>5839 0.662 kg/m</p> 	<p>5840 1.030 kg/m</p> 	<p>5841-5841 1.400 kg/m</p> 	<p>5841-5843 1.749 kg/m</p> 
<p>5842-5842 0.686 kg/m</p> 	<p>5852-5852 1.066 kg/m</p> 	<p>5853-5854 1.315 kg/m</p> 	<p>5836 2.079 kg/m</p> 
<p>5835 0.653 kg/m</p> 	<p>5845 0.141 kg/m</p> 	<p>5844 0.104 kg/m</p> 	<p>5829 0.655 kg/m</p> 
<p>598 1.760 kg/m</p> 			

6000-6001
2.598 kg/m

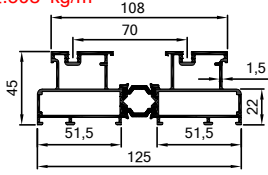

6002-6003
3.044 kg/m

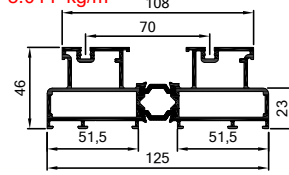

6004-6005
1.890 kg/m

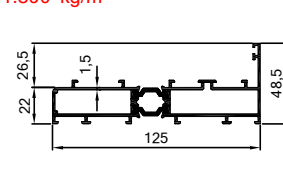

6006
0.510 kg/m

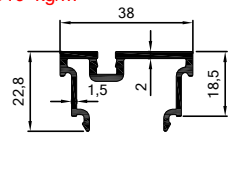

6012-6013
2.127 kg/m

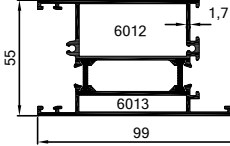

6000 - 6024 - 6001
4.046 kg/m

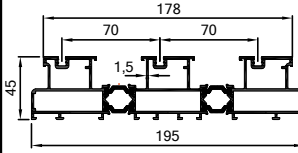

6008-6009
2.033 kg/m

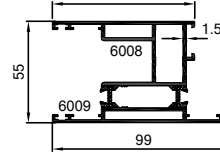

6010-6011
2.203 kg/m

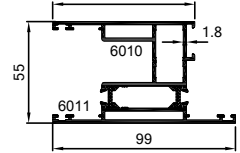

1700-1716
1.377 kg/m

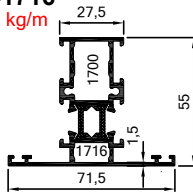

1702-1761
1.560 kg/m

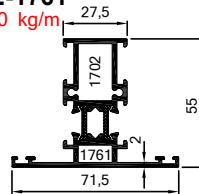

1704-1717
1.615 kg/m

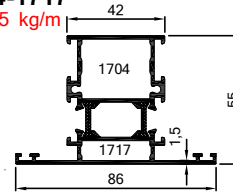

1706-1718
1.877 kg/m

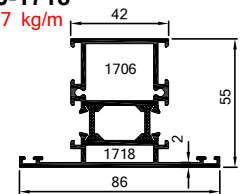

6022
0.688 kg/m

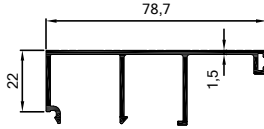

6014-6015
0.866 kg/m

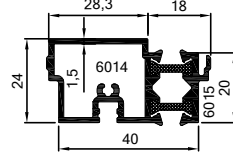

6016
0.419 kg/m

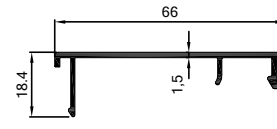

6020
0.461 kg/m

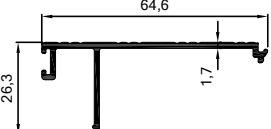

6021
0.570 kg/m

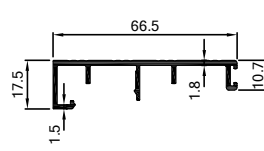

1662
2.591 kg/m

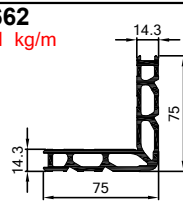

1663
3.578 kg/m

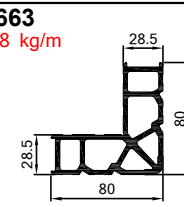

(1757 nin ekonomik olanı)

6019
0.148 kg/m

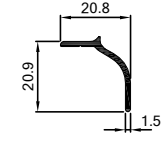

6018
0.120 kg/m

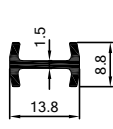

6017
0.327 kg/m

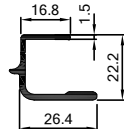

4242
0.094 kg/m

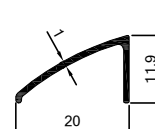

1948
0.239 kg/m

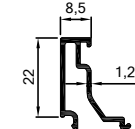

1698
0.256 kg/m

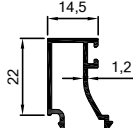

3539
0.260 kg/m

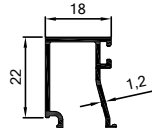

1699
0.268 kg/m

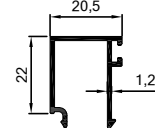

1745
0.279 kg/m

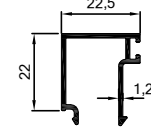

1949
0.313 kg/m

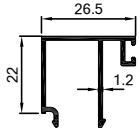

2236
0.316 kg/m

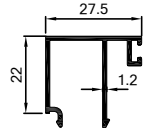

1966
0.320 kg/m

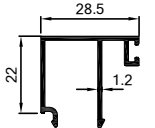

3636
0.327 kg/m

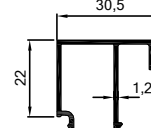

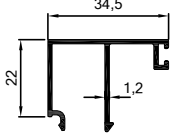
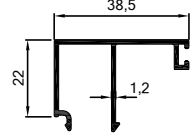
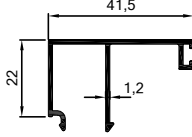
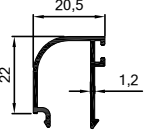
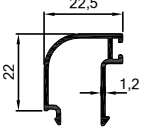
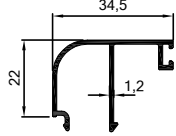
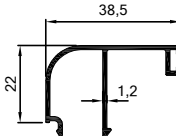
<p>1747 0.341 kg/m</p> 	<p>1749 0.355 kg/m</p> 	<p>3537 0.366 kg/m</p> 	<p>5546 0.255 kg/m</p> 
<p>1746 0.266 kg/m</p> 	<p>1748 0.327 kg/m</p> 	<p>1750 0.341 kg/m</p> 	

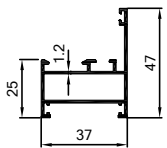
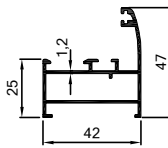
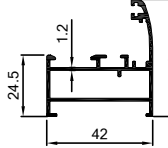
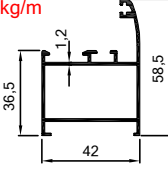
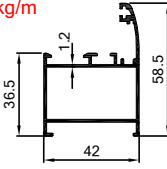
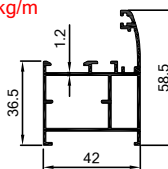
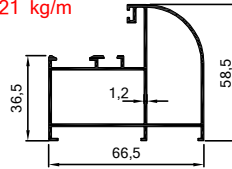
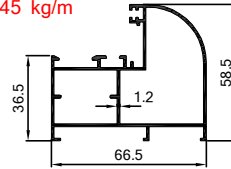
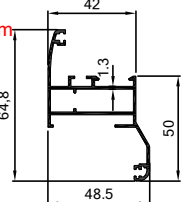
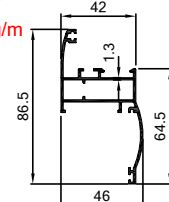
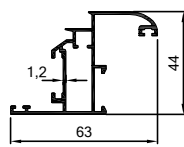
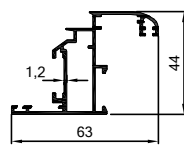
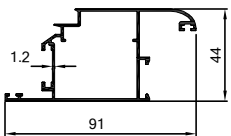
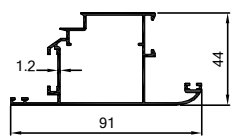
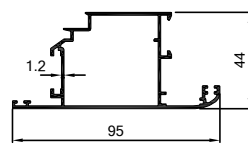
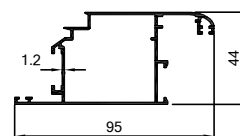
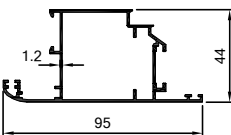
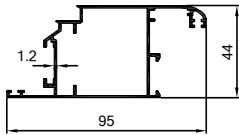
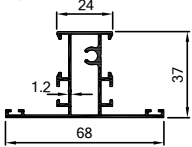
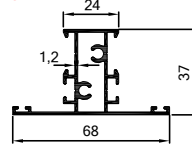
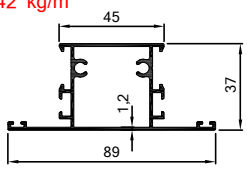
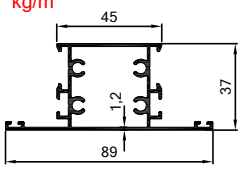
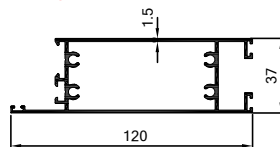
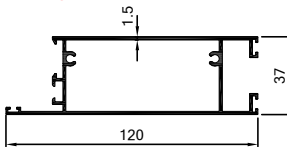
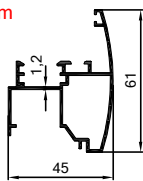
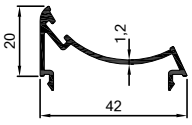
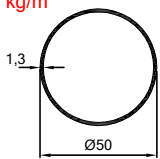
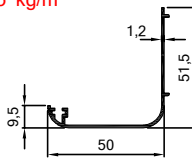
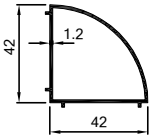
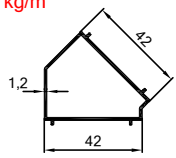
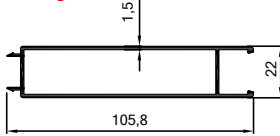
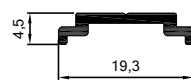
3915 0.572 kg/m 	766 0.632 kg/m 	707 0.649 kg/m 	794 0.700 kg/m 
596 0.719 kg/m 	708 0.812 kg/m 	763 1.021 kg/m 	709 1.045 kg/m 
762 0.833 kg/m 	6237 0.875 kg/m 	773 0.728 kg/m 	710 0.757 kg/m 
768 0.933 kg/m 	795 0.933 kg/m 	691 0.977 kg/m 	692 0.977 kg/m 
599 0.997 kg/m 	600 0.997 kg/m 	769 0.752 kg/m 	713 0.809 kg/m 
767 0.942 kg/m 	714 1.057 kg/m 	715 1.532 kg/m 	752 1.413 kg/m 
760 0.724 kg/m 	759 0.307 kg/m 	755 0.541 kg/m 	764 0.385 kg/m 
2240 0.499 kg/m 	758 0.460 kg/m 	785 1.017 kg/m 	8241 0.099 kg/m 

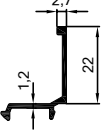
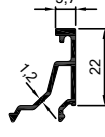
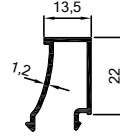
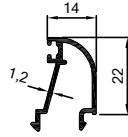
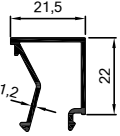
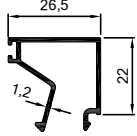
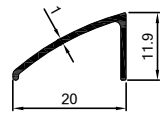
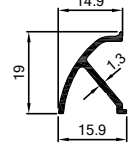
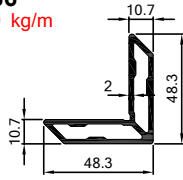
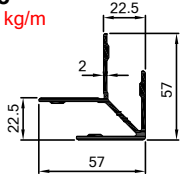
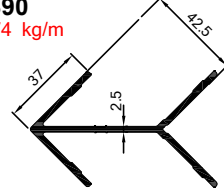
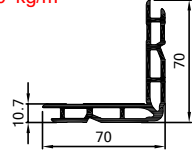
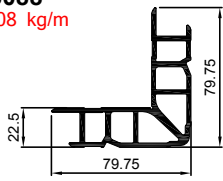
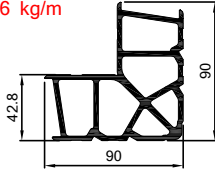
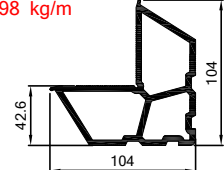
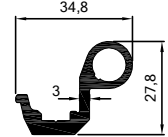
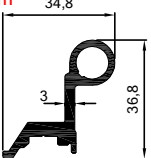
<p>771 0.163 kg/m</p> 	<p>772 0.221 kg/m</p> 	<p>793 0.235 kg/m</p> 	<p>791 0.246 kg/m</p> 
<p>770 0.271 kg/m</p> 	<p>792 0.301 kg/m</p> 	<p>4242 0.094 kg/m</p> 	<p>7021 0.140 kg/m</p> 
<p>386 1.080 kg/m</p>  <p>643,649,766 ve 773 nolu profillerin çavuş bağlantısı</p>	<p>388 1.006 kg/m</p>  <p>644,646,763 ve 794 nolu profillerin çavuş bağlantısı</p>	<p>390 1.374 kg/m</p>  <p>691 ve 692 nolu profillerin çavuş bağlantısı</p>	<p>598 1.760 kg/m</p>  <p>707 nolu profilin köşe takozu</p>
<p>3088 2.608 kg/m</p>  <p>763 ve 794 nolu profillerin köşe takozu</p>	<p>597 4.336 kg/m</p>  <p>691 ve 692 nolu profillerin köşe takozu</p>	<p>4777 4.598 kg/m</p>  <p>691 ve 692 nolu profillerin köşe takozu</p>	<p>667 0.612 kg/m</p> 
<p>668 0.645 kg/m</p> 			

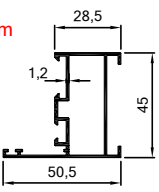
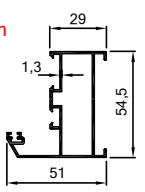
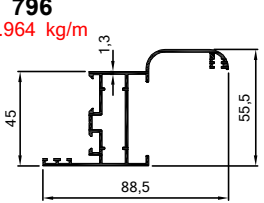
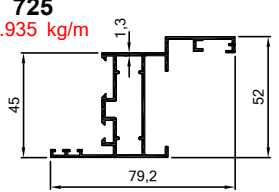
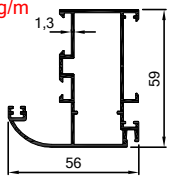
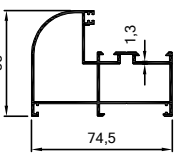
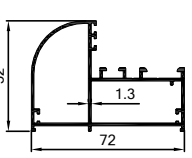
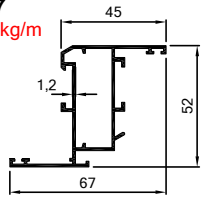
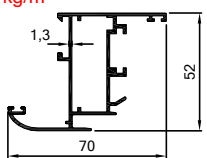
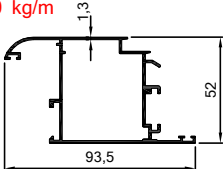
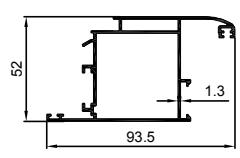
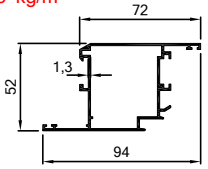
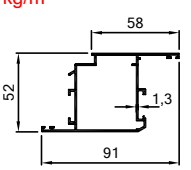
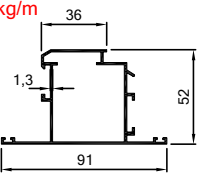
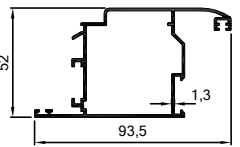
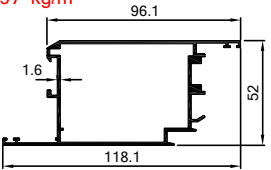
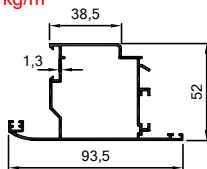
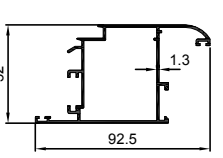
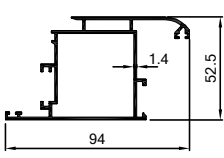
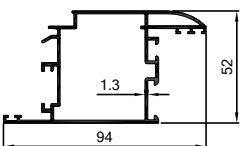
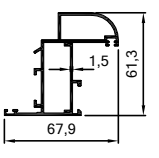
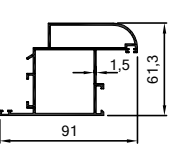
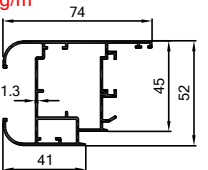
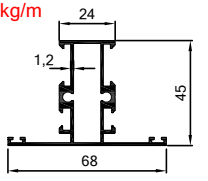
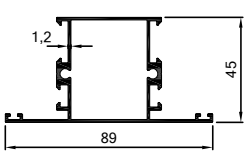
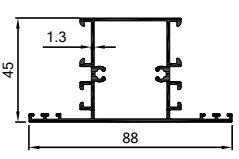
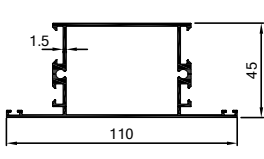
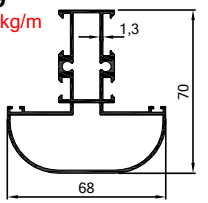
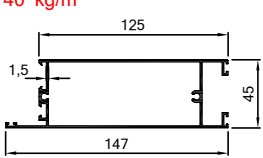
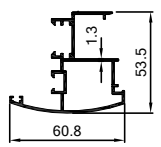
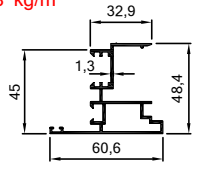
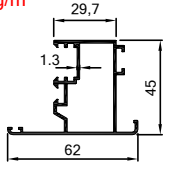
746 0.672 kg/m 	788 0.838 kg/m 	796 0.964 kg/m 	725 0.935 kg/m 
778 0.990 kg/m 	782 1.149 kg/m 	623 1.082 kg/m 	747 0.799 kg/m 
779 0.952 kg/m 	780 1.100 kg/m 	686 1.186 kg/m 	748 1.093 kg/m 
787 1.022 kg/m 	790 1.022 kg/m 	737 1.089 kg/m 	631 1.497 kg/m 
738 1.089 kg/m 	635 1.081 kg/m 	609 1.238 kg/m 	622 1.223 kg/m 
774 1.144 kg/m 	781 1.385 kg/m 	5923 1.157 kg/m 	745 0.881 kg/m 
749 1.018 kg/m 	621 1.094 kg/m 	608 1.338 kg/m 	789 1.261 kg/m 
750 1.740 kg/m 	610 0.885 kg/m 	783 0.828 kg/m 	739 0.821 kg/m 

641-642
1.027 kg/m

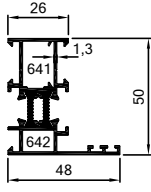

643-644
1.199 kg/m

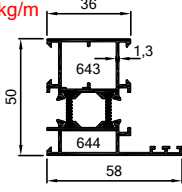

641-645
1.114 kg/m

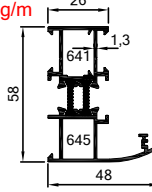

643-646
1.286 kg/m

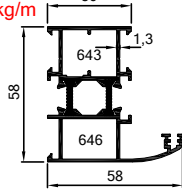

647-648
1.170 kg/m

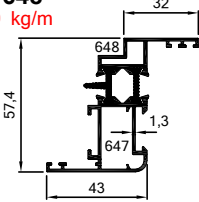

649-650
1.322 kg/m

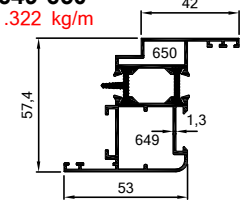

638-642
1.234 kg/m

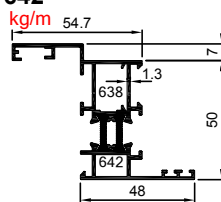

638-645
1.101 kg/m

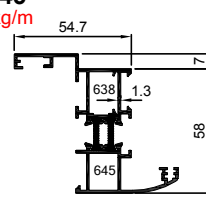

601-602
1.389 kg/m

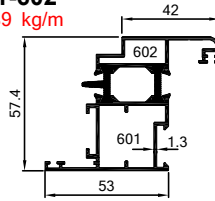

677-678
1.711 kg/m

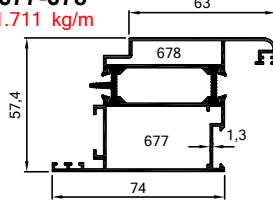

651-652
1.807 kg/m

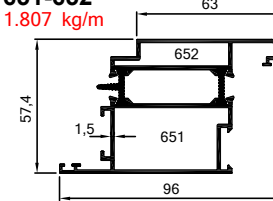

605-685
1.730 kg/m

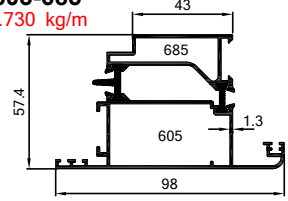

684-685
1.738 kg/m

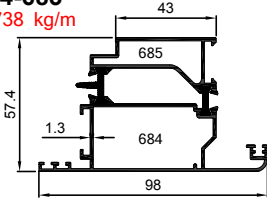

655-656
1.152 kg/m

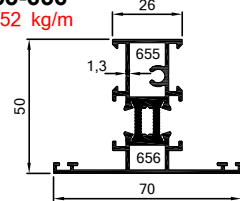

657-603
1.469 kg/m

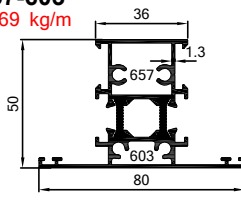

657-658
1.378 kg/m

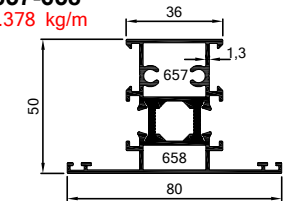

659-604
2.409 kg/m

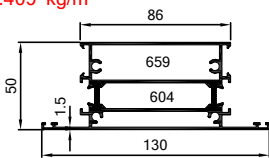

659-660
2.325 kg/m

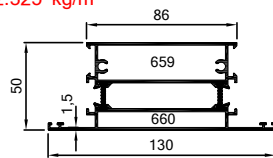

604-661
2.506 kg/m

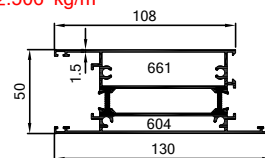

660-661
2.422 kg/m

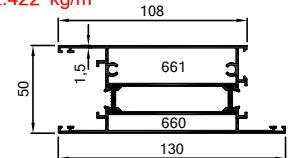

711-682
1.204 kg/m

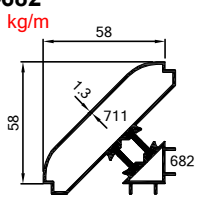

681-682
1.075 kg/m

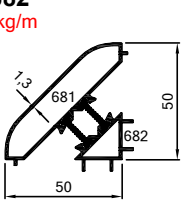

1734-1735
1.457 kg/m

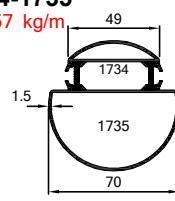

662-663
1.166 kg/m

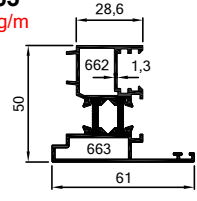

637
0.181 kg/m

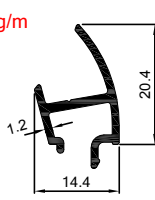

664
0.266 kg/m

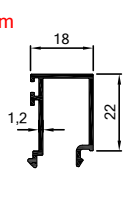

665
0.253 kg/m

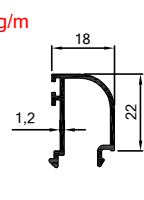

712
0.245 kg/m

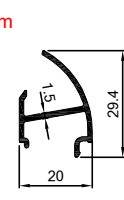

676
0.331 kg/m

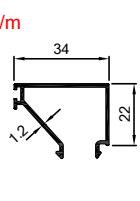

606
0.299 kg/m

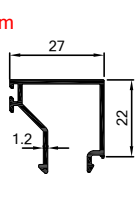

386
1.080 kg/m

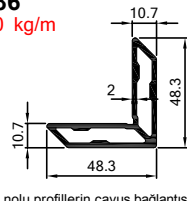

387
0.963 kg/m

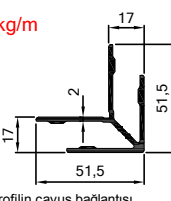

643,649 nolu profillerin çavuş bağlantısı

650 nolu profilin çavuş bağlantısı

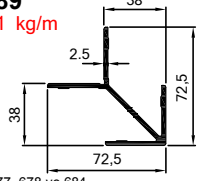
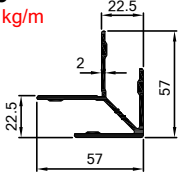
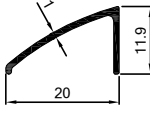
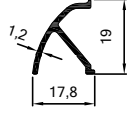
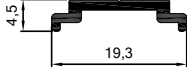
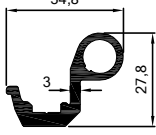
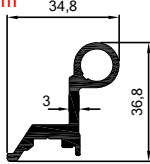
<p>389 1.331 kg/m</p>  <p>605, 677, 678 ve 684 nolu profillerin çavuş bağlantısı</p>	<p>388 1.006 kg/m</p>  <p>644,646 nolu profillerin çavuş bağlantısı</p>	<p>4242 0.094 kg/m</p> 	<p>7021 0.140 kg/m</p> 
<p>8241 0.099 kg/m</p> 	<p>667 0.612 kg/m</p> 	<p>668 0.645 kg/m</p> 	

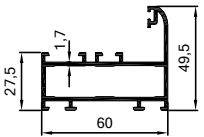
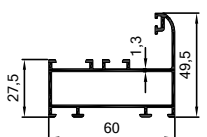
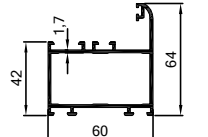
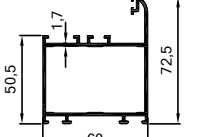
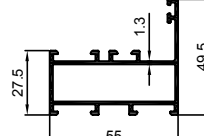
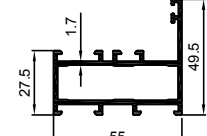
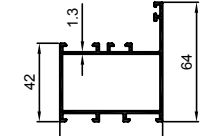
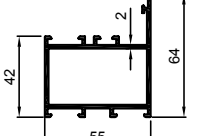
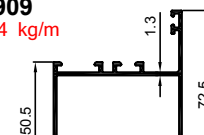
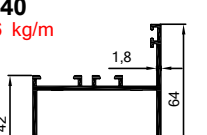
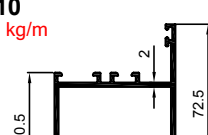
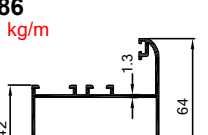
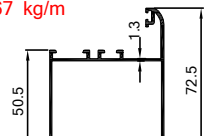
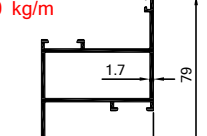
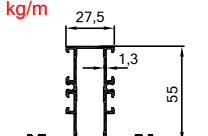
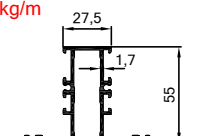
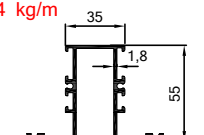
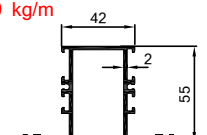
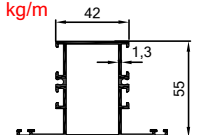
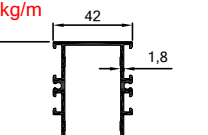
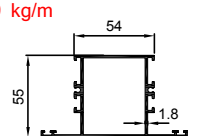
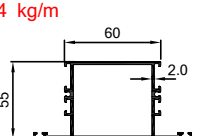
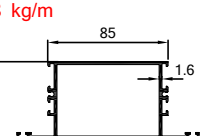
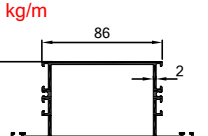
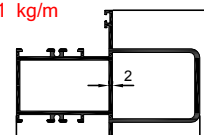
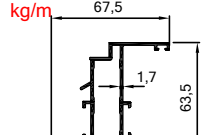
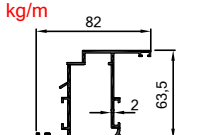
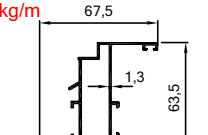
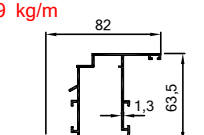
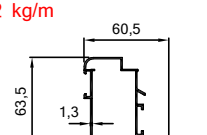
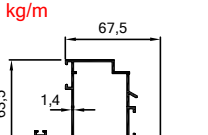
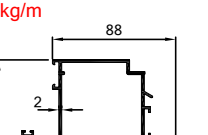
<p>1780 1.135 kg/m</p> 	<p>1685 0.905 kg/m</p> 	<p>1781 1.269 kg/m</p> 	<p>1782 1.347 kg/m</p> 
<p>1905 0.831 kg/m</p> 	<p>1906 1.033 kg/m</p> 	<p>1907 0.934 kg/m</p> 	<p>1908 1.282 kg/m</p> 
<p>1909 0.994 kg/m</p> 	<p>3540 1.196 kg/m</p> 	<p>1910 1.374 kg/m</p> 	<p>1686 1.008 kg/m</p> 
<p>1687 1.067 kg/m</p> 	<p>5580 1.110 kg/m</p> 	<p>1693 1.001 kg/m</p> 	<p>1790 1.225 kg/m</p> 
<p>5156 1.314 kg/m</p> 	<p>1783 1.489 kg/m</p> 	<p>1694 1.103 kg/m</p> 	<p>3541 1.394 kg/m</p> 
<p>1901 1.499 kg/m</p> 	<p>5520 1.684 kg/m</p> 	<p>4687 1.648 kg/m</p> 	<p>1788 1.966 kg/m</p> 
<p>2096 2.321 kg/m</p> 	<p>1784 1.180 kg/m</p> 	<p>1785 1.467 kg/m</p> 	<p>1691 0.942 kg/m</p> 
<p>1692 1.049 kg/m</p> 	<p>3545 1.052 kg/m</p> 	<p>5158 1.206 kg/m</p> 	<p>1786 1.820 kg/m</p> 

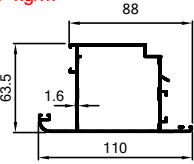
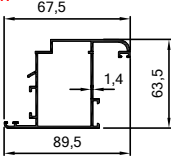
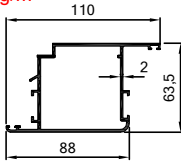
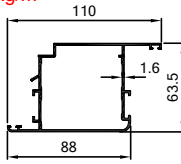
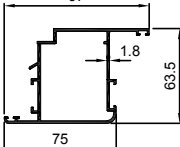
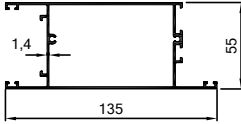
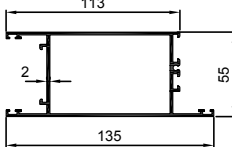
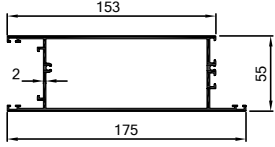
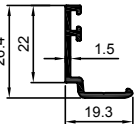
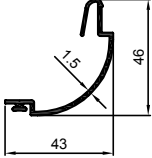
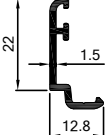
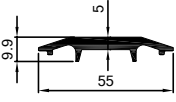
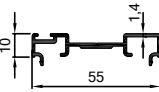
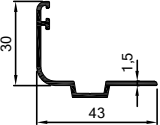
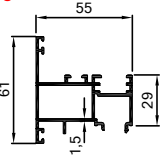
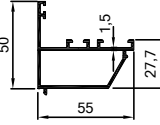
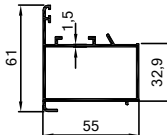
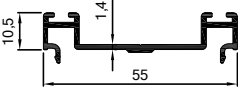
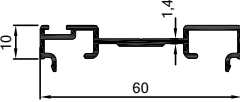
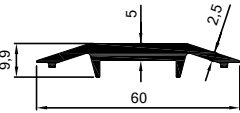
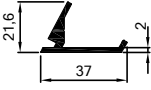
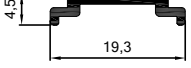
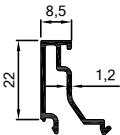
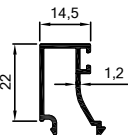
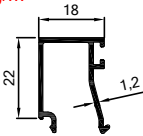
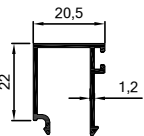
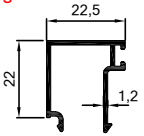
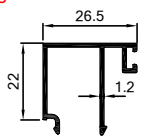
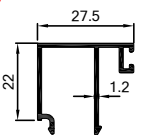
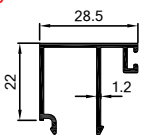
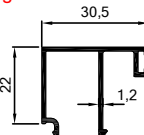
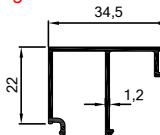
3943 1.559 kg/m 	5157 1.206 kg/m 	1787 1.772 kg/m 	1660 1.517 kg/m 
1900 1.497 kg/m 	5519 1.614 kg/m 	1902 2.114 kg/m 	1789 2.588 kg/m 
1912 0.211 kg/m 	1911 0.425 kg/m 	4251 0.182 kg/m 	1913 0.621 kg/m 
1779 0.439 kg/m 	1681 0.340 kg/m 	1791 1.082 kg/m 	1792 0.829 kg/m 
1793 0.950 kg/m 	6569 0.419 kg/m 	1794 0.461 kg/m 	1795 0.638 kg/m 
1011 0.402 kg/m 	8241 0.099 kg/m 	1948 0.239 kg/m 	1698 0.256 kg/m 
3539 0.260 kg/m 	1699 0.268 kg/m 	1745 0.279 kg/m 	1949 0.313 kg/m 
2236 0.316 kg/m 	1966 0.320 kg/m 	3636 0.327 kg/m 	1747 0.341 kg/m 

1685,1686,1687,1780,1781 ve 1782 notu profiller ile çalışır.

<p>1749 0.355 kg/m</p>	<p>5546 0.255 kg/m</p>	<p>1746 0.266 kg/m</p>	<p>1748 0.327 kg/m</p>
<p>1750 0.341 kg/m</p>	<p>1722 0.623 kg/m</p> <p><small>1704,1706,1717,1718,1783 ve 2096 nolu profiller ile çalışır.</small></p>	<p>1662 2.591 kg/m</p> <p><small>(1756 nin ekonomik alanı)</small></p>	<p>1695 2.602 kg/m</p>
<p>1663 3.578 kg/m</p> <p><small>(1757 nin ekonomik alanı)</small></p>	<p>1696 3.355 kg/m</p>	<p>1664 4.127 kg/m</p> <p><small>(1758 in ekonomik alanı)</small></p>	<p>1697 4.330 kg/m</p>
<p>1903 6.225 kg/m</p>	<p>1398 5.089 kg/m</p> <p><small>(1759 un ekonomik alanı)</small></p>	<p>1777 1.125 kg/m</p>	<p>1752 0.640 kg/m</p>
<p>1753 0.565 kg/m</p>	<p>1682 0.811 kg/m</p>	<p>1683 0.815 kg/m</p>	<p>1767 0.263 kg/m</p>
<p>1764 0.312 kg/m</p>	<p>1755 0.234 kg/m</p>	<p>4242 0.094 kg/m</p>	<p>7021 0.140 kg/m</p>
<p>1775 1.525 kg/m</p>	<p>1904 1.337 kg/m</p> <p><small>1783 ve 1785 için Çavuş Bağlantı</small></p>	<p>2052 1.724 kg/m</p>	

55-1700-1701

1.344 kg/m

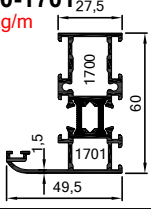

55-1702-1703

1.524 kg/m

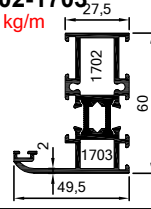

55-1704-1705

1.582 kg/m

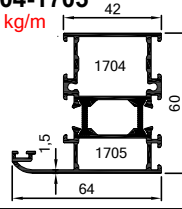

55-1706-1707

1.849 kg/m

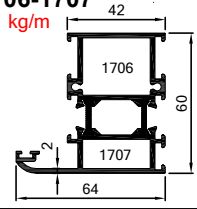

55-5551-5554

1.342 kg/m

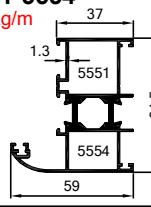

55-5553-5555

1.633 kg/m

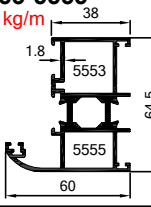

55-1700-1768

1.262 kg/m

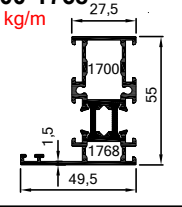

55-1702-1770

1.421 kg/m

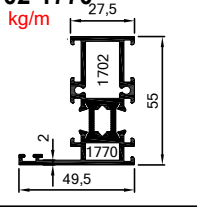

55-1934-1935

1.103 kg/m

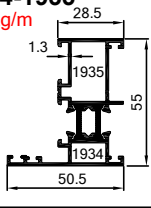

55-1936-1937

1.182 kg/m

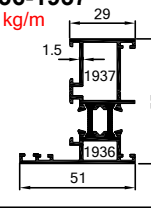

55-1974-1975

1.317 kg/m

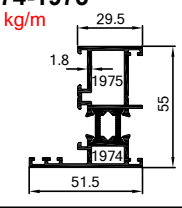

55-5550-5551

1.240 kg/m

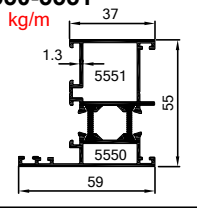

55-1938-1939

1.325 kg/m

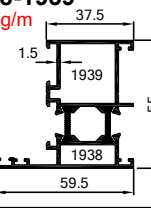

55-5552-5553

1.485 kg/m

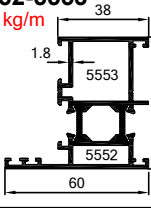

55-1706-1771

1.737 kg/m

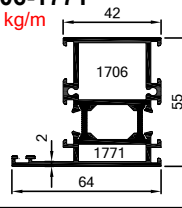

55-1704-1769

1.502 kg/m

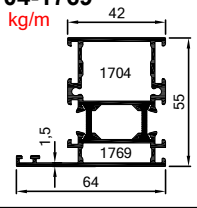

55-1970-1971

1.323 kg/m

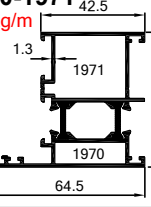

55-1972-1973

1.419 kg/m

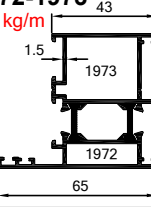

55-3548-3549

1.661 kg/m

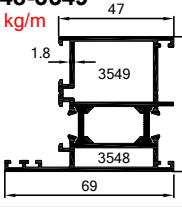

55-1932-1933

1.478 kg/m

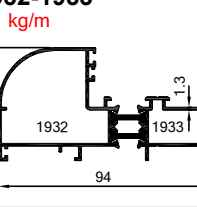

55-1771-2288

2.057 kg/m

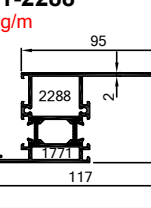

55-1707-2288

2.165 kg/m

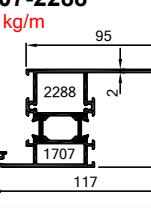

55-7110-7111

1.754 kg/m

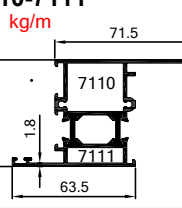

55-1769-5393

1.660 kg/m

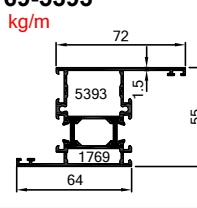

55-1705-5393

1.741 kg/m

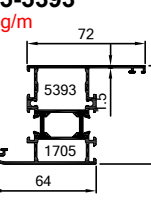

55-5152-5153

1.564 kg/m

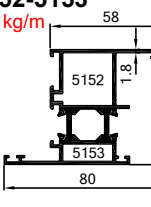

55-5159-5153

1.714 kg/m

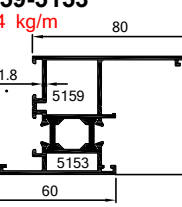

55-1708-1709

1.345 kg/m

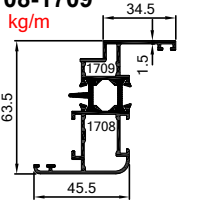

55-6502-6503

1.469 kg/m

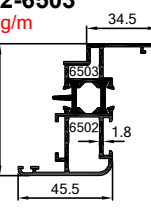

55-1710-1711

1.569 kg/m

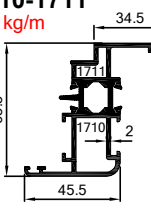

55-3550-3551

1.215 kg/m

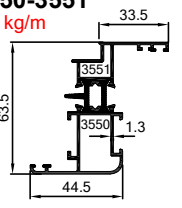

55-3558-3559

1.310 kg/m

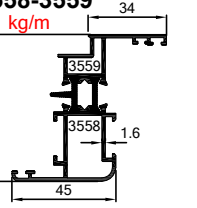

55-3560-3561

1.473 kg/m

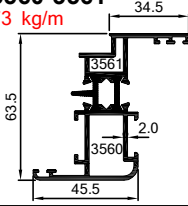

55-5556-5557

1.360 kg/m

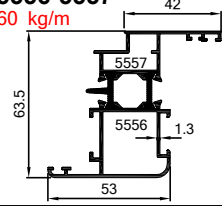

55-3562-3563

1.451 kg/m

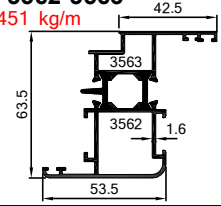

55-5558-5559

1.660 kg/m

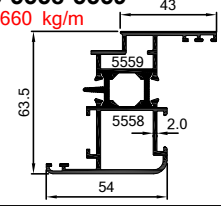

55-6504-6505

1.615 kg/m

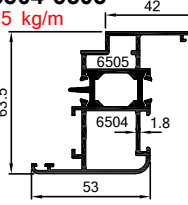

55-3554-3555

1.443 kg/m

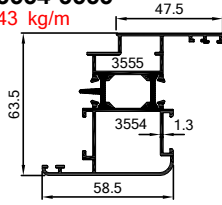

55-3564-3565

1.540 kg/m

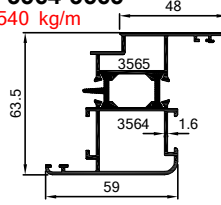

55-3566-3567

1.767 kg/m

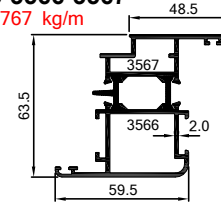

55-3552-3553

1.230 kg/m

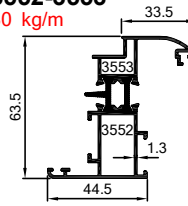

55-5560-5561

1.376 kg/m

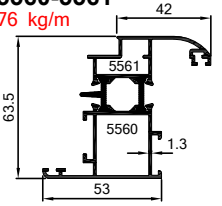

55-3556-3557

1.459 kg/m

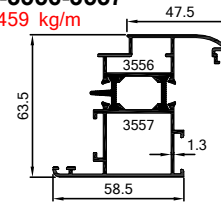

55-5571-5572

1.430 kg/m

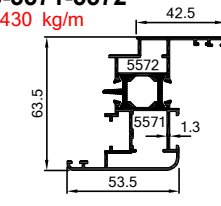

55-5569-5573

1.450 kg/m

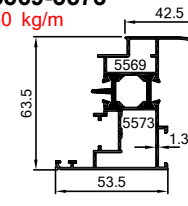

55-5569-5570

1.643 kg/m

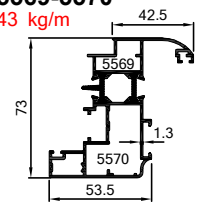

55-5568-5569

1.647 kg/m

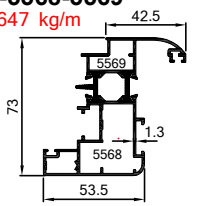

55-1642-1643

1.550 kg/m

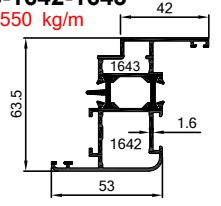

55-3944-3945

1.760 kg/m

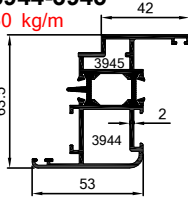

55-1712-1713

1.589 kg/m

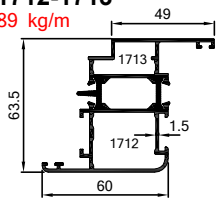

55-1714-1715

1.884 kg/m

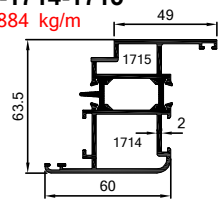

55-5150-5151

1.641 kg/m

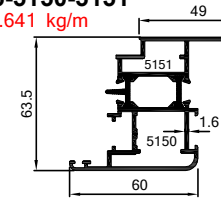

55-5588-5589

1.719 kg/m

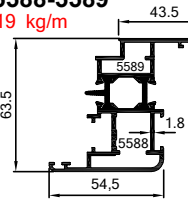

55-1724-1725

2.515 kg/m

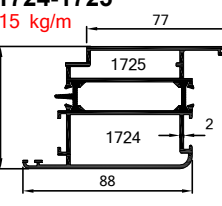

55-1950-1951

2.632 kg/m

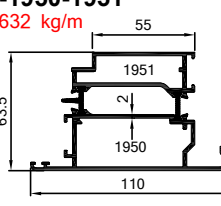

55-3570-3571

2.357 kg/m

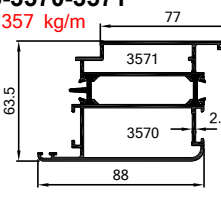

55-3568-3569

2.100 kg/m

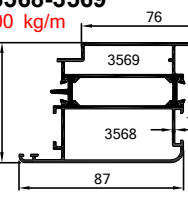

55-4303-4304

2.080 kg/m

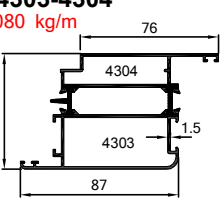

55-5576-5577

2.077 kg/m

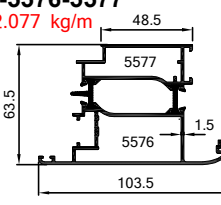

55-3572-3573

2.115 kg/m

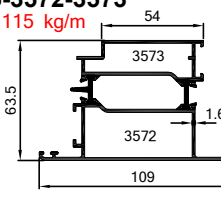

55-4359-4360

2.133 kg/m

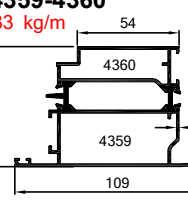

55-3574-3575

2.380 kg/m

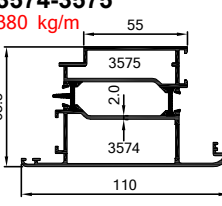

55-5574-5575

2.055 kg/m

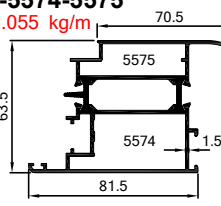

55-5585-5586

2.032 kg/m

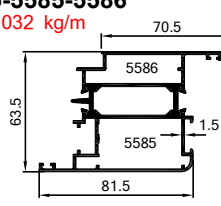

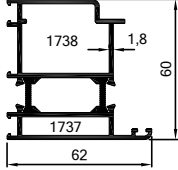
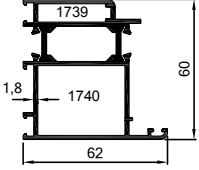
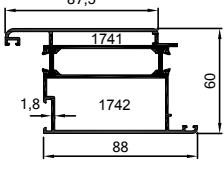
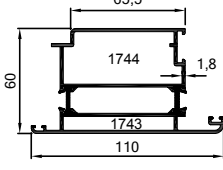
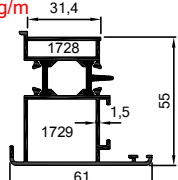
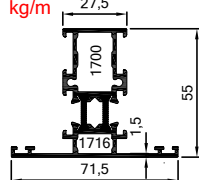
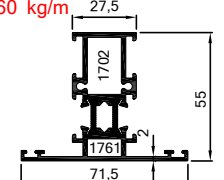
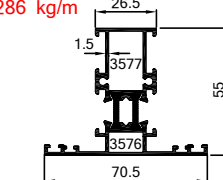
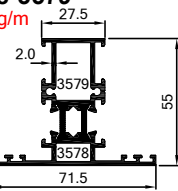
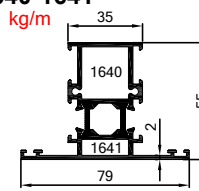
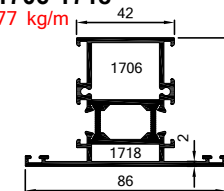
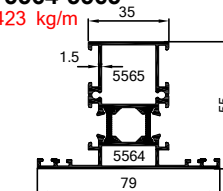
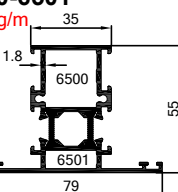
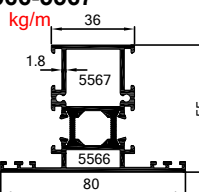
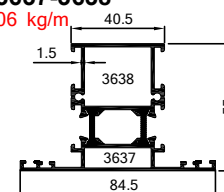
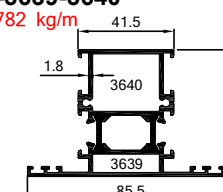
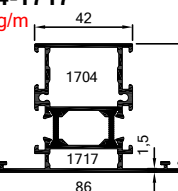
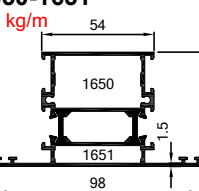
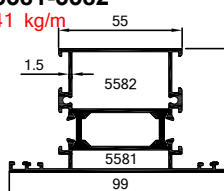
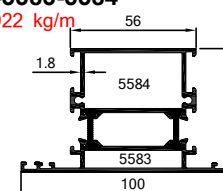
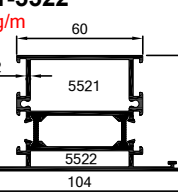
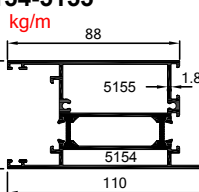
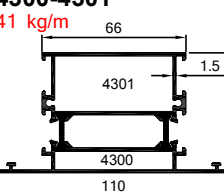
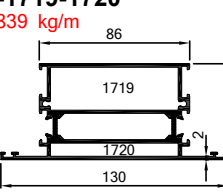
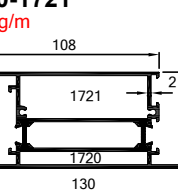
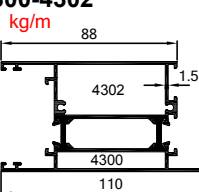
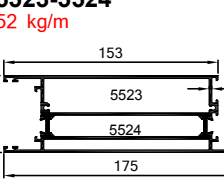
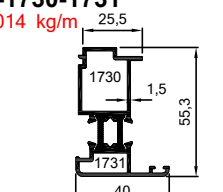
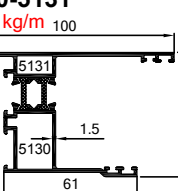
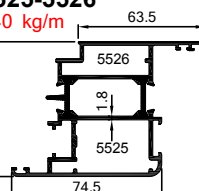
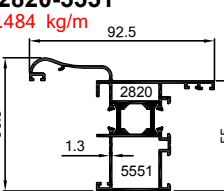
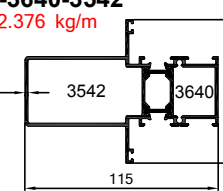
55-1737-1738 1.652 kg/m 	55-1739-1740 1.661 kg/m 	55-1741-1742 2.343 kg/m 	55-1743-1744 2.351 kg/m 
55-1728-1729 1.321 kg/m 	55-1700-1716 1.377 kg/m 	55-1702-1761 1.560 kg/m 	55-3576-3577 1.286 kg/m 
55-3578-3579 1.518 kg/m 	55-1640-1641 1.735 kg/m 	55-1706-1718 1.877 kg/m 	55-5564-5565 1.423 kg/m 
55-6500-6501 1.644 kg/m 	55-5566-5567 1.687 kg/m 	55-3637-3638 1.506 kg/m 	55-3639-3640 1.782 kg/m 
55-1704-1717 1.615 kg/m 	55-1650-1651 1.811 kg/m 	55-5581-5582 1.841 kg/m 	55-5583-5584 2.022 kg/m 
55-5521-5522 2.272 kg/m 	55-5154-5155 2.370 kg/m 	55-4300-4301 2.041 kg/m 	55-1719-1720 2.839 kg/m 
55-1720-1721 2.977 kg/m 	55-4300-4302 2.163 kg/m 	55-5523-5524 3.952 kg/m 	55-1730-1731 1.014 kg/m 
55-5130-5131 1.619 kg/m 	55-5525-5526 2.140 kg/m 	55-2820-5551 1.484 kg/m 	55-3640-3542 2.376 kg/m 

55-1732-1733

1.019 kg/m

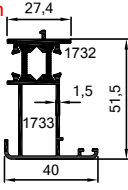

55-1762-1763

1.132 kg/m

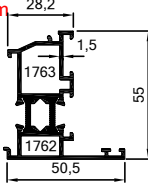

55-1734-1735

1.465 kg/m

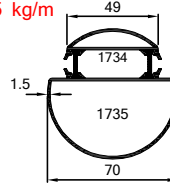

55-1952-1953

1.391 kg/m

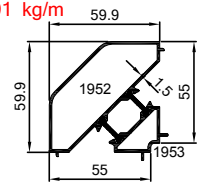

55-5578-5579

1.243 kg/m

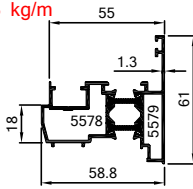

55-1726-1727

1.337 kg/m

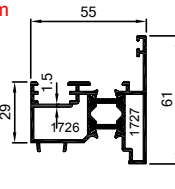

1736

0.222 kg/m

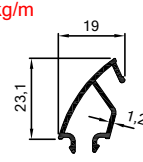

7021

0.140 kg/m

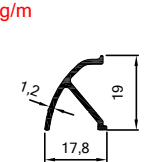

4242

0.094 kg/m

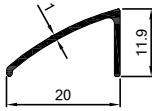

1772

0.176 kg/m

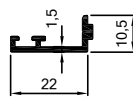

1011

0.402 kg/m

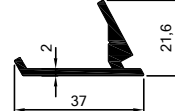

1764

0.312 kg/m

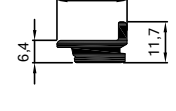

8241

0.099 kg/m

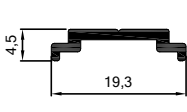

1755

0.234 kg/m

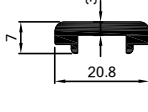

1766

1.352 kg/m

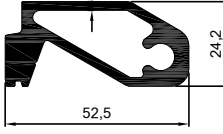

1773

0.985 kg/m

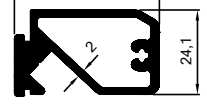

1765

0.385 kg/m

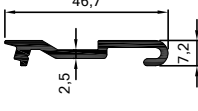

1774

0.480 kg/m

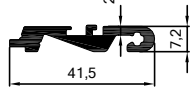

1767

0.263 kg/m

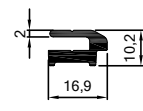

1722

0.623 kg/m

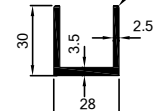

1704,1706,1717,1718,1783 ve 2096 nolu profiller ile çalışır

1911

0.425 kg/m

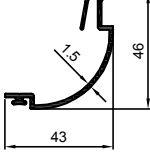

2052

1.724 kg/m

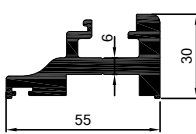

1662

2.591 kg/m

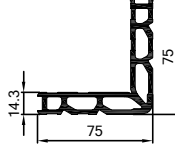

(1756 nin ekonomik olani)

1695

2.602 kg/m

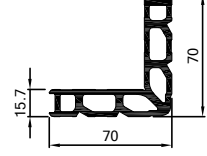

1661

3.688 kg/m

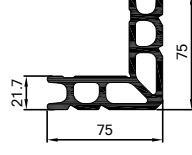

1640,1641,1642,1643 nolu profillerin köşe takozu

3546

3.357 kg/m

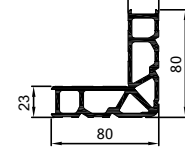

1663

3.578 kg/m

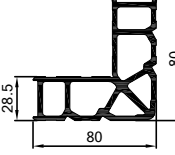

(1757 nin ekonomik olani)

7022

3.592 kg/m

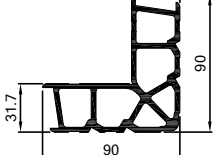

1664

4.127 kg/m

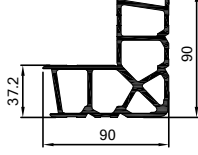

(1758 in ekonomik olani)

3698

4.604 kg/m

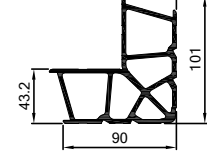

3547

4.954 kg/m

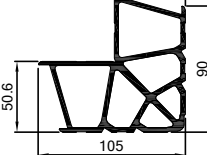

1398

5.089 kg/m

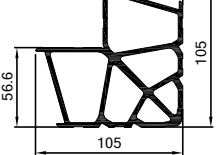

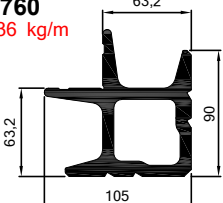
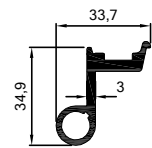
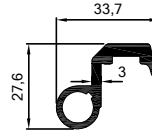
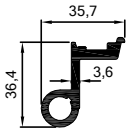
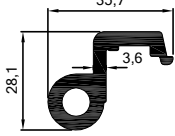
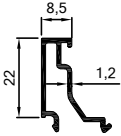
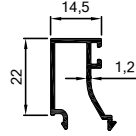
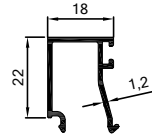
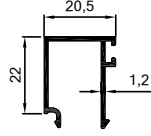
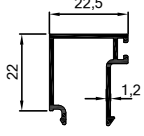
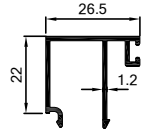
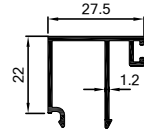
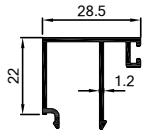
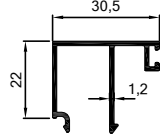
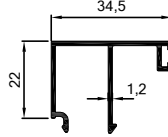
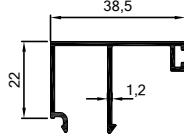
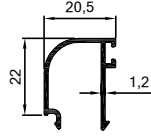
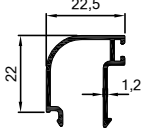
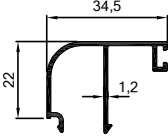
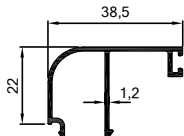
1760 8.436 kg/m 	1752 0.640 kg/m 	1753 0.565 kg/m 	1682 0.811 kg/m 
1683 0.815 kg/m 	1948 0.239 kg/m 	1698 0.256 kg/m 	3539 0.260 kg/m 
1699 0.268 kg/m 	1745 0.279 kg/m 	1949 0.313 kg/m 	2236 0.316 kg/m 
1966 0.320 kg/m 	3636 0.327 kg/m 	1747 0.341 kg/m 	1749 0.355 kg/m 
5546 0.255 kg/m 	1746 0.266 kg/m 	1748 0.327 kg/m 	1750 0.341 kg/m 

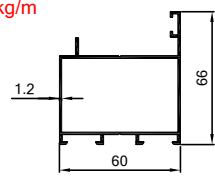
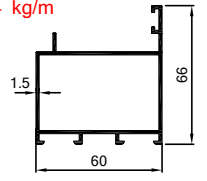
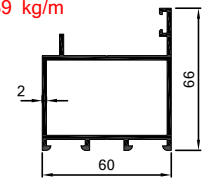
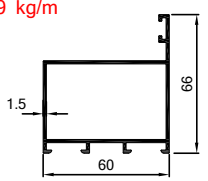
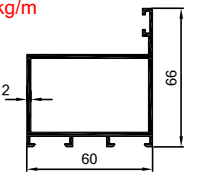
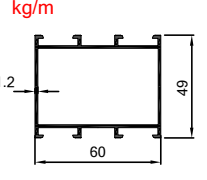
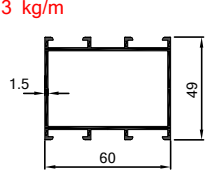
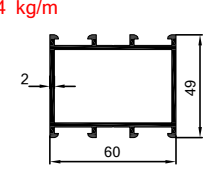
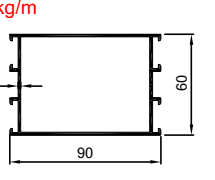
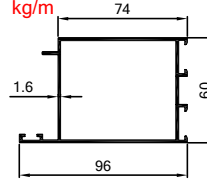
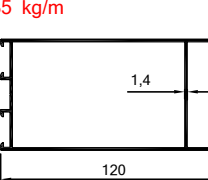
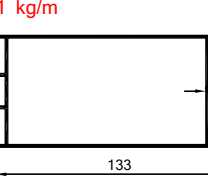
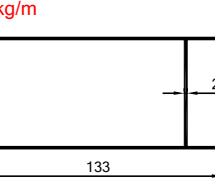
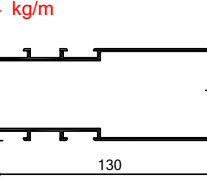
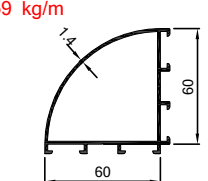
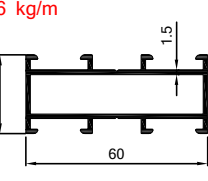
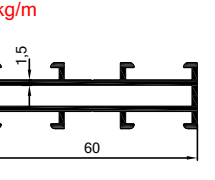
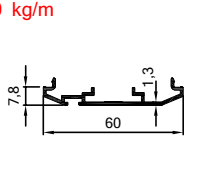
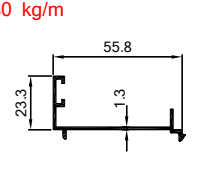
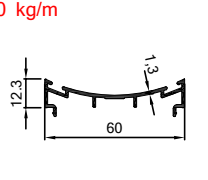
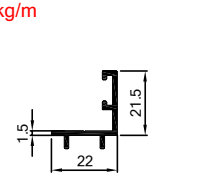
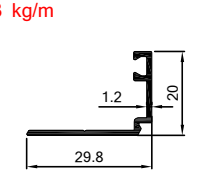
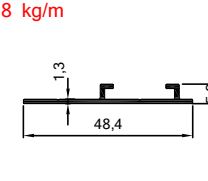
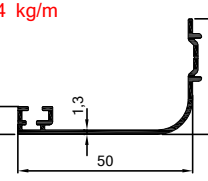
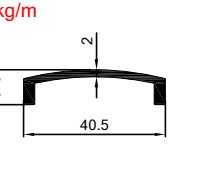
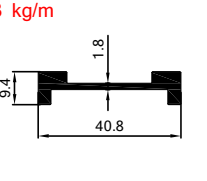
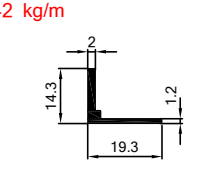
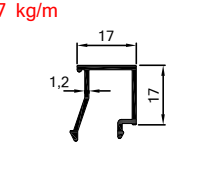
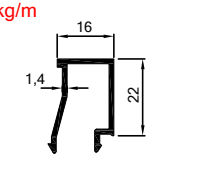
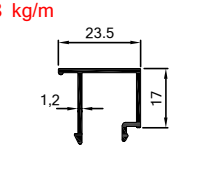
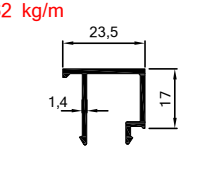
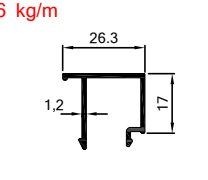
6080 0.888 kg/m 	451 1.064 kg/m 	2020 1.339 kg/m 	522 1.029 kg/m 
521 1.290 kg/m 	569 0.861 kg/m 	452 1.013 kg/m 	2021 1.264 kg/m 
457 1.419 kg/m 	475 1.381 kg/m 	7396 1.435 kg/m 	518 1.621 kg/m 
456 2.112 kg/m 	705 1.914 kg/m 	453 1.059 kg/m 	530 0.826 kg/m 
478 0.770 kg/m 	700 0.370 kg/m 	701 0.380 kg/m 	704 0.410 kg/m 
2030 0.247 kg/m 	481 0.183 kg/m 	480 0.218 kg/m 	479 0.364 kg/m 
5673 0.323 kg/m 	5674 0.433 kg/m 	5675 0.142 kg/m 	455 0.207 kg/m 
2023 0.273 kg/m 	454 0.228 kg/m 	2022 0.262 kg/m 	2279 0.236 kg/m 

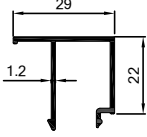
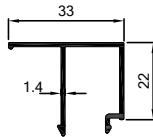
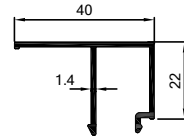
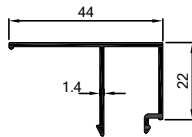
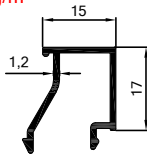
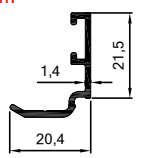
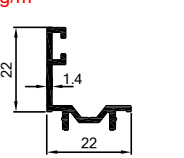
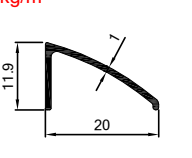
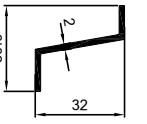
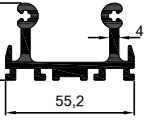
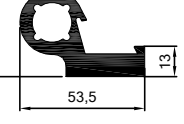
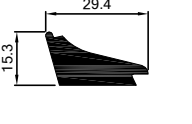
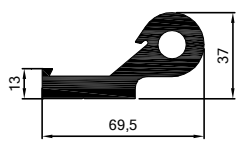
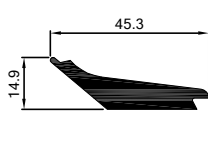
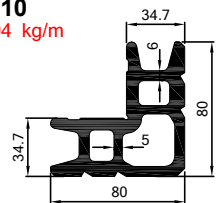
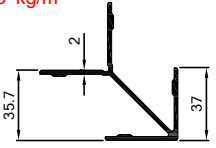
509 0.277 kg/m 	2273 0.336 kg/m 	5786 0.363 kg/m 	2281 0.378 kg/m 
6975 0.203 kg/m 	5601 0.216 kg/m 	510 0.255 kg/m 	4242 0.094 kg/m 
3840 0.299 kg/m 	458 1.508 kg/m 	461 1.922 kg/m 	462 0.638 kg/m 
463 2.701 kg/m 	464 0.754 kg/m 	410 6.094 kg/m 	508 1.105 kg/m  451,452,569ve705no'luprofillerineçavuşbağlantısı

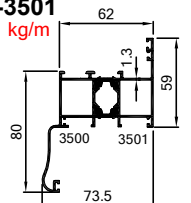
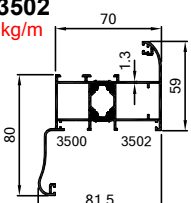
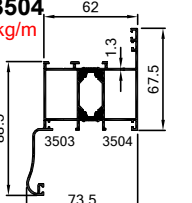
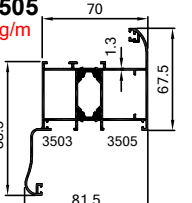
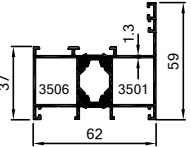
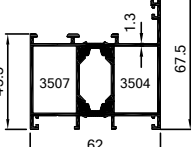
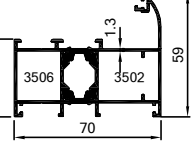
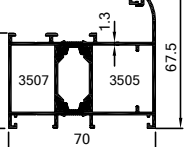
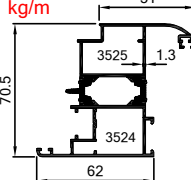
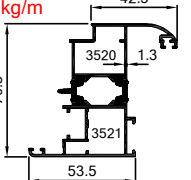
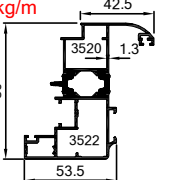
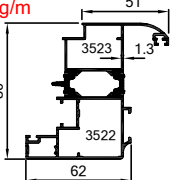
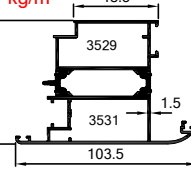
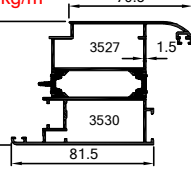
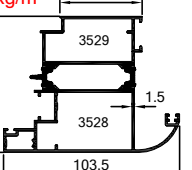
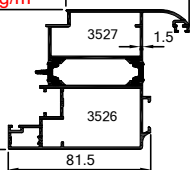
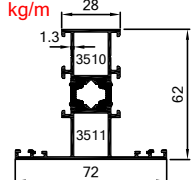
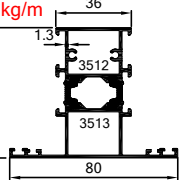
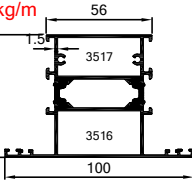
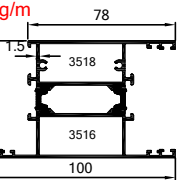
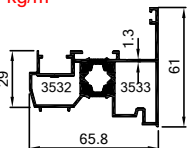
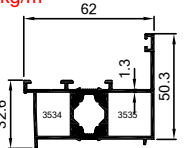
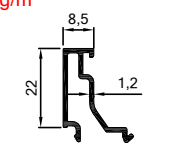
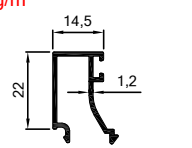
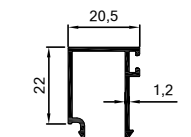
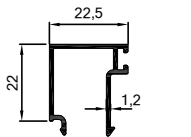
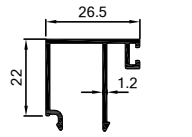
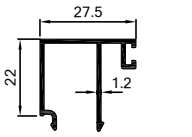
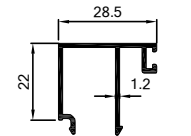
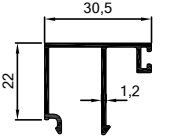
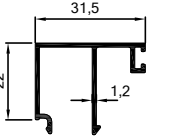
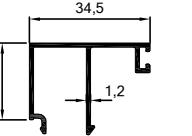
3500-3501 1.562 kg/m 	3500-3502 1.676 kg/m 	3503-3504 1.691 kg/m 	3503-3505 1.805 kg/m 
3506-3501 1.325 kg/m 	3504-3507 1.454 kg/m 	3506-3502 1.439 kg/m 	3505-3507 1.568 kg/m 
3524-3525 1.629 kg/m 	3520-3521 1.504 kg/m 	3519-3520 1.693 kg/m 	3522-3523 1.820 kg/m 
3529-3531 2.132 kg/m 	3527-3530 2.132 kg/m 	3528-3529 2.351 kg/m 	3526-3527 2.335 kg/m 
3510-3511 1.318 kg/m 	3512-3513 1.502 kg/m 	3516-3517 1.953 kg/m 	3516-3518 2.074 kg/m 
3532-3533 1.342 kg/m 	3534-3535 1.165 kg/m 	1948 0.239 kg/m 	1698 0.256 kg/m 
1699 0.268 kg/m 	1745 0.278 kg/m 	1949 0.313 kg/m 	2236 0.316 kg/m 
1966 0.319 kg/m 	3636 0.327 kg/m 	3536 0.331 kg/m 	1747 0.341 kg/m 

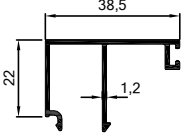
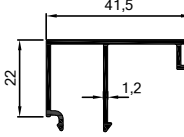
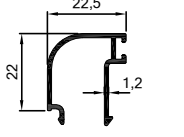
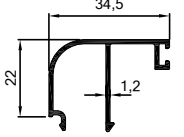
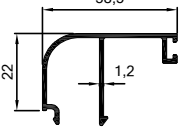
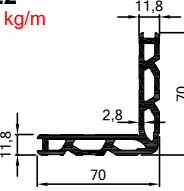
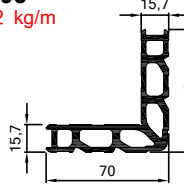
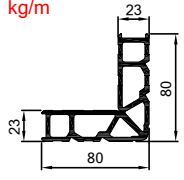
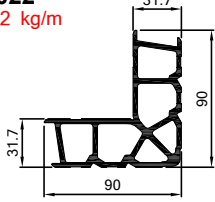
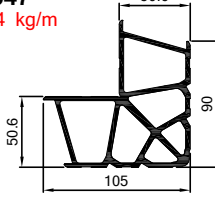
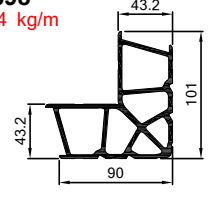
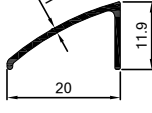
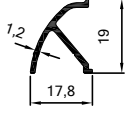
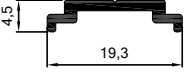
<p>1749 0.355 kg/m</p> 	<p>3537 0.366 kg/m</p> 	<p>1746 0.266 kg/m</p> 	<p>1748 0.327 kg/m</p> 
<p>1750 0.341 kg/m</p> 	<p>5022 2.370 kg/m</p> 	<p>1695 2.602 kg/m</p> 	<p>3546 3.357 kg/m</p> 
<p>7022 3.592 kg/m</p> 	<p>3547 4.954 kg/m</p> 	<p>3698 4.604 kg/m</p> 	<p>4242 0.094 kg/m</p> 
<p>7021 0.140 kg/m</p> 	<p>8241 0.099 kg/m</p> 		

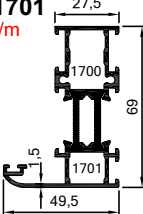
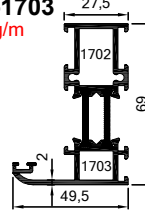
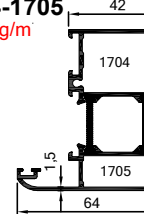
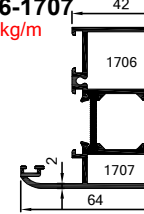
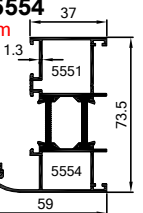
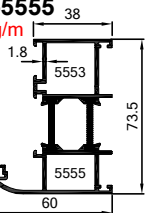
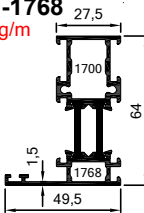
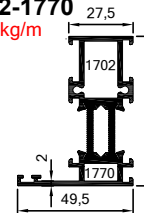
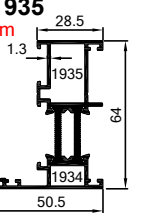
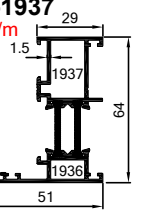
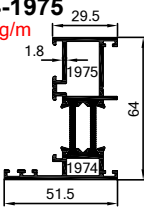
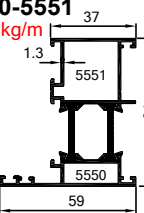
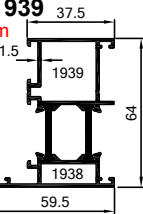
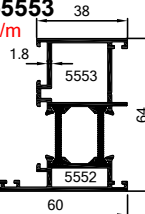
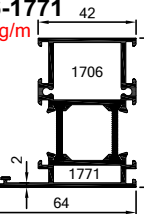
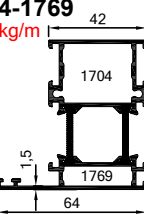
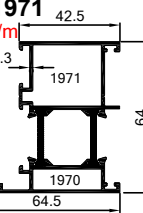
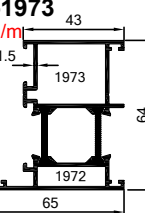
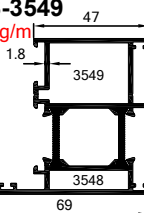
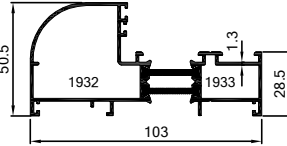
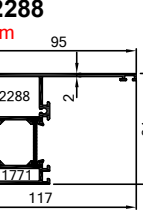
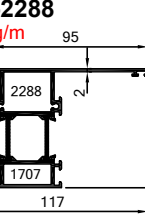
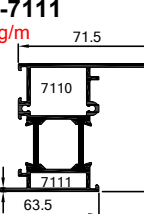
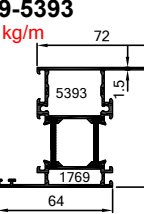
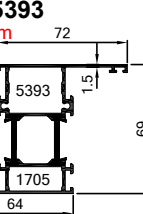
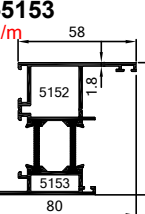
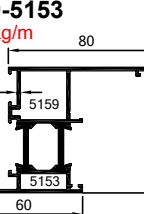
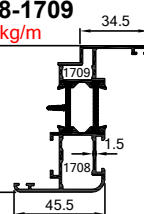
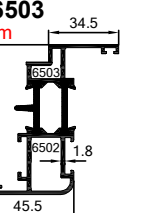
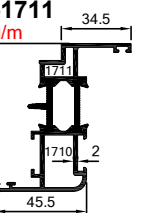
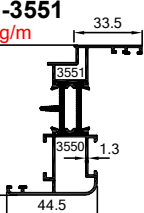
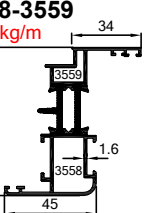
64-1700-1701 1.398 kg/m 	64-1702-1703 1.578 kg/m 	64-1704-1705 1.636 kg/m 	64-1706-1707 1.903 kg/m 
64-5551-5554 1.396 kg/m 	64-5553-5555 1.687 kg/m 	64-1700-1768 1.316 kg/m 	64-1702-1770 1.475 kg/m 
64-1934-1935 1.157 kg/m 	64-1936-1937 1.236 kg/m 	64-1974-1975 1.371 kg/m 	64-5550-5551 1.294 kg/m 
64-1938-1939 1.379 kg/m 	64-5552-5553 1.539 kg/m 	64-1706-1771 1.791 kg/m 	64-1704-1769 1.556 kg/m 
64-1970-1971 1.377 kg/m 	64-1972-1973 1.473 kg/m 	64-3548-3549 1.715 kg/m 	64-1932-1933 1.532 kg/m 
64-1771-2288 2.111 kg/m 	64-1707-2288 2.219 kg/m 	64-7110-7111 1.808 kg/m 	64-1769-5393 1.714 kg/m 
64-1705-5393 1.795 kg/m 	64-5152-5153 1.618 kg/m 	64-5159-5153 1.786 kg/m 	64-1708-1709 1.399 kg/m 
64-6502-6503 1.523 kg/m 	64-1710-1711 1.623 kg/m 	64-3550-3551 1.269 kg/m 	64-3558-3559 1.364 kg/m 

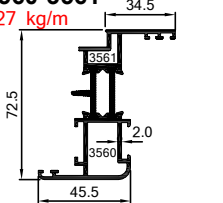
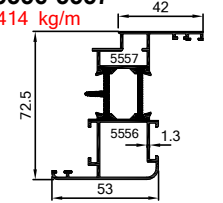
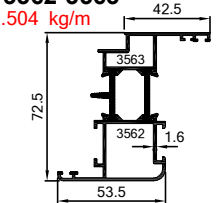
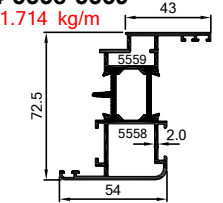
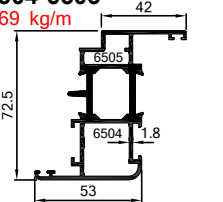
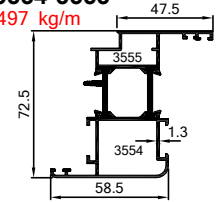
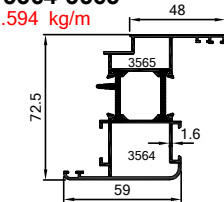
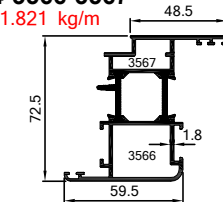
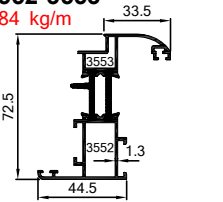
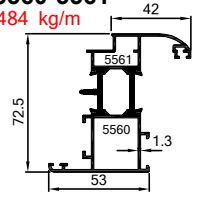
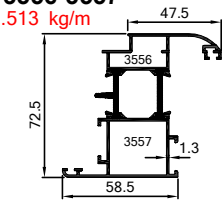
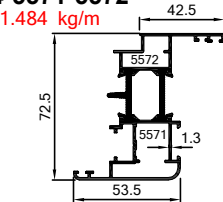
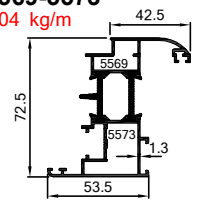
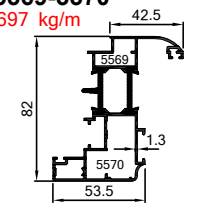
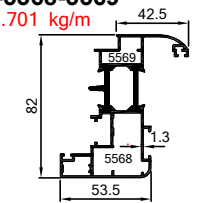
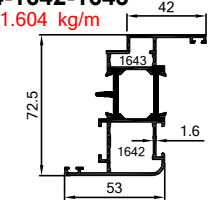
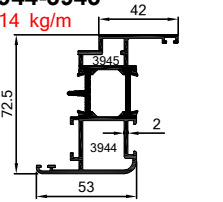
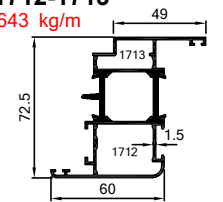
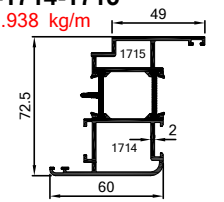
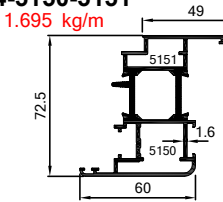
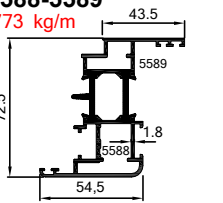
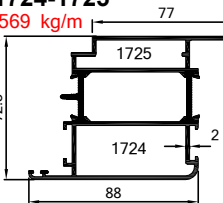
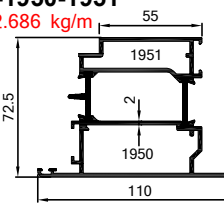
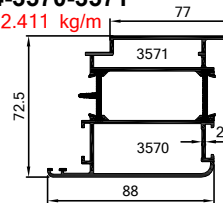
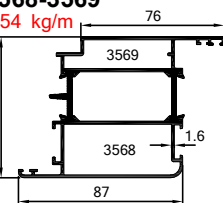
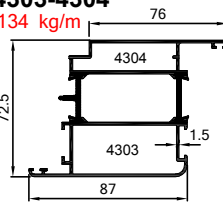
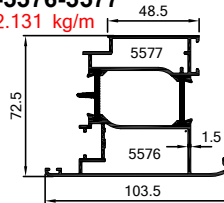
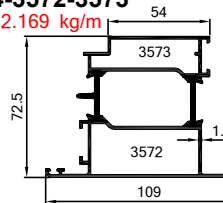
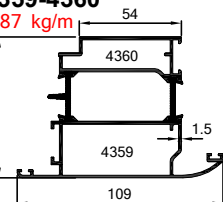
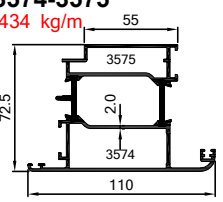
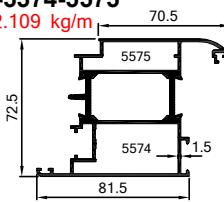
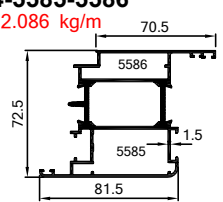
<p>64-3560-3561 1.527 kg/m</p> 	<p>64-5556-5557 1.414 kg/m</p> 	<p>64-3562-3563 1.504 kg/m</p> 	<p>64-5558-5559 1.714 kg/m</p> 
<p>64-6504-6505 1.669 kg/m</p> 	<p>64-3554-3555 1.497 kg/m</p> 	<p>64-3564-3565 1.594 kg/m</p> 	<p>64-3566-3567 1.821 kg/m</p> 
<p>64-3552-3553 1.284 kg/m</p> 	<p>64-5560-5561 1.484 kg/m</p> 	<p>64-3556-3557 1.513 kg/m</p> 	<p>64-5571-5572 1.484 kg/m</p> 
<p>64-5569-5573 1.504 kg/m</p> 	<p>64-5569-5570 1.697 kg/m</p> 	<p>64-5568-5569 1.701 kg/m</p> 	<p>64-1642-1643 1.604 kg/m</p> 
<p>64-3944-3945 1.814 kg/m</p> 	<p>64-1712-1713 1.643 kg/m</p> 	<p>64-1714-1715 1.938 kg/m</p> 	<p>64-5150-5151 1.695 kg/m</p> 
<p>64-5588-5589 1.773 kg/m</p> 	<p>64-1724-1725 2.569 kg/m</p> 	<p>64-1950-1951 2.686 kg/m</p> 	<p>64-3570-3571 2.411 kg/m</p> 
<p>64-3568-3569 2.154 kg/m</p> 	<p>64-4303-4304 2.134 kg/m</p> 	<p>64-5576-5577 2.131 kg/m</p> 	<p>64-3572-3573 2.169 kg/m</p> 
<p>64-4359-4360 2.187 kg/m</p> 	<p>64-3574-3575 2.434 kg/m</p> 	<p>64-5574-5575 2.109 kg/m</p> 	<p>64-5585-5586 2.086 kg/m</p> 

64-1737-1738
1.706 kg/m

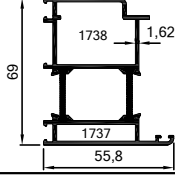

64-1739-1740
1.715 kg/m

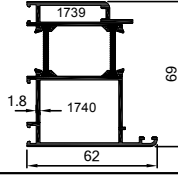

64-1741-1742
2.397 kg/m

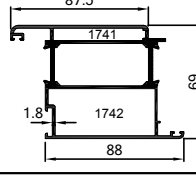

64-1743-1744
2.415 kg/m

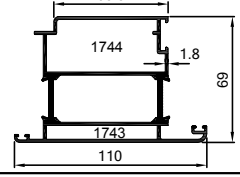

64-1728-1729
1.375 kg/m

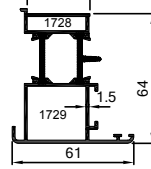

64-1700-1716
1.431 kg/m

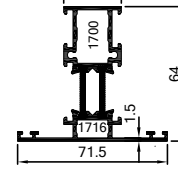

64-1702-1761
1.614 kg/m

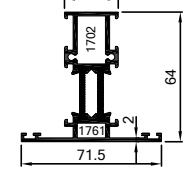

64-3576-3577
1.394 kg/m

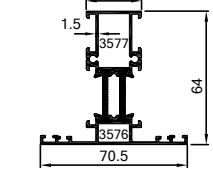

64-3578-3579
1.572 kg/m

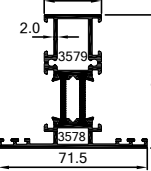

64-1640-1641
1.789 kg/m

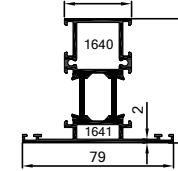

64-1706-1718
1.931 kg/m

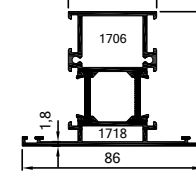

64-5564-5565
1.477 kg/m

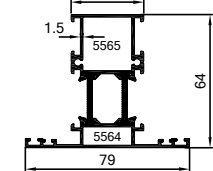

64-6500-6501
1.698 kg/m

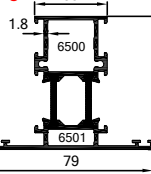

64-5566-5567
1.741 kg/m

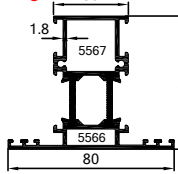

64-3637-3638
1.560 kg/m

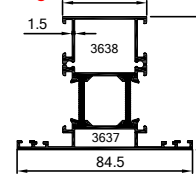

64-3639-3640
1.836 kg/m

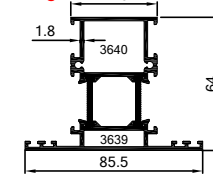

64-1704-1717
1.669 kg/m

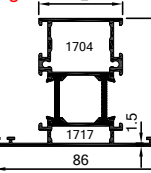

64-1650-1651
1.865 kg/m

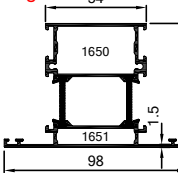

64-5581-5582
1.895 kg/m

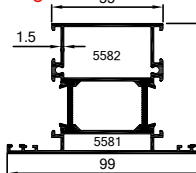

64-5583-5584
2.076 kg/m

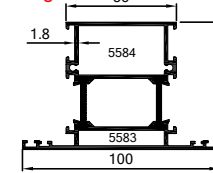

64-5521-5522
2.326 kg/m

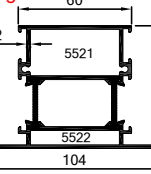

64-5154-5155
2.424 kg/m

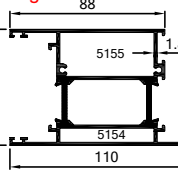

64-4300-4301
2.095 kg/m

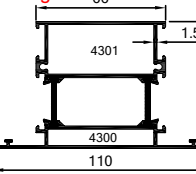

64-1719-1720
2.893 kg/m

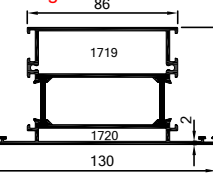

64-1720-1721
3.031 kg/m

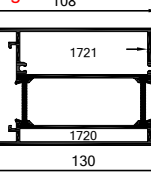

64-4300-4302
2.217 kg/m

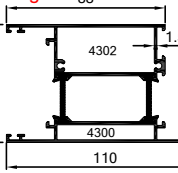

64-5523-5524
4.006 kg/m

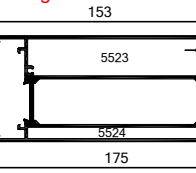

64-1730-1731
1.068 kg/m

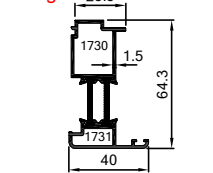

64-5130-5131
1.673 kg/m

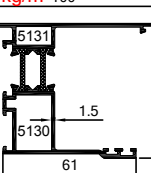

64-5525-5526
2.194 kg/m

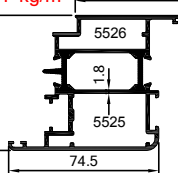

64-2820-5551
1.538 kg/m

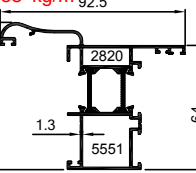

64-3640-3542
2.430 kg/m

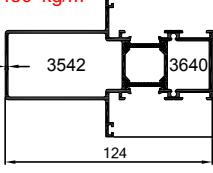

64-1732-1733
1.073 kg/m

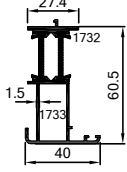

64-1762-1763
1.186 kg/m

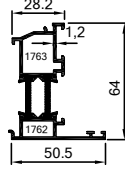

64-1734-3543
1.450 kg/m

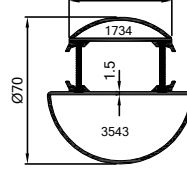

64-5547-1953
1.641 kg/m

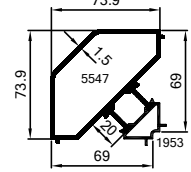

64-5578-5579
1.297 kg/m

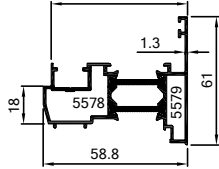

64-1726-1727
1.391 kg/m

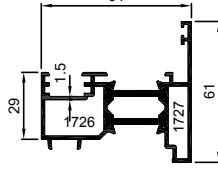

1736
0.222 kg/m

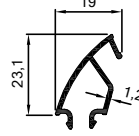

7021
0.140 kg/m

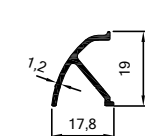

4242
0.094 kg/m

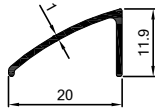

1772
0.176 kg/m

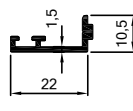

1011
0.402 kg/m

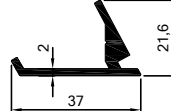

1764
0.312 kg/m

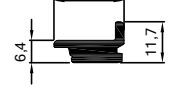

8241
0.099 kg/m

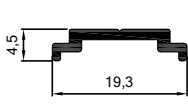

1755
0.234 kg/m

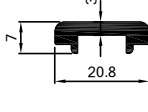

1766
1.352 kg/m

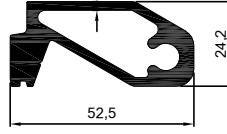

1773
0.985 kg/m

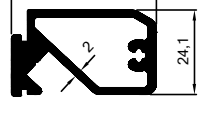

1765
0.385 kg/m

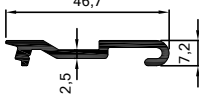

1774
0.480 kg/m

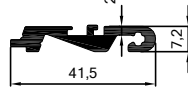

1767
0.263 kg/m

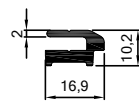

1722
0.623 kg/m

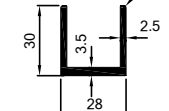

1704,1706,1717,1718,1783 ve 2096 nolu profiller ile çalışır.

3544
0.498 kg/m

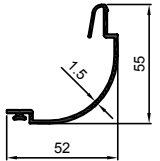

2052
1.724 kg/m

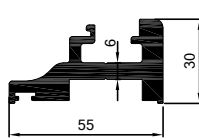

1662
2.591 kg/m

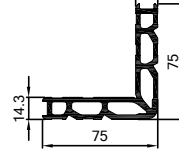

(1756 nin ekonomik olanı)

1695
2.602 kg/m

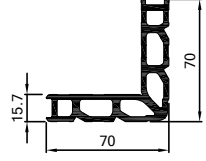

1661
3.688 kg/m

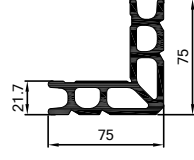

3546
3.357 kg/m

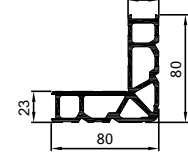

1663
3.578 kg/m

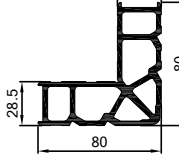

(1757 nin ekonomik olanı)

7022
3.592 kg/m

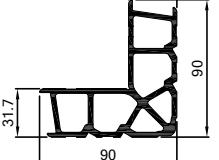

1640,1641,1642,1643 polü profillerin köşe takozu

1664
4.127 kg/m

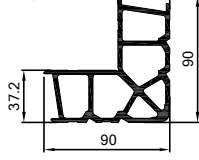

3698
4.604 kg/m

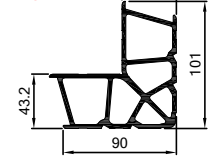

3547
4.954 kg/m

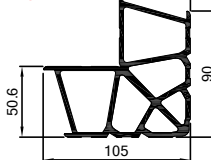

1398
5.089 kg/m

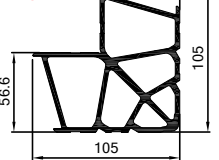

(1758 in ekonomik olanı)

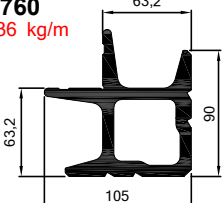
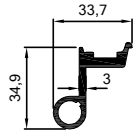
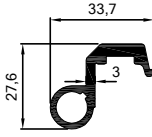
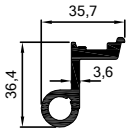
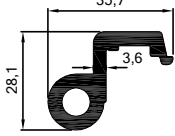
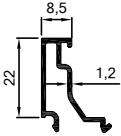
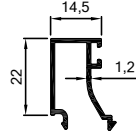
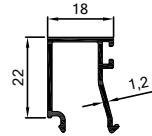
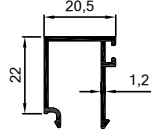
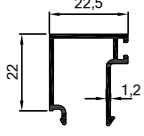
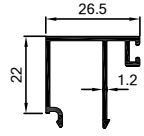
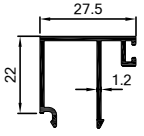
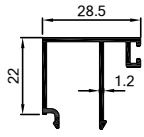
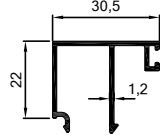
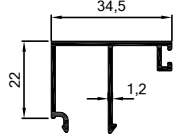
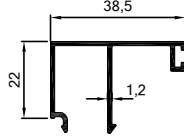
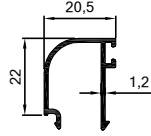
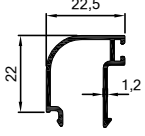
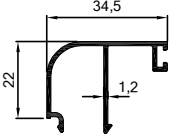
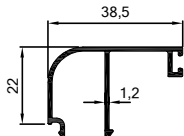
1760 8.436 kg/m 	1752 0.640 kg/m 	1753 0.565 kg/m 	1682 0.811 kg/m 
1683 0.815 kg/m 	1948 0.239 kg/m 	1698 80 0.256 kg/m 	3539 0.260 kg/m 
1699 0.268 kg/m 	1745 0.279 kg/m 	1949 0.313 kg/m 	2236 0.316 kg/m 
1966 0.320 kg/m 	3636 0.327 kg/m 	1747 0.341 kg/m 	1749 0.355 kg/m 
5546 0.255 kg/m 	1746 0.266 kg/m 	1748 0.327 kg/m 	1750 0.341 kg/m 

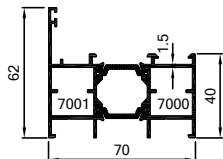
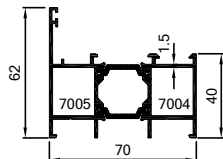
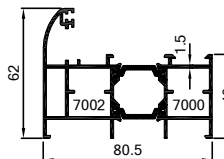
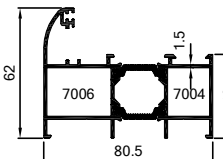
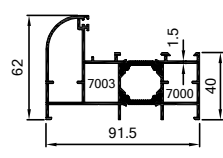
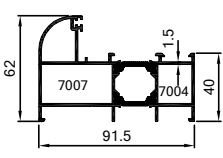
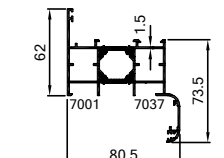
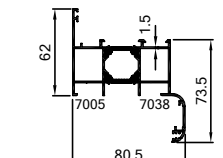
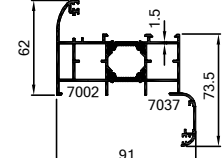
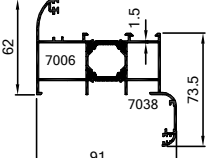
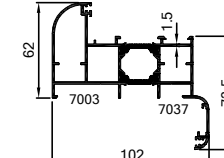
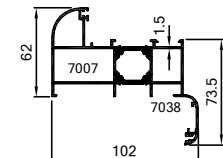
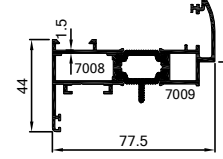
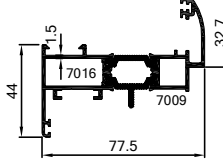
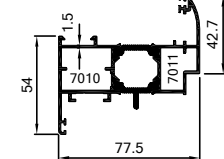
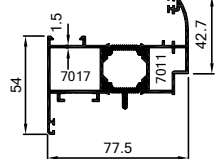
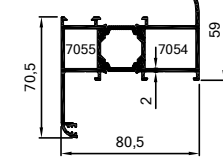
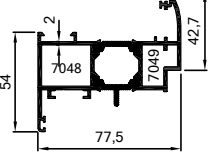
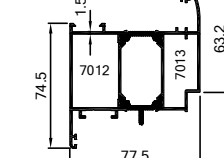
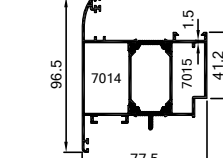
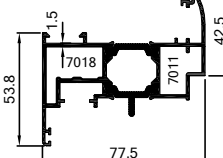
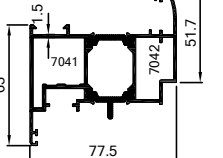
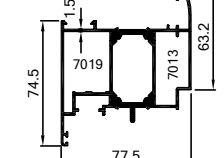
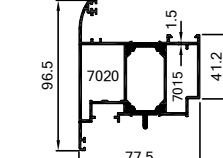
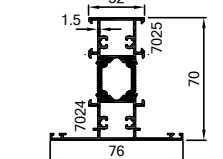
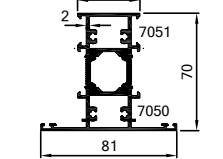
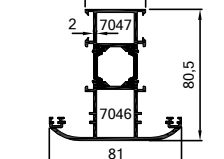
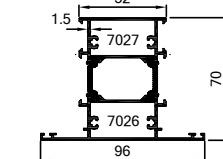
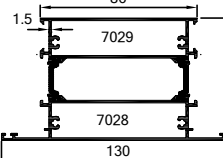
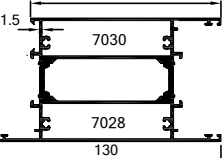
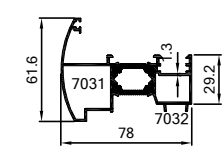
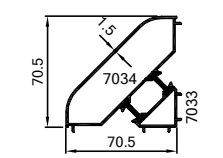
7000-7001 1.515 kg/m 	7004-7005 1.467 kg/m 	7000-7002 1.774 kg/m 	7004-7006 1.515 kg/m 
7000-7003 1.885 kg/m 	7004-7007 1.825 kg/m 	7001-7037 1.786 kg/m 	7005-7038 1.737 kg/m 
7002-7037 2.044 kg/m 	7006-7038 1.902 kg/m 	7003-7037 2.155 kg/m 	7007-7038 2.095 kg/m 
7008-7009 1.456 kg/m 	7009-7016 1.437 kg/m 	7010-7011 1.659 kg/m 	7011-7017 1.627 kg/m 
7054-7055 2.152 kg/m 	7048-7049 1.928 kg/m 	7012-7013 1.974 kg/m 	7014-7015 1.974 kg/m 
7011-7018 1.678 kg/m 	7041-7042 1.834 kg/m 	7013-7019 2.015 kg/m 	7015-7020 2.015 kg/m 
7024-7025 1.664 kg/m 	7050-7051 2.083 kg/m 	7046-7047 2.281 kg/m 	7026-7027 1.989 kg/m 
7028-7029 2.362 kg/m 	7028-7030 2.647 kg/m 	7031-7032 1.392 kg/m 	7033-7034 1.537 kg/m 

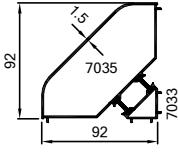
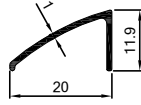
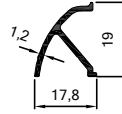
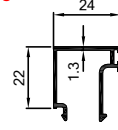
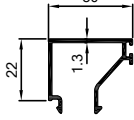
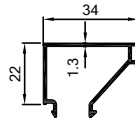
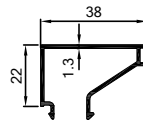
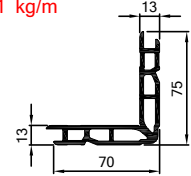
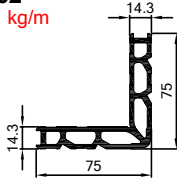
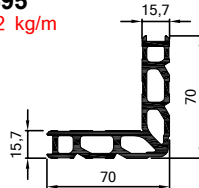
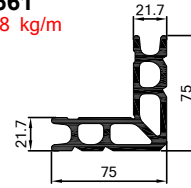
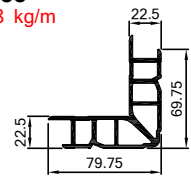
7033-7035
 1.894 kg/m

4242
 0.094 kg/m

7021
 0.140 kg/m

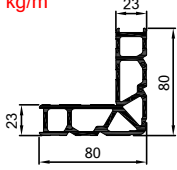
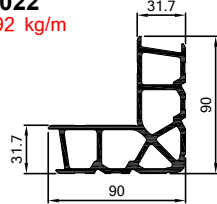
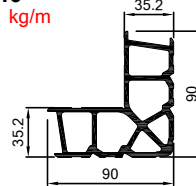
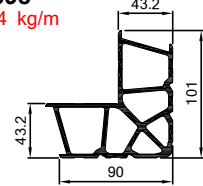
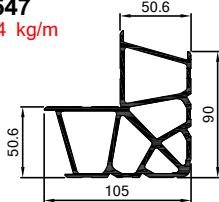
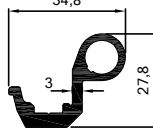
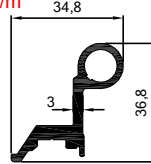
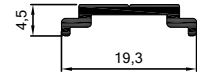
7023
 0.294 kg/m

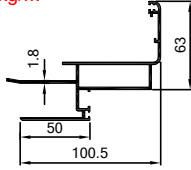
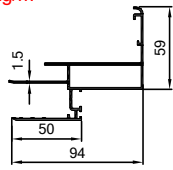
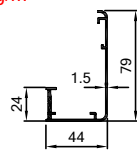
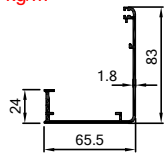
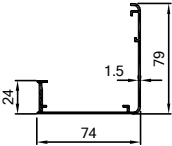
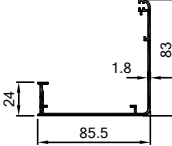
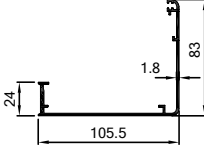
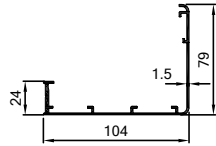
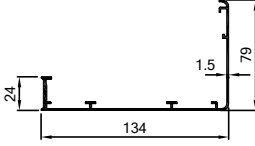
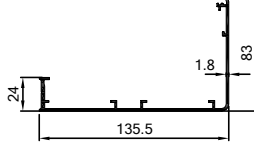
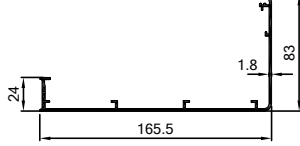
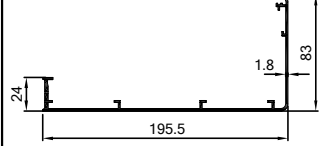
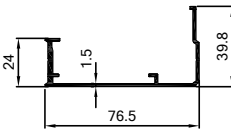
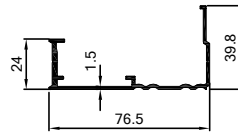
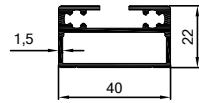
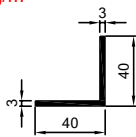
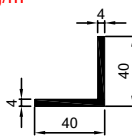
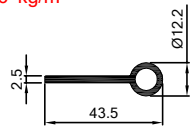
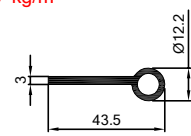
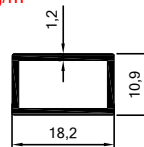
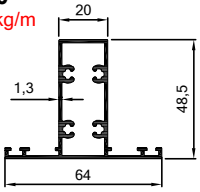
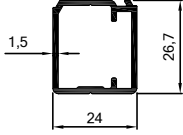
7036
 0.319 kg/m

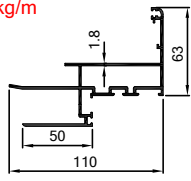
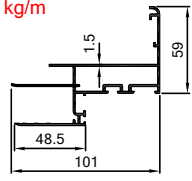
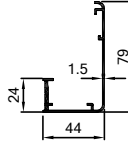
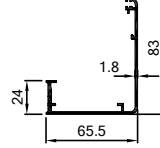
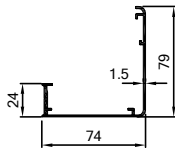
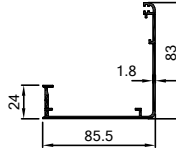
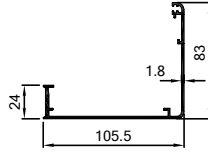
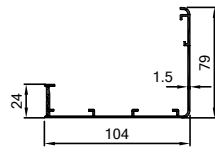
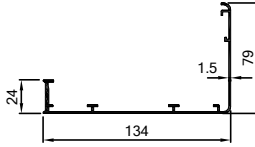
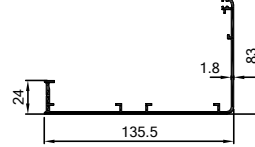
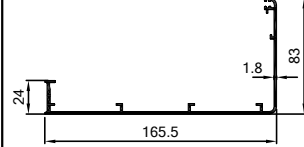
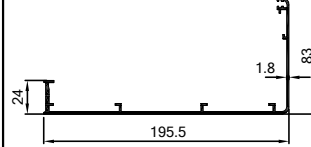
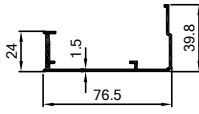
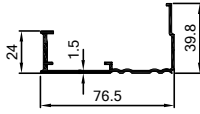
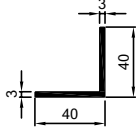
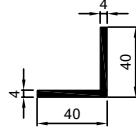
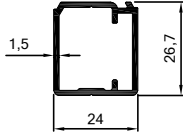
676
 0.338 kg/m

7043
 0.366 kg/m

2371
 2.241 kg/m

1662
 2.591 kg/m

1695
 2.602 kg/m

1661
 3.688 kg/m

3088
 2.608 kg/m

(1756'nin ekonomik olanı)

7046,7047,7048,7049 nolu profillerin köşe takozu

3546
 3.357 kg/m

7022
 3.592 kg/m

7040
 4.067 kg/m

3698
 4.604 kg/m

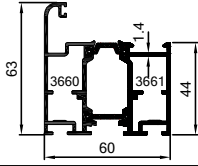
3547
 4.954 kg/m

667
 0.612 kg/m

668
 0.645 kg/m

8241
 0.099 kg/m

2173 1.671 kg/m 	1924 1.372 kg/m 	1925 0.758 kg/m 	2174 0.996 kg/m 
1926 0.880 kg/m 	2175 1.094 kg/m 	2176 1.191 kg/m 	1927 1.064 kg/m 
1928 1.211 kg/m 	2247 1.409 kg/m 	2248 1.555 kg/m 	2249 1.702 kg/m 
1929 0.683 kg/m 	1930 0.688 kg/m 	1931 0.689 kg/m 	3926 0.625 kg/m 
164 0.824 kg/m 	1921 0.386 kg/m 	1976 0.430 kg/m 	4923 0.174 kg/m 
7580 0.907 kg/m 	7696 0.421 kg/m 		

<p>2172 1.841 kg/m</p> 	<p>1923 1.517 kg/m</p> 	<p>1925 0.758 kg/m</p> 	<p>2174 0.996 kg/m</p> 
<p>1926 0.880 kg/m</p> 	<p>2175 1.094 kg/m</p> 	<p>2176 1.191 kg/m</p> 	<p>1927 1.064 kg/m</p> 
<p>1928 1.211 kg/m</p> 	<p>2247 1.409 kg/m</p> 	<p>2248 1.555 kg/m</p> 	<p>2249 1.702 kg/m</p> 
<p>1929 0.683 kg/m</p> 	<p>1930 0.688 kg/m</p> 	<p>3926 0.625 kg/m</p> 	<p>164 0.824 kg/m</p> 
<p>7696 0.421 kg/m</p> 			

3660-3661
1.757 kg/m



3662-3662
1.402 kg/m

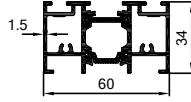

3663-3664
2.519 kg/m

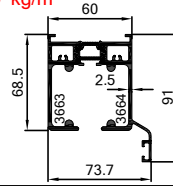

3665-3665
1.108 kg/m

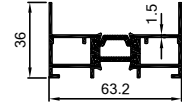

3666-3667
1.345 kg/m

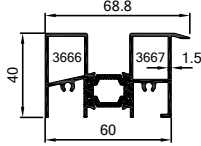

3668
0.237 kg/m

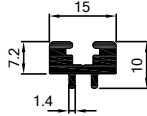

3669
0.199 kg/m

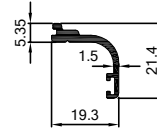

3695
0.244 kg/m

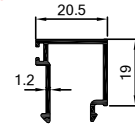

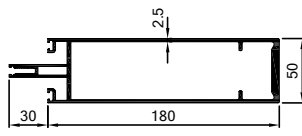
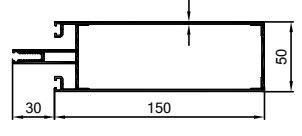
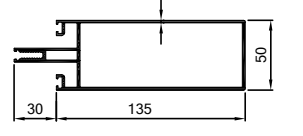
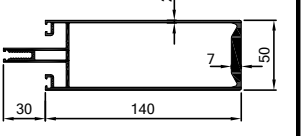
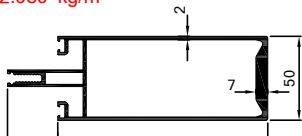
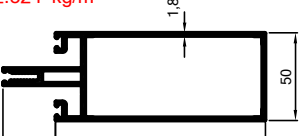
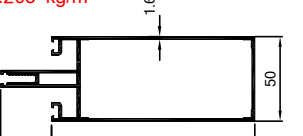
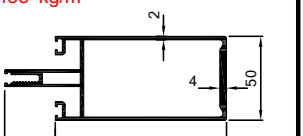
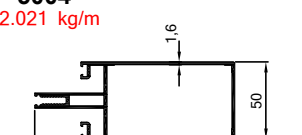
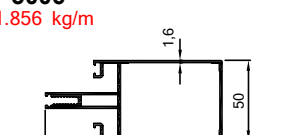
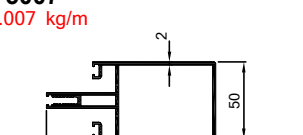
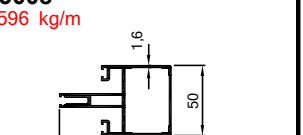
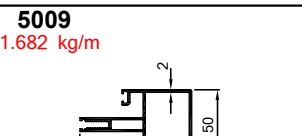
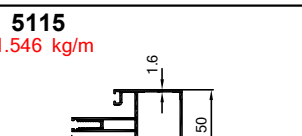
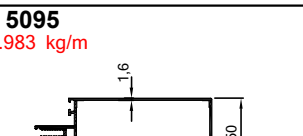
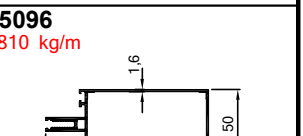
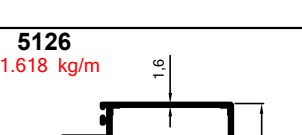
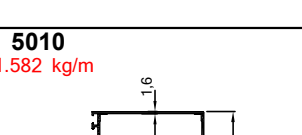
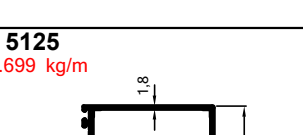
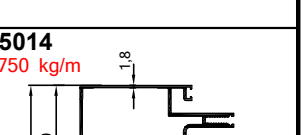
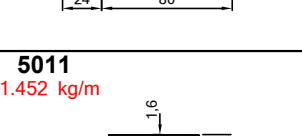
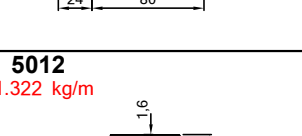
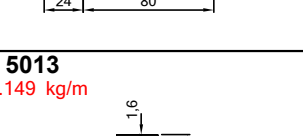
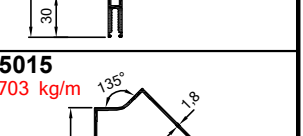
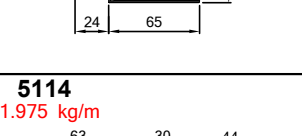
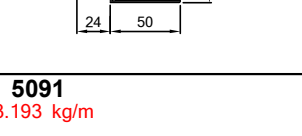
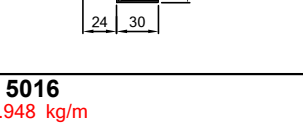
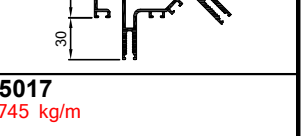
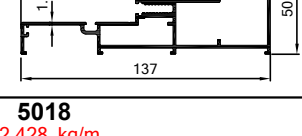
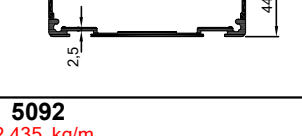
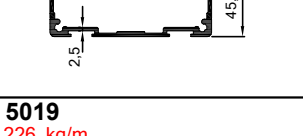
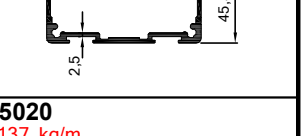
5090 4.211 kg/m 	5078 2.705 kg/m 	5000 2.603 kg/m 	5001 3.151 kg/m 
5003 2.989 kg/m 	7901 2.324 kg/m 	5002 2.205 kg/m 	5005 2.453 kg/m 
5004 2.021 kg/m 	5006 1.856 kg/m 	5007 2.007 kg/m 	5008 1.596 kg/m 
5009 1.682 kg/m 	5115 1.546 kg/m 	5095 1.983 kg/m 	5096 1.810 kg/m 
5126 1.618 kg/m 	5010 1.582 kg/m 	5125 1.699 kg/m 	5014 2.750 kg/m 
5011 1.452 kg/m 	5012 1.322 kg/m 	5013 1.149 kg/m 	5015 2.703 kg/m 
5114 1.975 kg/m 	5091 3.193 kg/m 	5016 2.948 kg/m 	5017 2.745 kg/m 
5018 2.428 kg/m 	5092 2.435 kg/m 	5019 2.226 kg/m 	5020 2.137 kg/m 

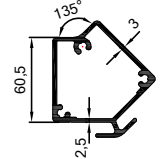
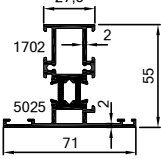
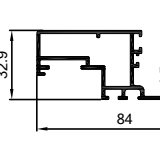
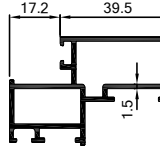
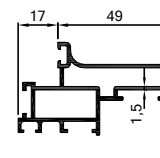
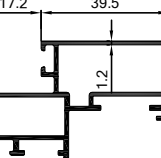
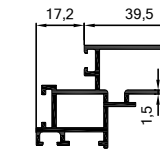
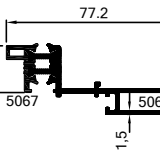
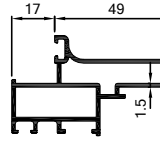
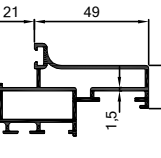
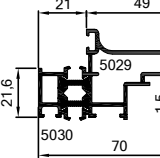
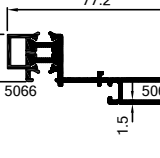
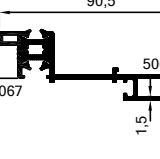
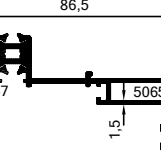
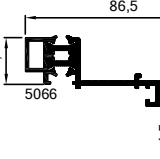
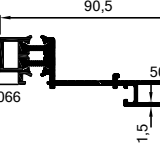
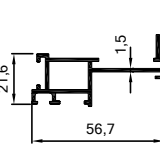
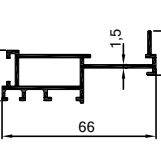
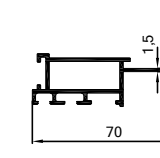
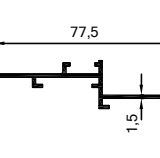
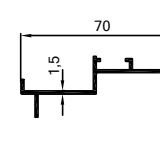
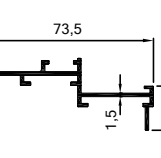
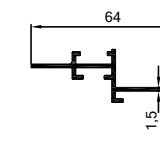
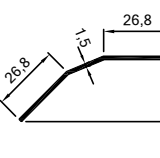
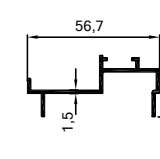
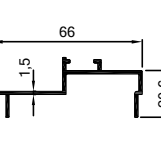
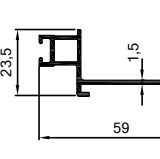
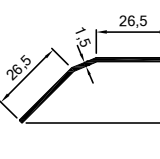
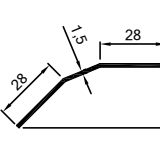
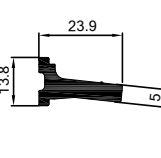
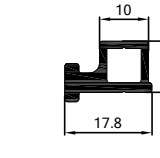
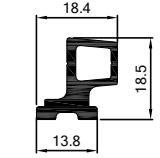
5021 2.467 kg/m 	1702-5025 1.537 kg/m 	5117 1.014 kg/m 	5081 0.908 kg/m 
5028 1.037 kg/m 	5093 0.766 kg/m 	5062 0.918 kg/m 	5064-5067 1.147 kg/m 
5088 1.027 kg/m 	5031 1.093 kg/m 	5029-5030-12 1.262 kg/m 	5064-5066 1.182 kg/m 
5063-5067 1.212 kg/m 	5065-5067 1.193 kg/m 	5065-5066 1.228 kg/m 	5063-5066 1.247 kg/m 
5068 0.638 kg/m 	5032 0.731 kg/m 	5071 0.786 kg/m 	5075 0.573 kg/m 
5072 0.524 kg/m 	5074 0.556 kg/m 	5035 0.518 kg/m 	5039 0.280 kg/m 
5069 0.470 kg/m 	5033 0.508 kg/m 	5056 0.478 kg/m 	5070 0.251 kg/m 
5073 0.294 kg/m 	5079 0.404 kg/m 	5116 0.265 kg/m 	5094 0.340 kg/m 

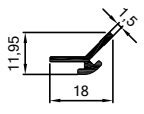
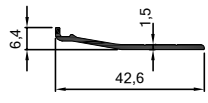
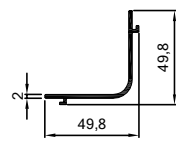
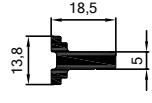
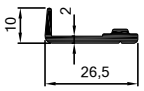
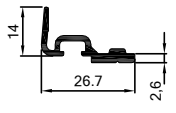
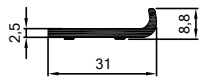
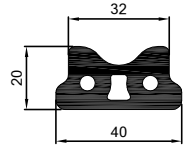
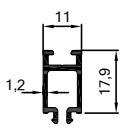
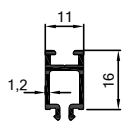
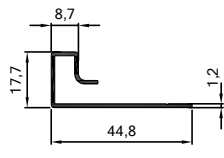
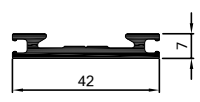
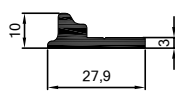
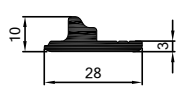
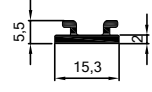
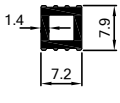
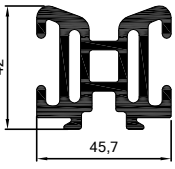
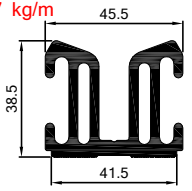
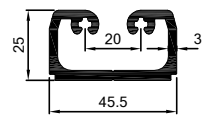
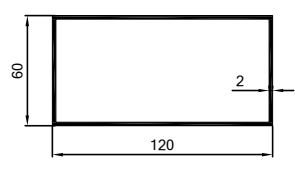
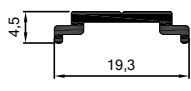
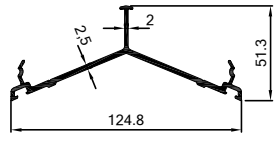
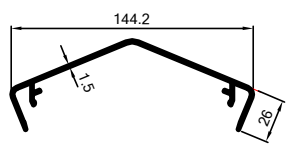
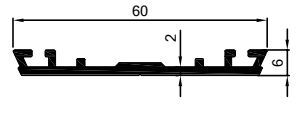
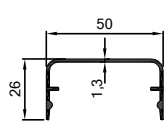
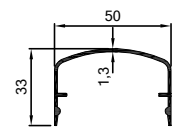
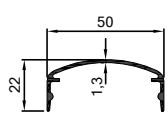
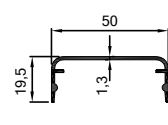
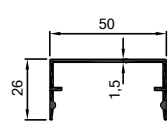
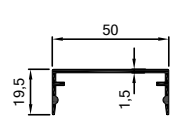
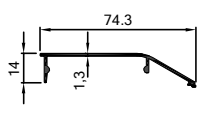
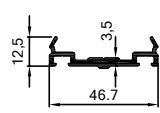
5077 0.126 kg/m 	5060 0.172 kg/m 	5076 0.515 kg/m 	5024 0.323 kg/m 
5026 0.206 kg/m 	5057 0.248 kg/m 	5058 0.244 kg/m 	5038 1.463 kg/m 
5059 0.210 kg/m 	5097 0.198 kg/m 	5034 0.268 kg/m 	5040 0.456 kg/m 
5036 0.339 kg/m 	5037 0.340 kg/m 	5027 0.128 kg/m 	5023 0.094 kg/m 
5041 2.211 kg/m 	6121 2.027 kg/m 	5042 1.144 kg/m 	419 1.908 kg/m 
8241 0.099 kg/m 	5044 1.260 kg/m 	5043 0.961 kg/m 	2019 0.460 kg/m 
5045 0.380 kg/m 	2050 0.403 kg/m 	2049 0.331 kg/m 	5046 0.334 kg/m 
2009 0.439 kg/m 	2006 0.385 kg/m 	5047 0.369 kg/m 	5048 0.466 kg/m 

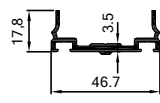
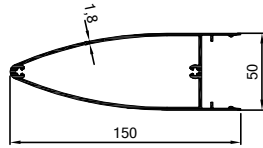
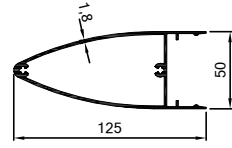
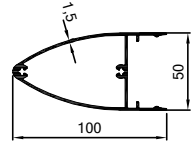
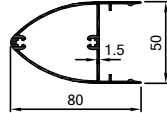
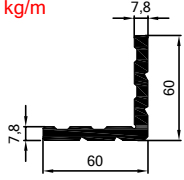
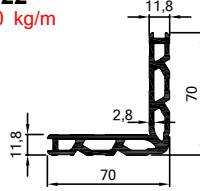
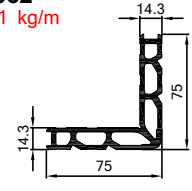
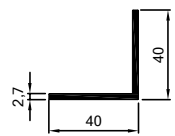
5052 0.515 kg/m 	5049 1.873 kg/m 	5050 1.635 kg/m 	5051 1.253 kg/m 
5080 1.106 kg/m 	2046 2.176 kg/m 	5022 2.370 kg/m 	1662 2.591 kg/m 
1533 0.566 kg/m 			

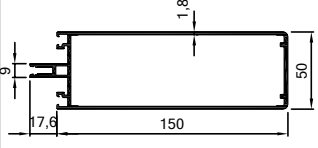
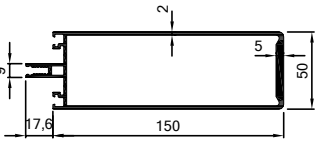
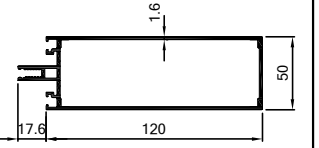
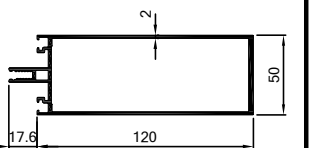
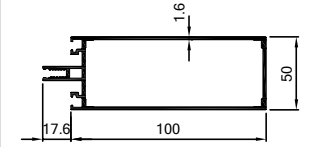
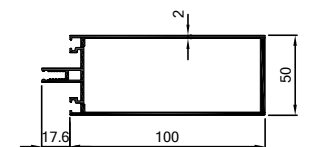
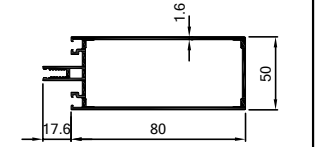
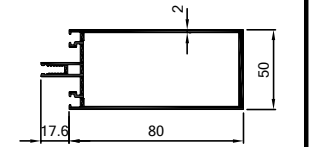
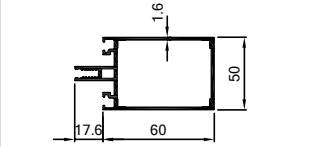
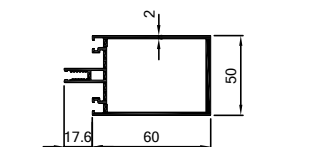
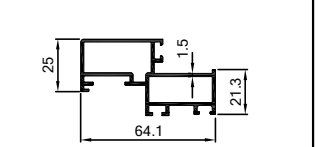
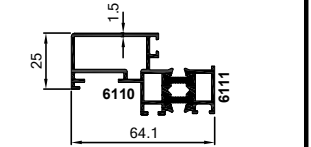
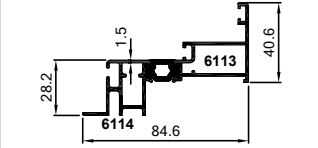
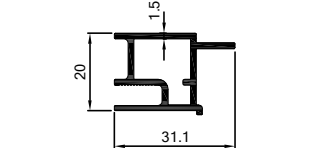
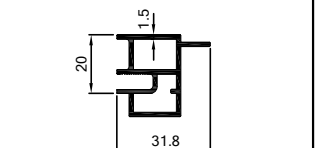
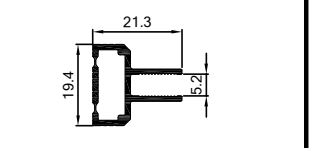
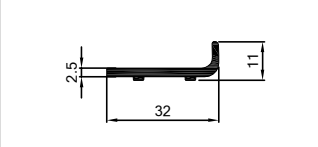
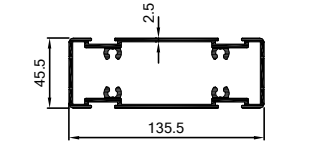
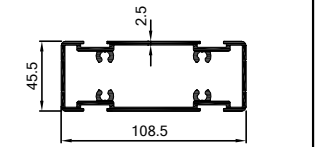
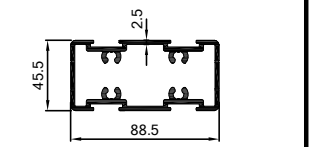
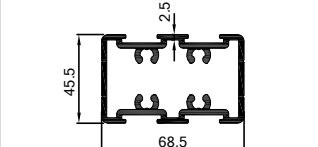
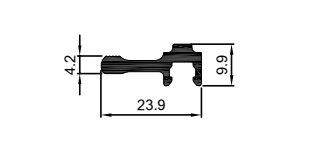
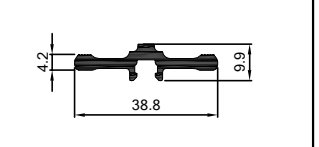
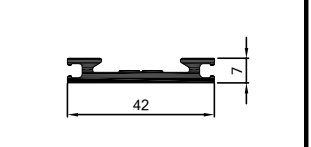
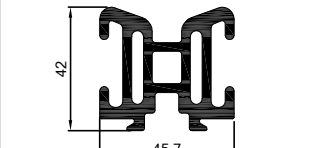
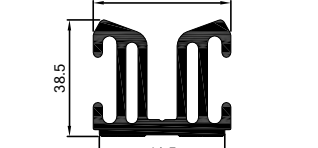
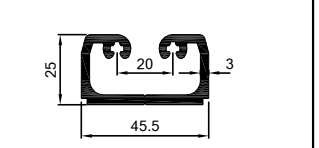
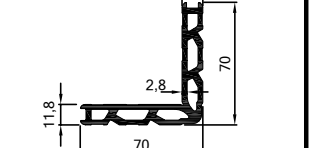
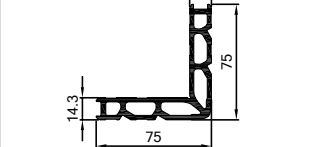
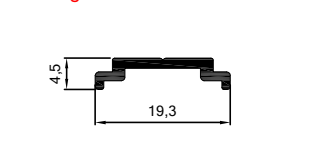

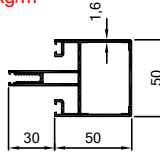
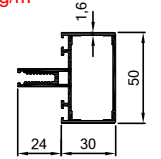
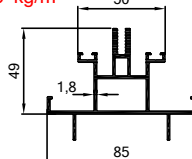
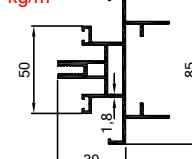
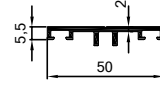
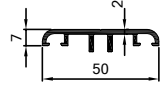
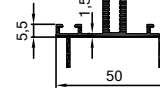
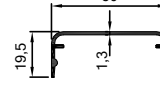
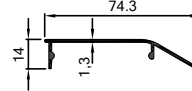
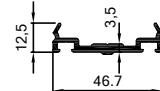
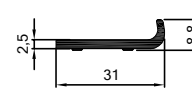
6100 2.421 kg/m 	6101 2.795 kg/m 	6102 1.854 kg/m 	6103 2.148 kg/m 
6104 1.681 kg/m 	6105 1.931 kg/m 	6106 1.507 kg/m 	6107 1.714 kg/m 
6108 1.334 kg/m 	6109 1.497 kg/m 	6112 0.985 kg/m 	6110-6111 1.224 kg/m 
6113-6114 1.317 kg/m 	6115 0.411 kg/m 	6116 0.530 kg/m 	6117 0.250 kg/m 
6120 0.265 kg/m 	6122 3.119 kg/m 	6123 2.753 kg/m 	6125 2.484 kg/m 
6124 2.199 kg/m 	6118 0.261 kg/m 	6119 0.390 kg/m 	5040 0.456 kg/m 
5041 2.211 kg/m 	6121 2.027 kg/m 	5042 1.144 kg/m 	5022 2.370 kg/m 
1662 2.591 kg/m 	8241 0.099 kg/m 		

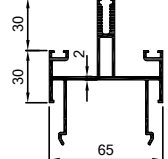
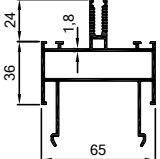
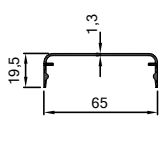
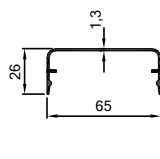
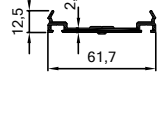
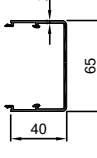
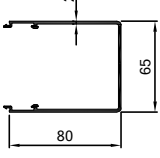
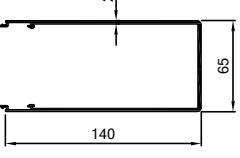
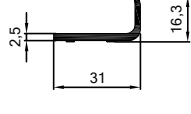
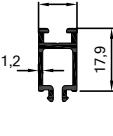
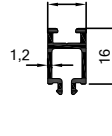
5008 1.596 kg/m 	5013 1.149 kg/m 	5108 1.585 kg/m 	5109 1.653 kg/m 
5110 0.390 kg/m 	5111 0.429 kg/m 	5112 0.617 kg/m 	5046 0.334 kg/m 
5047 0.369 kg/m 	5048 0.467 kg/m 	5058 0.244 kg/m 	

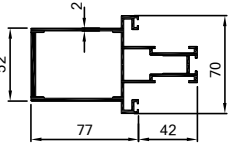
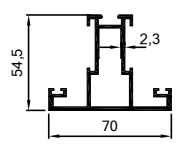
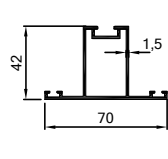
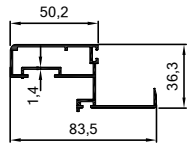
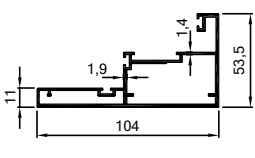
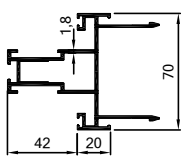
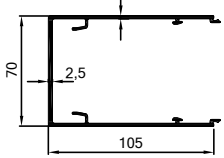

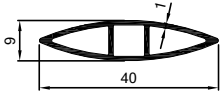
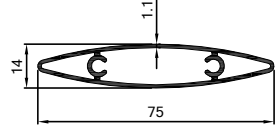
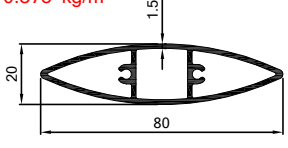
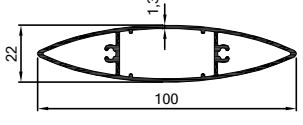
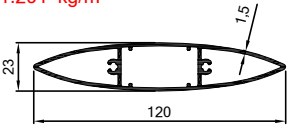
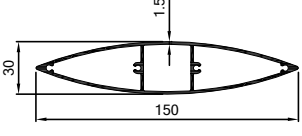
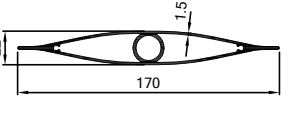
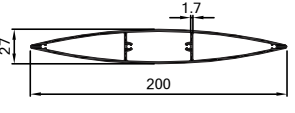
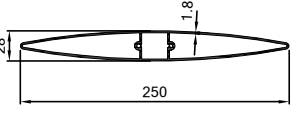
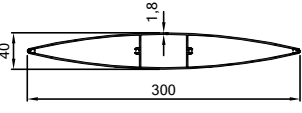
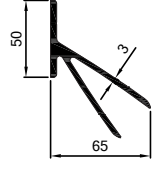
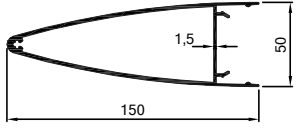
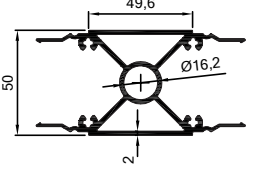
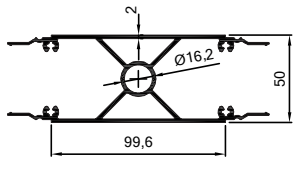
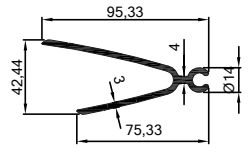
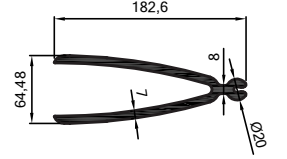
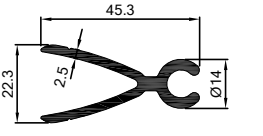
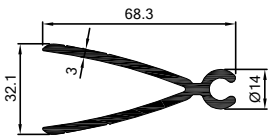
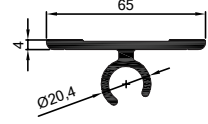
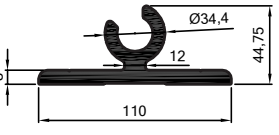
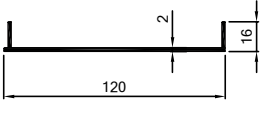
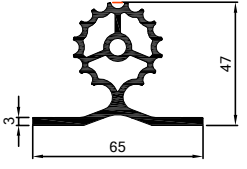
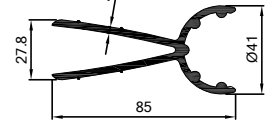
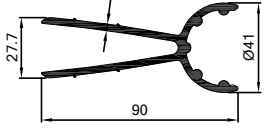
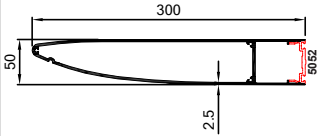
5100 1.610 kg/m 	5101 1.723 kg/m 	5102 0.385 kg/m 	5103 0.434 kg/m 
5104 0.569 kg/m 	5105 0.824 kg/m 	5106 1.258 kg/m 	5107 2.309 kg/m 
5113 0.282 kg/m 	5059 0.210 kg/m 	5097 0.198 kg/m 	

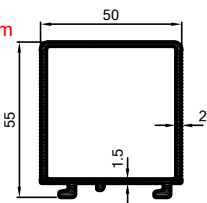
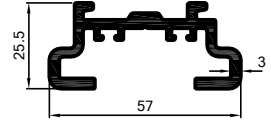
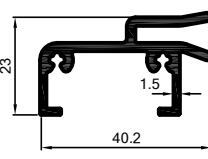
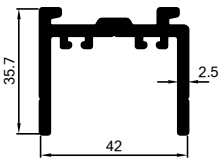
2031 2.618 kg/m 	2032 1.400 kg/m 	2033 0.886 kg/m 	2034 0.900 kg/m 
2035 1.615 kg/m 	2054 1.809 kg/m 	2055 1.823 kg/m 	

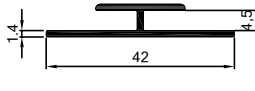
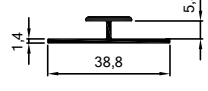
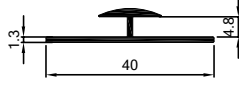
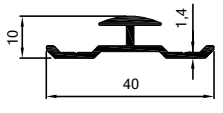
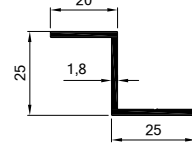
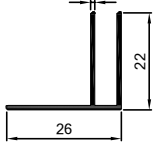
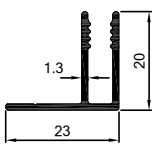
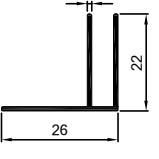
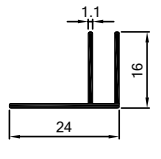
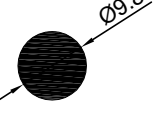
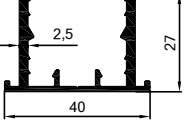
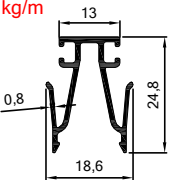
4830 0.252 kg/m 	6594 0.577 kg/m 	1982 0.873 kg/m 	6277 0.942 kg/m 
7699 1.291 kg/m 	1983 1.573 kg/m 	2036 1.713 kg/m 	1179 2.208 kg/m 
2785 2.805 kg/m 	6275 3.457 kg/m 	6276 1.732 kg/m 	4000 1.905 kg/m 
4001 2.062 kg/m 	4004 2.666 kg/m 	4002 1.438 kg/m 	4005 6.840 kg/m 
3955 0.677 kg/m 	3956 1.135 kg/m 	4003 1.050 kg/m 	4006 3.688 kg/m 
2037 0.802 kg/m 	4197 1.500 kg/m 	4198 1.662 kg/m 	4199 1.748 kg/m 
8369 4.435 kg/m 			

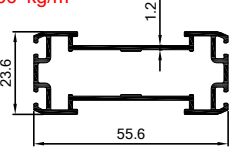
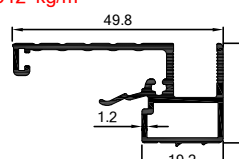
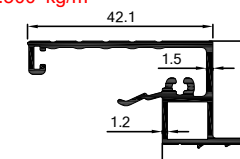
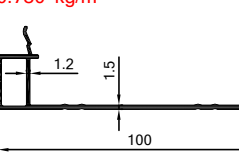
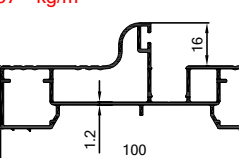
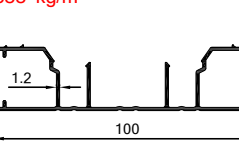
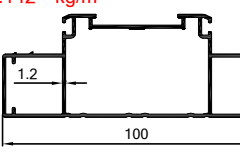
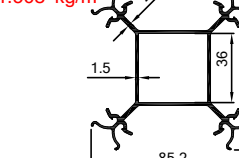
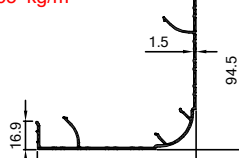
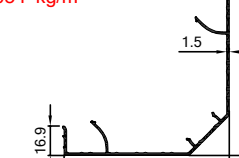
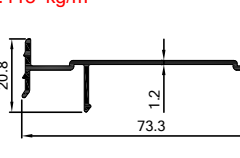
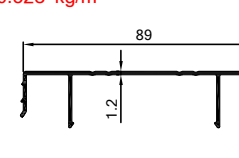
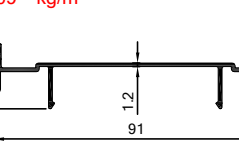
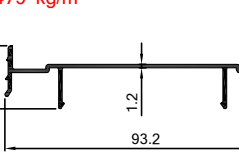
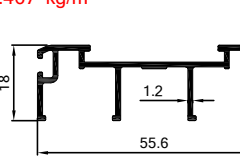
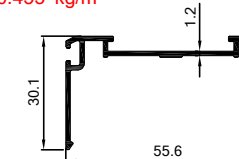
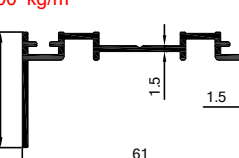
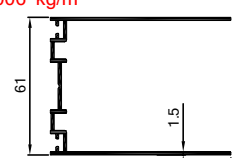
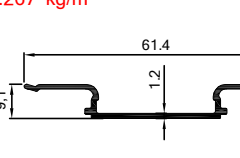
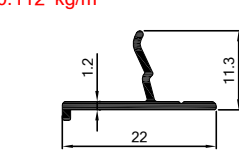
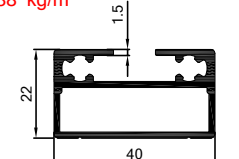
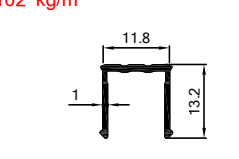
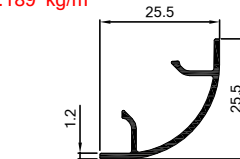
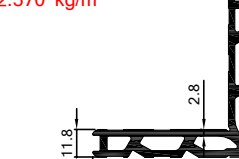
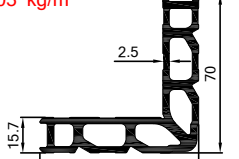
<p>6070 0.988 kg/m</p> 	<p>6071 1.006 kg/m</p> 	<p>6072 0.584 kg/m</p> 	<p>6073 0.884 kg/m</p> 
<p>278 0.219 kg/m</p> 	<p>507 0.251 kg/m</p> 	<p>3117 0.225 kg/m</p> 	<p>4037 0.237 kg/m</p> 
<p>7476 0.257 kg/m</p> 	<p>6549 0.323 kg/m</p> 	<p>513 0.184 kg/m</p> 	<p>477 0.220 kg/m</p> 
<p>5651 0.205 kg/m</p> 	<p>5652 0.160 kg/m</p> 	<p>4320 0.204 kg/m</p> 	<p>6937 0.576 kg/m</p> 
<p>6938 0.249 kg/m</p> 			

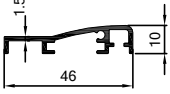
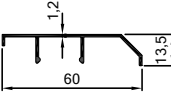
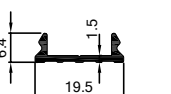
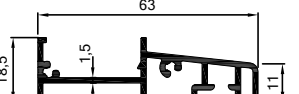
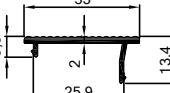
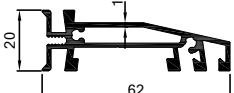
<p>7121 0.666 kg/m</p> 	<p>7122 0.542 kg/m</p> 	<p>7138 0.500 kg/m</p> 	<p>7127 0.780 kg/m</p> 
<p>7126 1.137 kg/m</p> 	<p>7132 0.888 kg/m</p> 	<p>7133 1.142 kg/m</p> 	<p>7137 1.568 kg/m</p> 
<p>7135 1.065 kg/m</p> 	<p>7136 1.034 kg/m</p> 	<p>7139 0.413 kg/m</p> 	<p>7134 0.528 kg/m</p> 
<p>7140 0.509 kg/m</p> 	<p>7141 0.479 kg/m</p> 	<p>7129 0.467 kg/m</p> 	<p>7130 0.455 kg/m</p> 
<p>7131 0.600 kg/m</p> 	<p>7128 1.006 kg/m</p> 	<p>7123 0.267 kg/m</p> 	<p>7125 0.112 kg/m</p> 
<p>1931 0.688 kg/m</p> 	<p>7124 0.102 kg/m</p> 	<p>7142 0.189 kg/m</p> 	<p>5022 2.370 kg/m</p> 
<p>1695 2.603 kg/m</p> 			

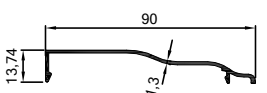
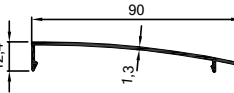
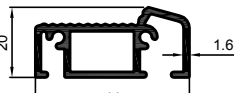
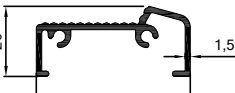
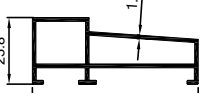
991 0.330 kg/m 	268 0.309 kg/m 	269 0.114 kg/m 	2681 0.637 kg/m 
2682 0.220 kg/m 	838 0.830 kg/m 	2619 0.443 kg/m 	2620 0.408 kg/m 
2621 0.399 kg/m 	2996 0.640 kg/m 	7521 0.446 kg/m 	1206 0.656 kg/m 

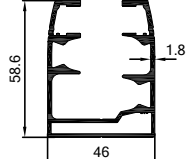
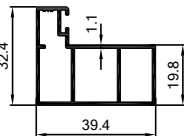
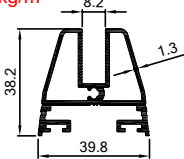
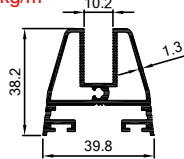
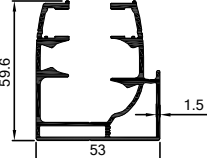
<p>6436 1.436 kg/m</p> 	<p>6439 0.544 kg/m</p> 	<p>6437 0.866 kg/m</p> 	<p>6438 0.866 kg/m</p> 
<p>6499 1.526 kg/m</p> 			

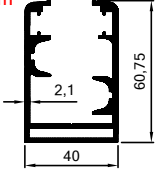
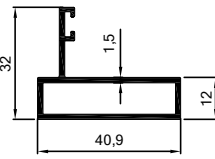
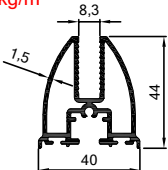
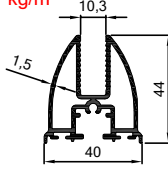
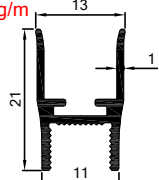
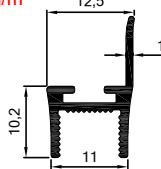
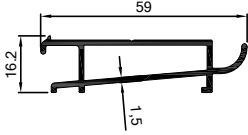
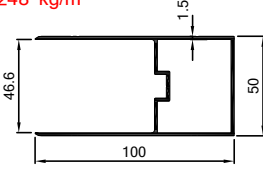
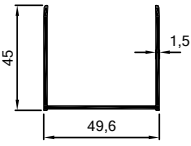
<p>3962 1.475 kg/m</p> 	<p>3945 0.515 kg/m</p> 	<p>3961 0.993 kg/m</p> 	<p>3990 0.991 kg/m</p> 
<p>7326 0.169 kg/m</p> 	<p>7327 0.142 kg/m</p> 	<p>7617 0.538 kg/m</p> 	<p>7618 1.248 kg/m</p> 
<p>8249 0.554 kg/m</p> 			

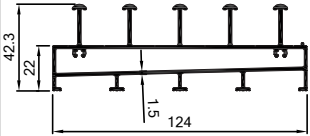
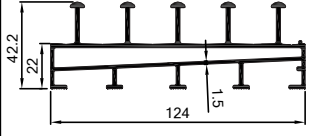
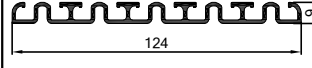
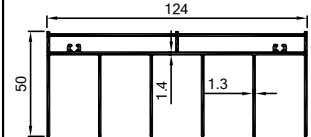
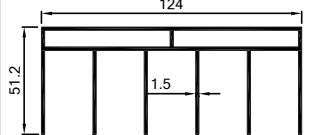
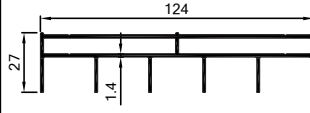
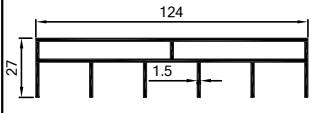
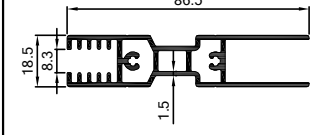
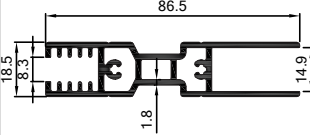
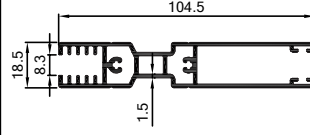
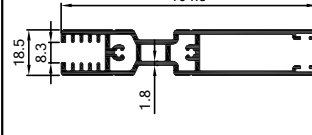
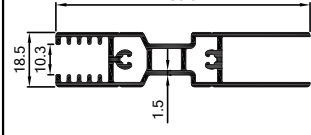
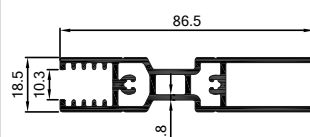
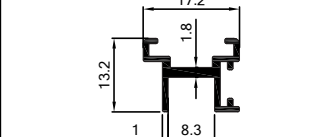
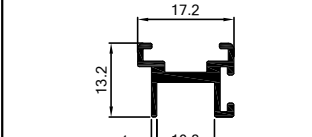
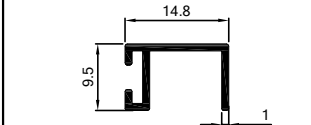
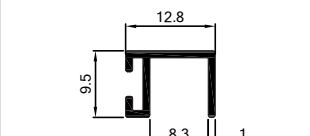
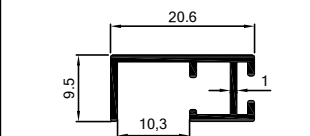
<p>7201 2.076 kg/m</p> 	<p>7192 2.295 kg/m</p> 	<p>7181 1.127 kg/m</p> 	<p>7197 1.954 kg/m</p> 
<p>7182 2.143 kg/m</p> 	<p>7198 1.381 kg/m</p> 	<p>7183 1.495 kg/m</p> 	<p>7199 1.157 kg/m</p> 
<p>7184 1.323 kg/m</p> 	<p>7202 1.354 kg/m</p> 	<p>7203 1.534 kg/m</p> 	<p>7200 1.122 kg/m</p> 
<p>7188 1.287 kg/m</p> 	<p>7185 0.159 kg/m</p> 	<p>7189 0.173 kg/m</p> 	<p>7191 0.103 kg/m</p> 
<p>7187 0.098 kg/m</p> 	<p>7190 0.143 kg/m</p> 	<p>7186 0.143 kg/m</p> 