

E115

ISI YALITIMLI KALDIR - SÜR SİSTEMLERİ

INSULATED LIFT & SLIDE SYSTEMS



E 115



COD Code	PROFİL KESİTİ Profile View	PROFİL AÇIKLAMASI Profile Description	AGIRLIK (kg/m) Weight	Jxx cm ⁴	Jyy cm ⁴
4600		KASA PROFİLİ	2,271	19,03	100,24
4601		KASA PROFİLİ	3,547	28,51	359,09
4602		KASA PROFİLİ	2,228	16,06	95,60
4603		KASA PROFİLİ	2,452	25,69	112,90
4604		KANAT PROFİLİ	1,828	18,35	4,21
4605		ORTA KAYIT PROFİLİ	1,877	21,89	54,04
4606		ORTA KAYIT PROFİLİ	2,314	21,55	84,19
4607		ÇİFT KANAT ADAPTÖR PROF.	0,971	---	---
4608		KENET PROFİLİ	0,585	---	---
4609		ÇİTA PROFİLİ	0,628	---	---
4610		KANAT TAŞIYICI PROFİLİ	0,809	---	---



COD Code	PROFİL KESİTİ Profile View	PROFİL AÇIKLAMASI Profile Description	AGIRLIK (kg/m) Weight	Jxx cm ⁴	Jyy cm ⁴
5118		CAM ÇITASI PROFİLİ	0,249	----	----
5119		CAM ÇITASI PROFİLİ	0,251	----	----
5120		CAM ÇITASI PROFİLİ	0,254	----	----
5121		CAM ÇITASI PROFİLİ	0,259	----	----
5122		CAM ÇITASI PROFİLİ	0,267	----	----
4550		KÖŞE TAKOZ PROFİLİ	3,581	----	----
5569		ORTA KAYIT BAĞ. PROFİLİ	0,555	----	----



E 115

PROFİLLER *PROFILES*

ISI YALITIMLI KALDIR - SÜR SİSTEMLER
INSOLATED LIFT&SLIDE SYSTEM



COD Code	AGIRLIK (kg/m) Weight	Jxx cm ⁴	Jyy cm ⁴	Wxx cm ³	Wyy cm ³	L m
4600	2,271	19,03	100,24	-----	-----	6
4601	3,547	28,51	359,09	-----	-----	6

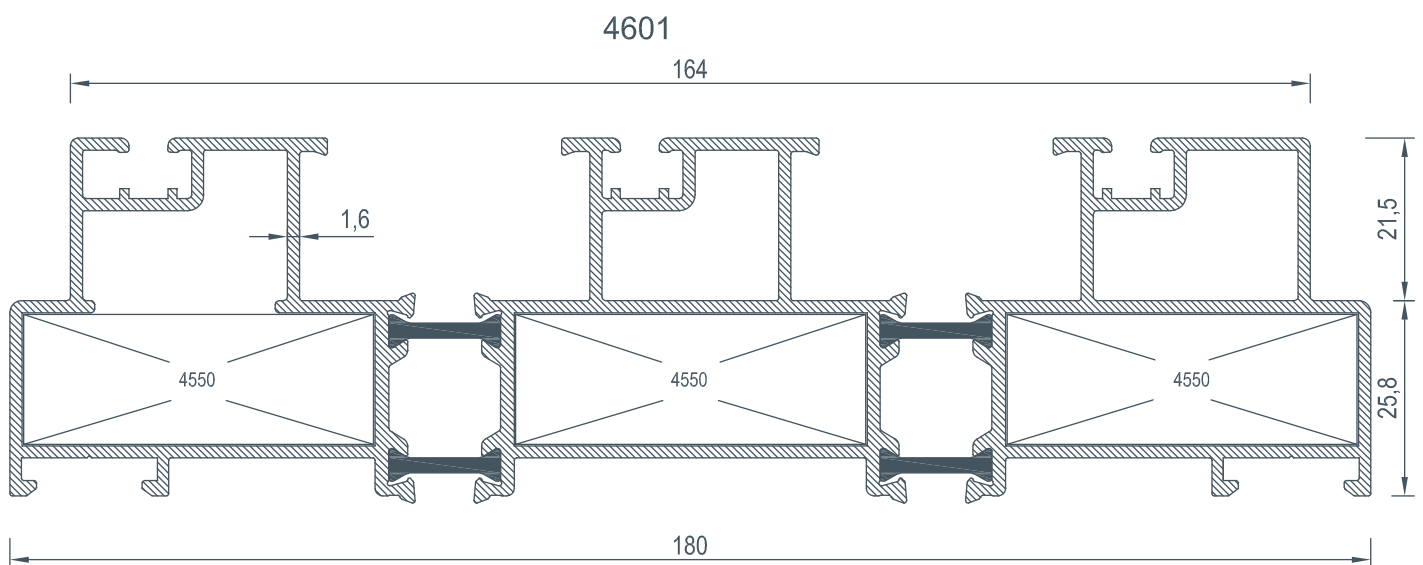
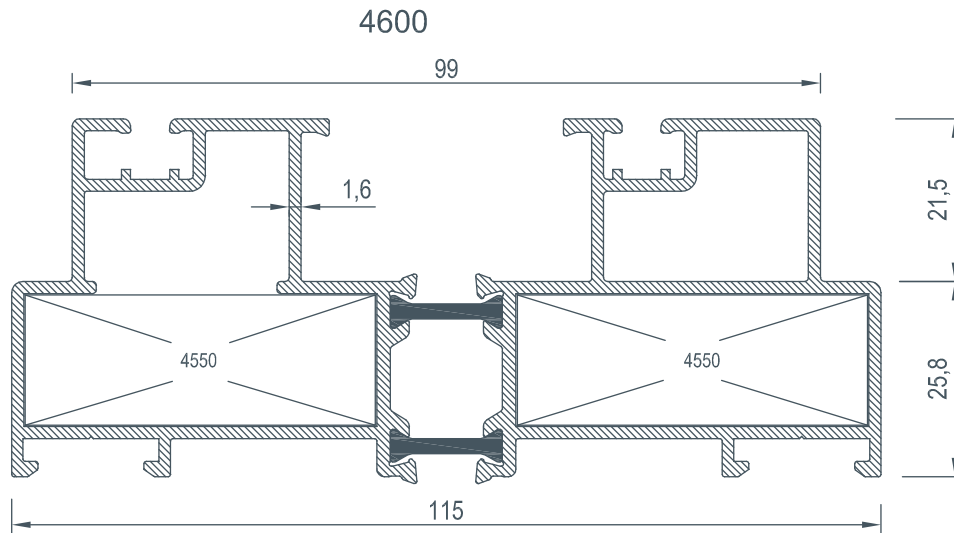



COD Code	AGIRLIK (kg/m) Weight	Jxx cm4	Jyy cm4	Wxx cm3	Wyy cm3	L m
4602	2,228	16,06	95,60	-----	-----	6
4603	2,452	25,69	112,90	-----	-----	6

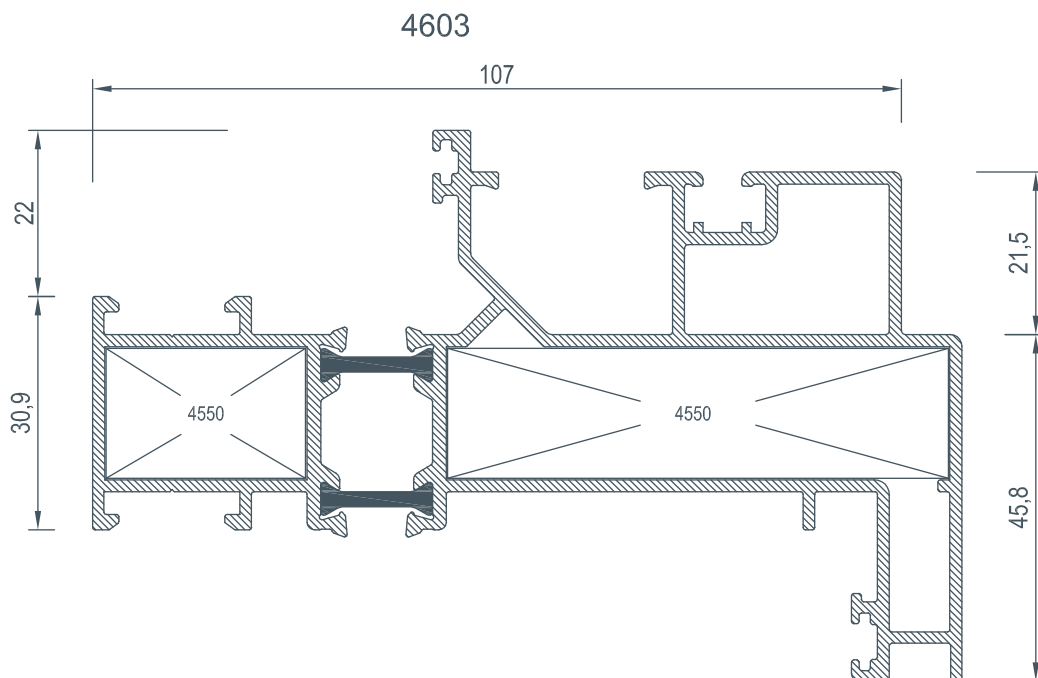
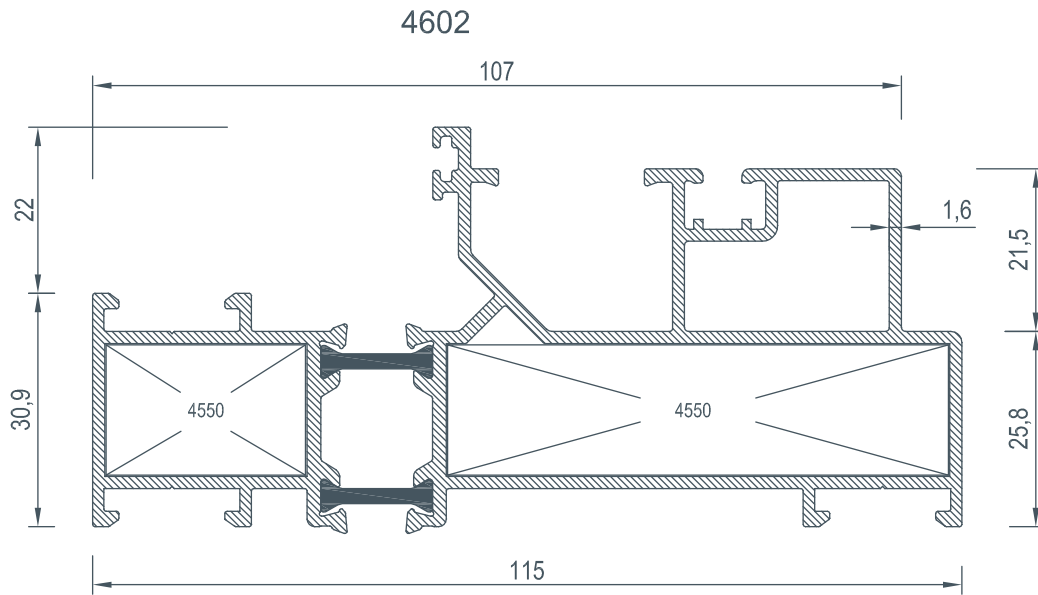



COD Code	AGIRLIK (kg/m) Weight	Jxx cm ⁴	Jyy cm ⁴	Wxx cm ³	Wyy cm ³	L m
4604	1,828	18,35	4,21	----	-----	6
4605	1,877	21,89	54,04	----	-----	6

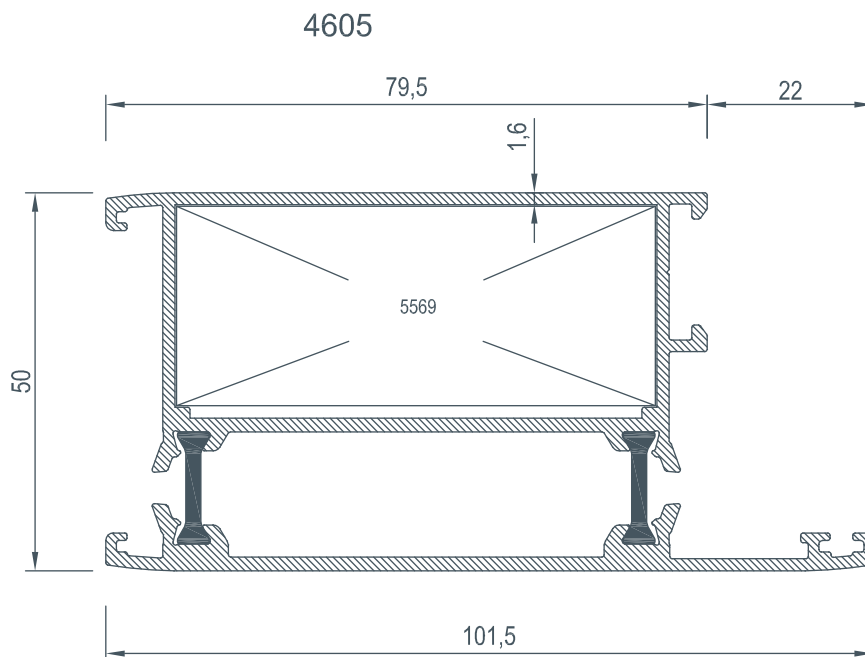
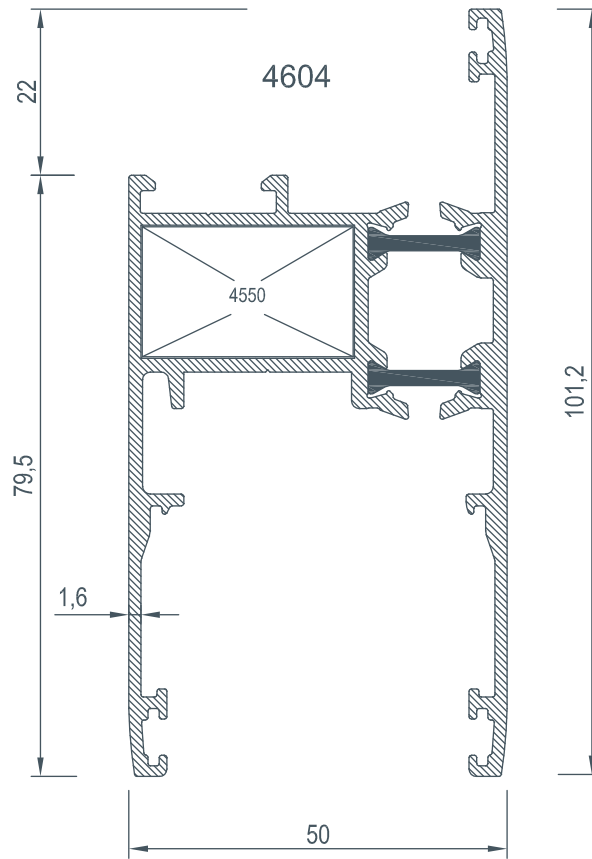



COD Code	AGIRLIK (kg/m) Weight	Jxx cm4	Jyy cm4	Wxx cm3	Wyy cm3	L m
4606	2,314	21,55	84,19	-----	-----	6
4607	0,971	-----	-----	-----	-----	6
4608	0,585	-----	-----	-----	-----	6

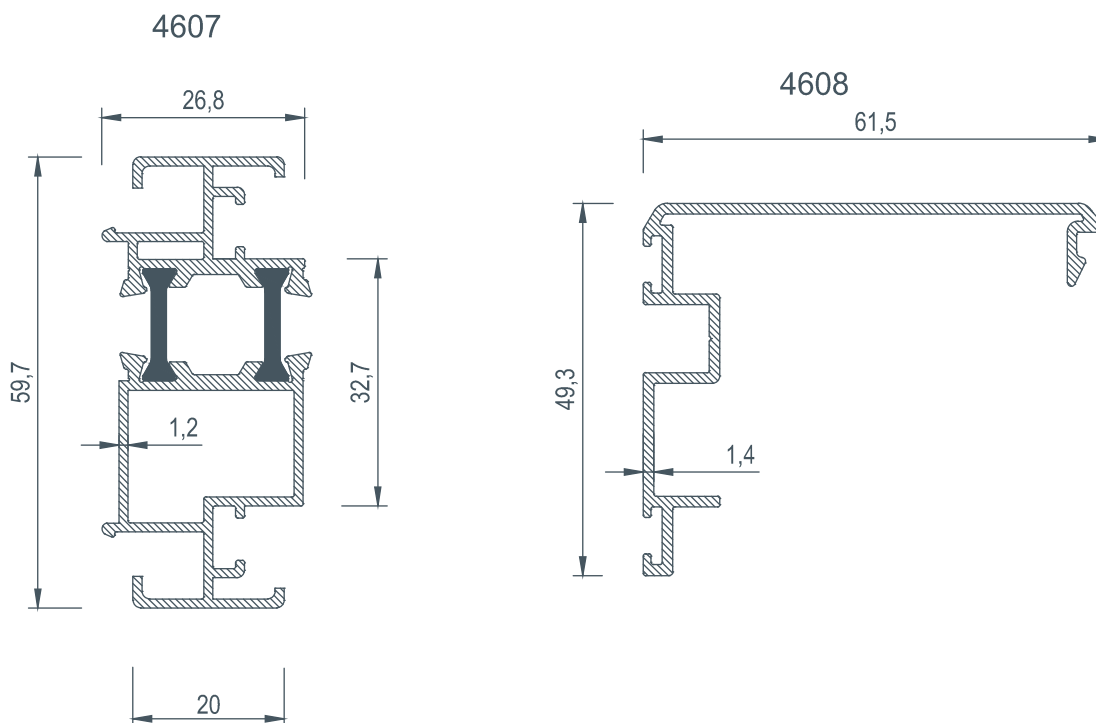
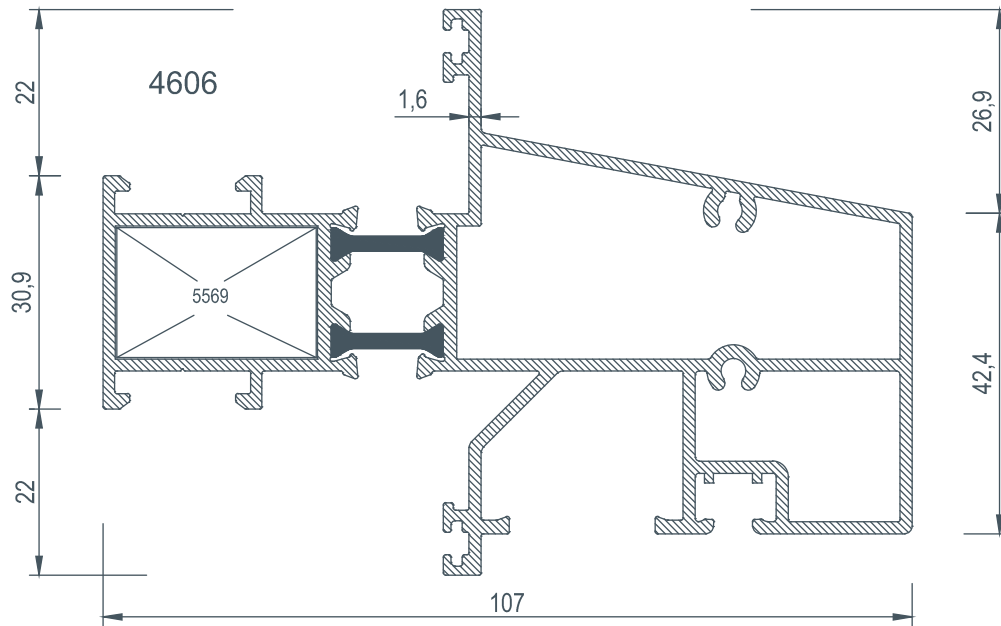



COD Code	AGIRLIK (kg/m) Weight	Jxx cm ⁴	Jyy cm ⁴	Wxx cm ³	Wyy cm ³	L m
4609	0,628	-----	-----	-----	-----	6
4610	0,809	-----	-----	-----	-----	6

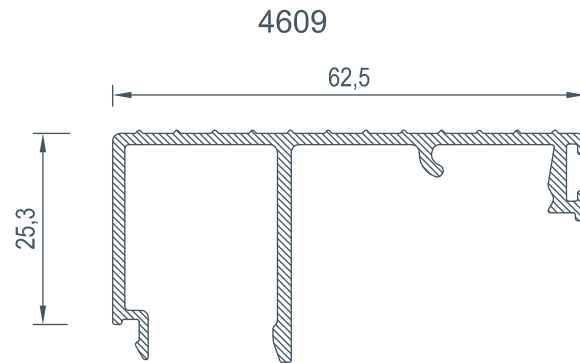
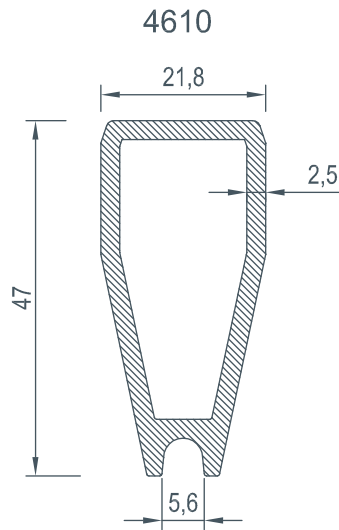



COD Code	AGIRLIK (kg/m) Weight	Jxx cm ⁴	Jyy cm ⁴	Wxx cm ³	Wyy cm ³	L m
4550	3,581	-----	-----	-----	-----	6

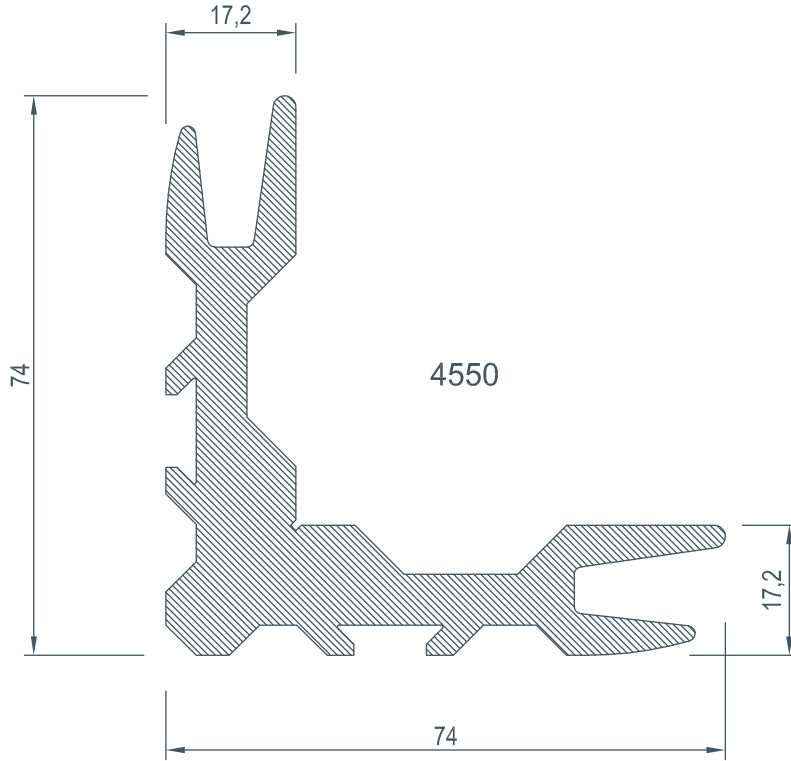



KÖŞE TAKOZLARI / Corner Cleats

Nr	 L m	AKS. KODU Acs. Code	KESİM ÖLÇÜSÜ Cutting Size
4600	4550	4550-46,3	46,3 mm
	4550	4550-46,3	46,3 mm
4601	4550	4550-46,3	46,3 mm
	4550	4550-46,3	46,3 mm
4602	4550	4550-26,3	26,3 mm
	4550	4550-66,2	66,2 mm
4603	4550	4550-26,3	26,3 mm
	4550	4550-66,2	66,2 mm
4604	4550	4550-27,8	27,8 mm

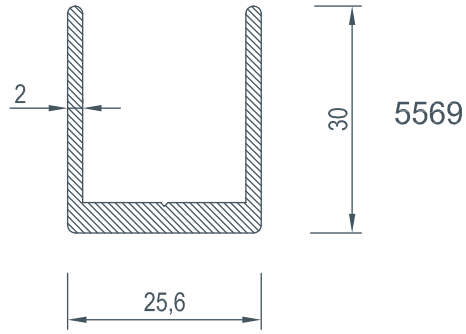

COD Code	AGIRLIK (kg/m) Weight	Jxx cm4	Jyy cm4	Wxx cm3	Wyy cm3	L m
5569	0,555	-----	-----	-----	-----	6

**ORTA KAYIT BAĞLANTI / Mullion Connection Piece**

Nr	 L m	 AKS. KODU Acs. Code	KESİM ÖLÇÜSÜ Cutting Size
4605	5569	5569-63,3	63,3 mm
4606	5569	5569-26,3	26,3 mm



COD Code	AGIRLIK (kg/m) Weight	Jxx cm4	Jyy cm4	Wxx cm3	Wyy cm3	L m
5118	0,249	-----	-----	-----	-----	6
5119	0,251	-----	-----	-----	-----	6
5120	0,254	-----	-----	-----	-----	6
5121	0,259	-----	-----	-----	-----	6
5122	0,267	-----	-----	-----	-----	6

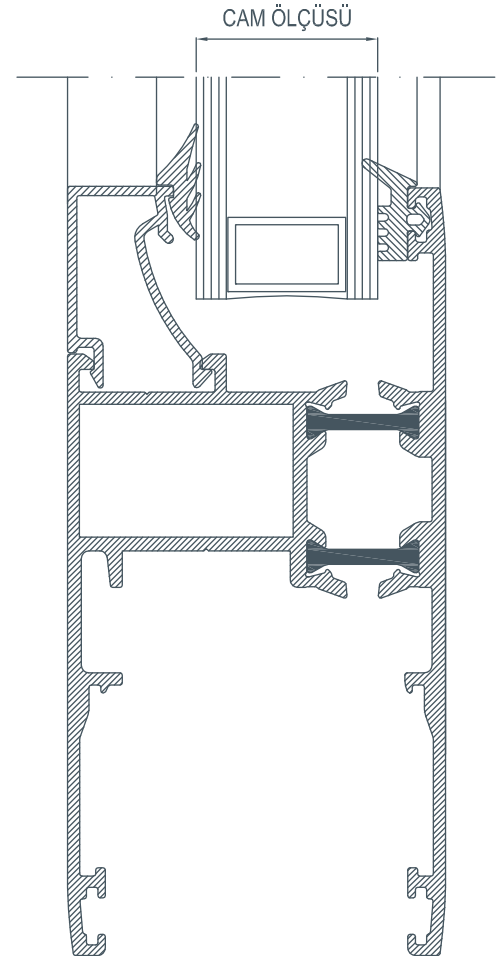
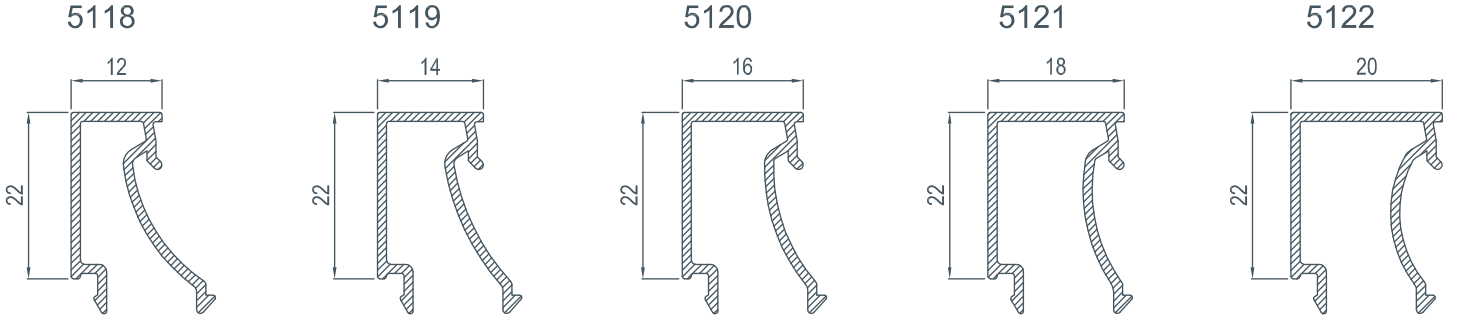

CAM ÇİTASI Glazing Bead	İÇ CAM FİTİLİ Glazing Gasket (in)	CAM KALINLIĞI Glas Thickness	DIŞ CAM FİTİLİ Glazing Gasket (out)
5118	E-01-001	26 mm	E-01-018
5119	E-01-001	24 mm	E-01-018
5120	E-01-001	22 mm	E-01-018
5122	E-01-001	20 mm	E-01-018
5123	E-01-001	18 mm	E-01-018



E 115

DETAYLAR
DETAILS

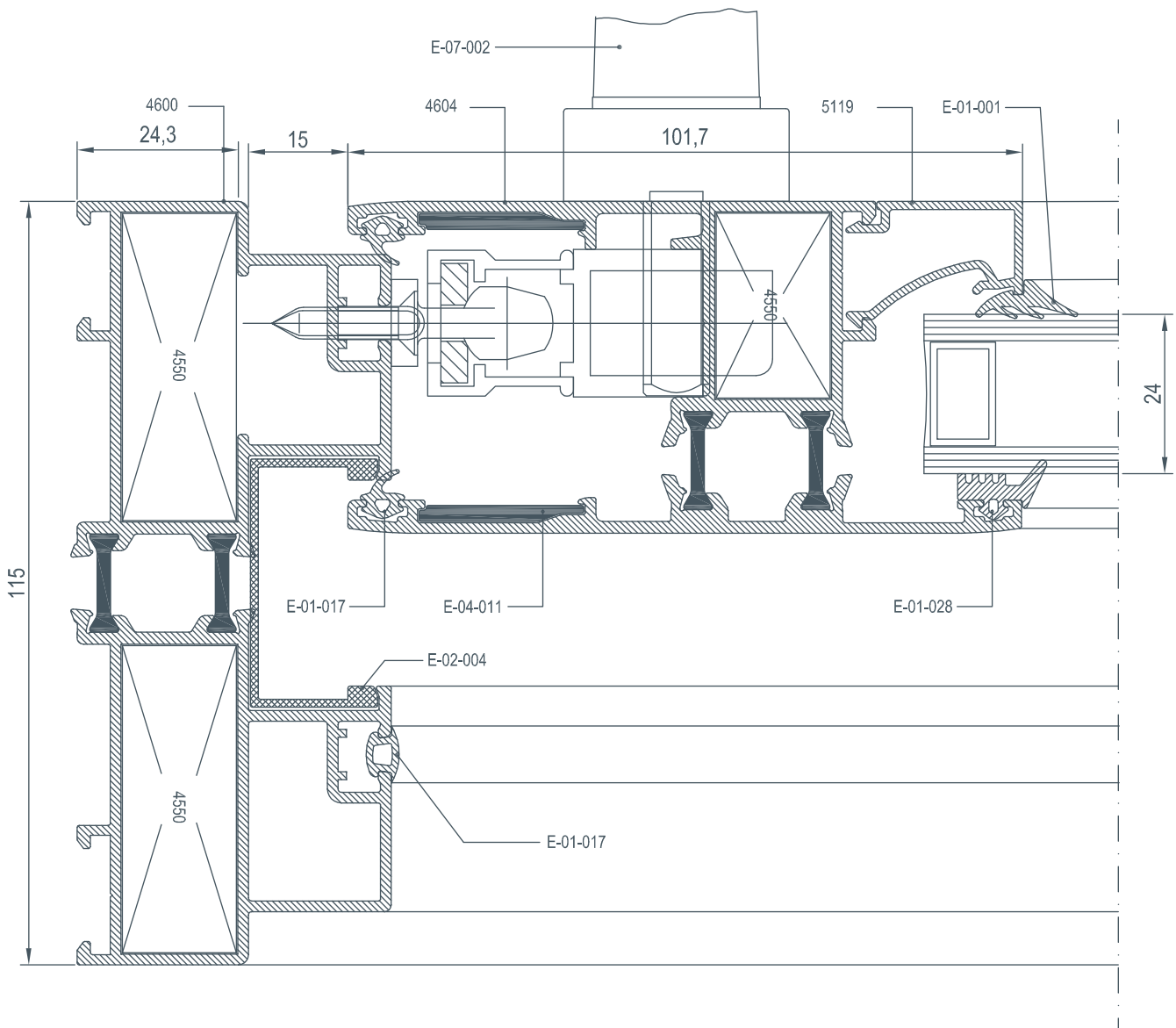
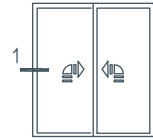

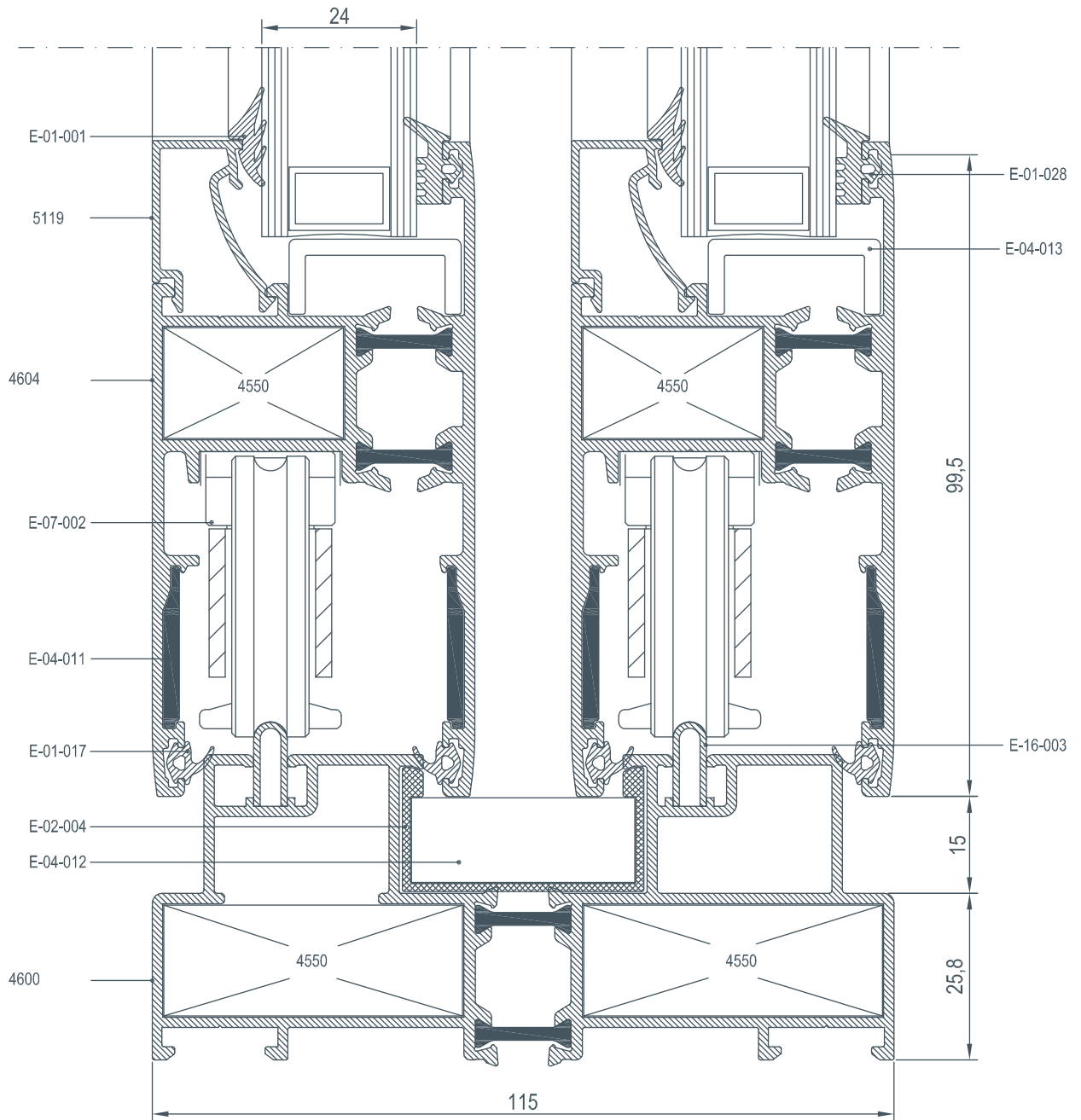

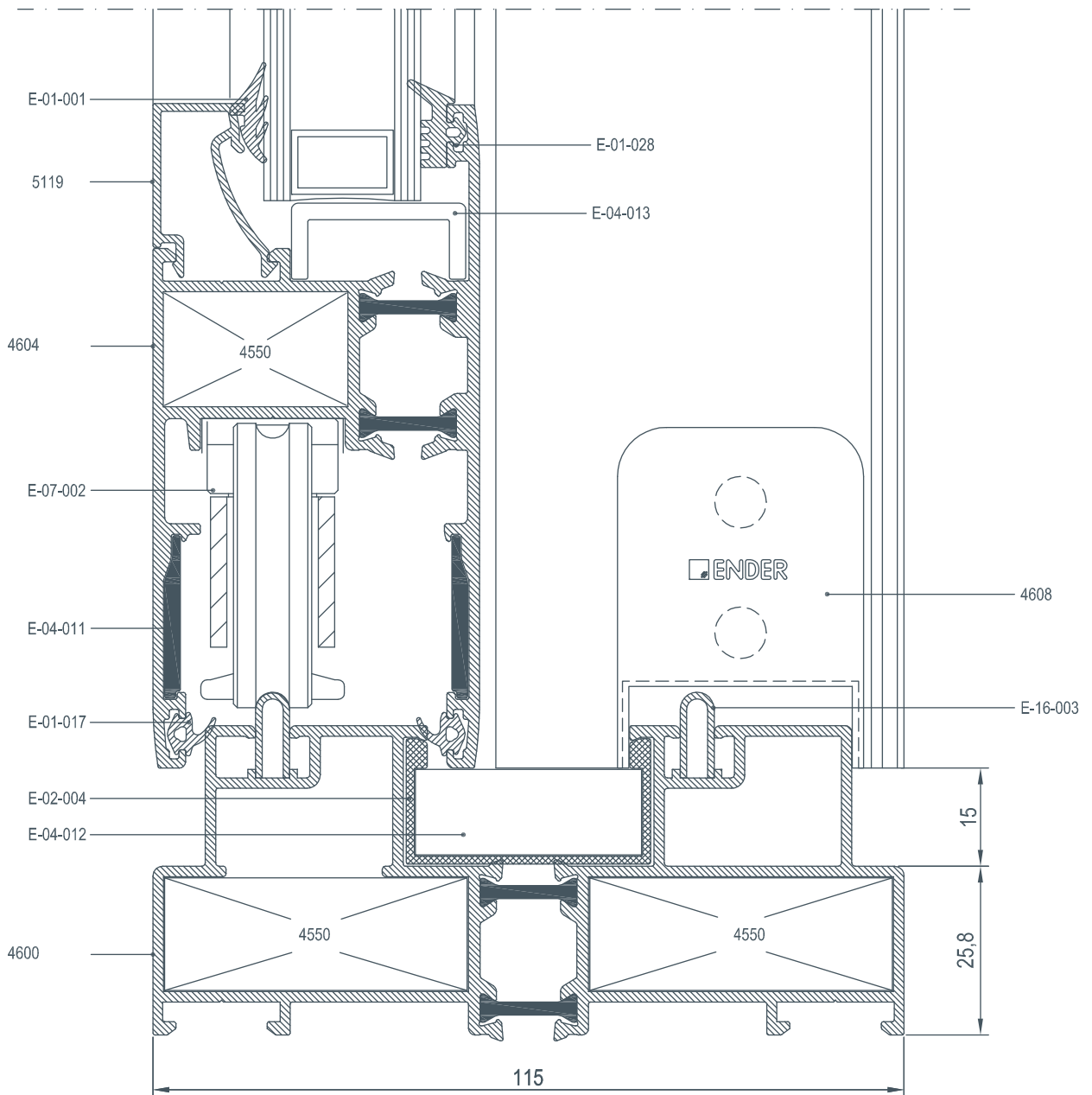
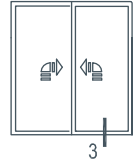

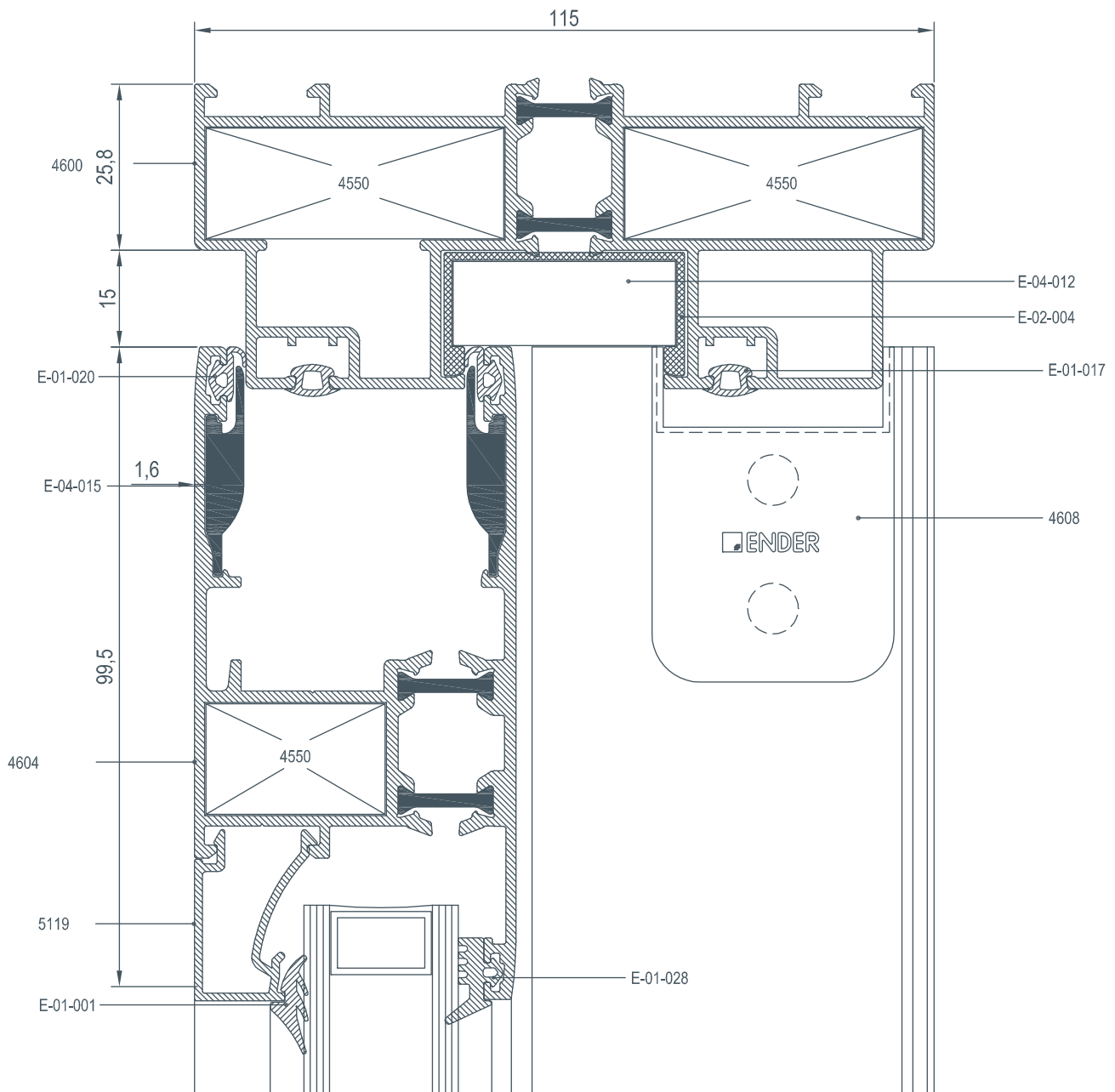
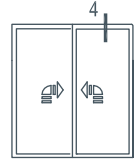

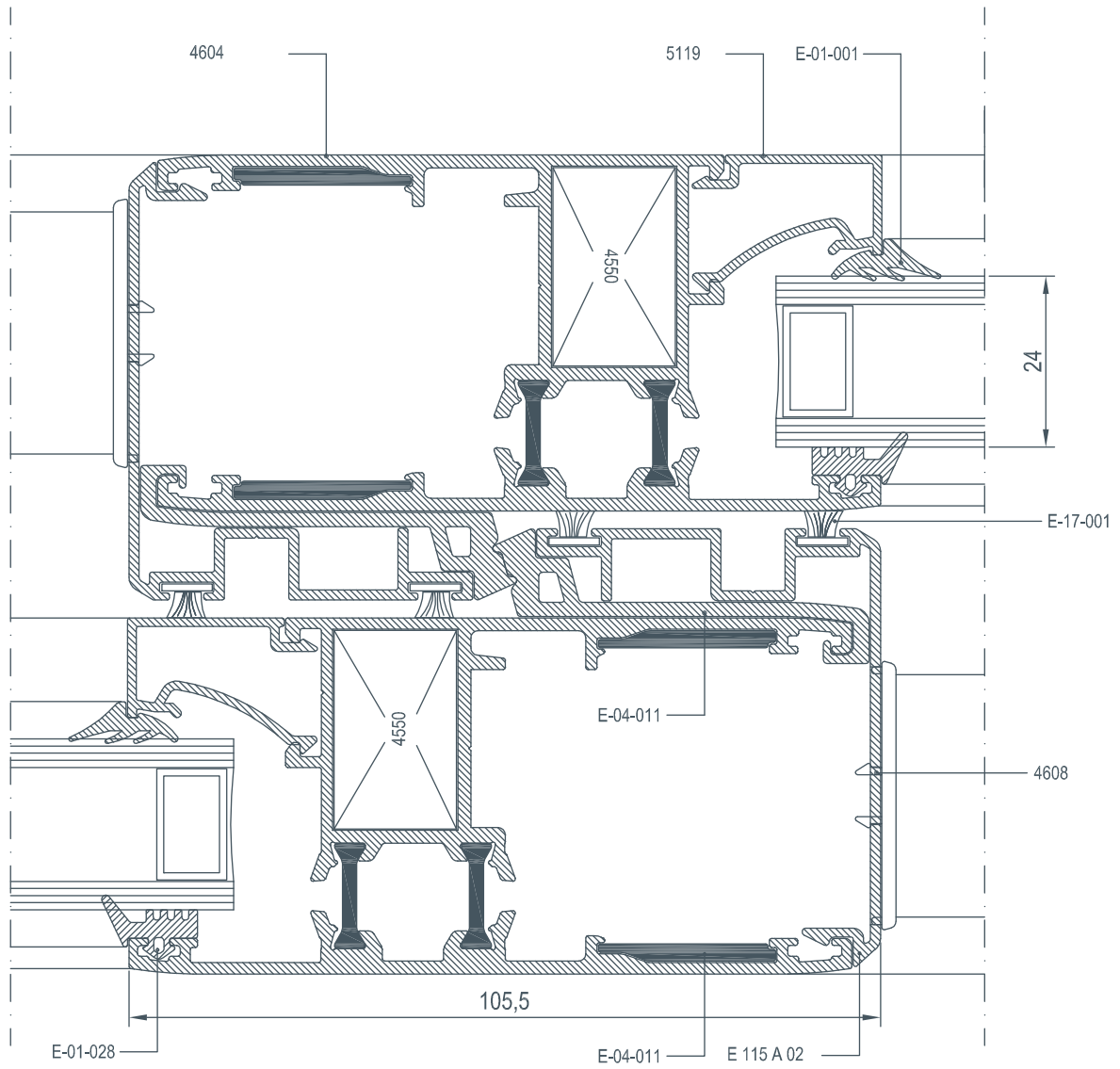
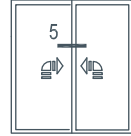

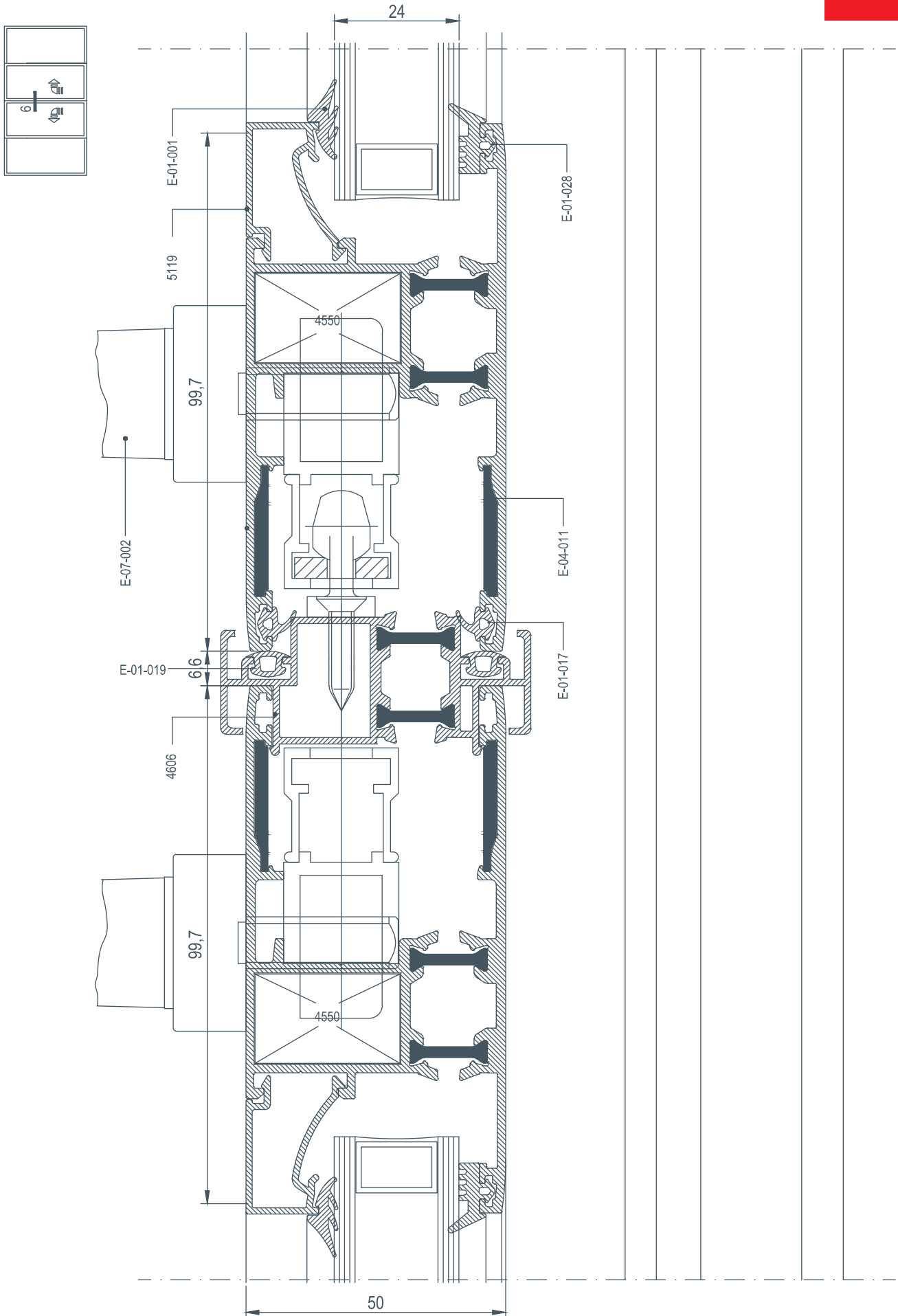

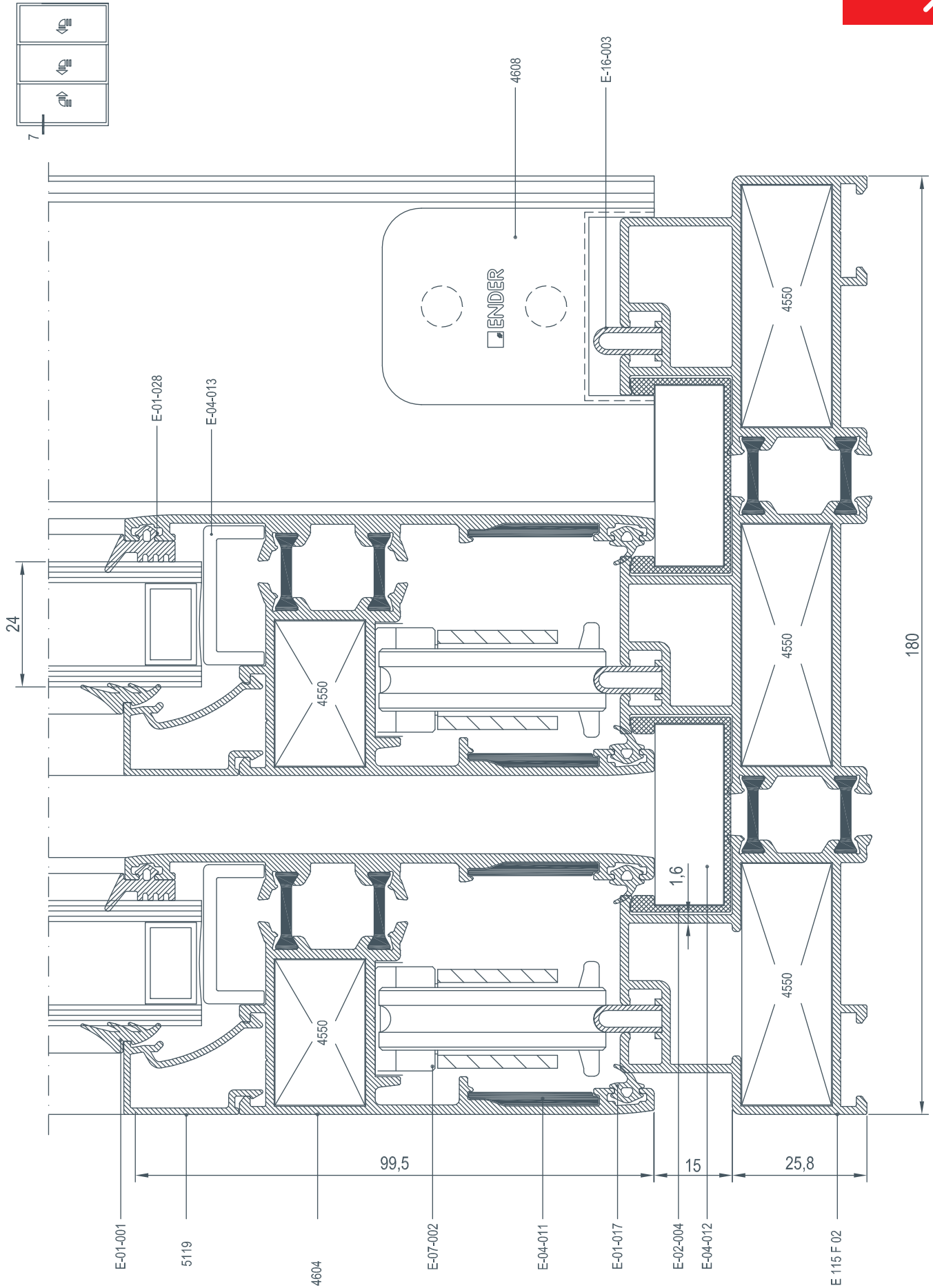

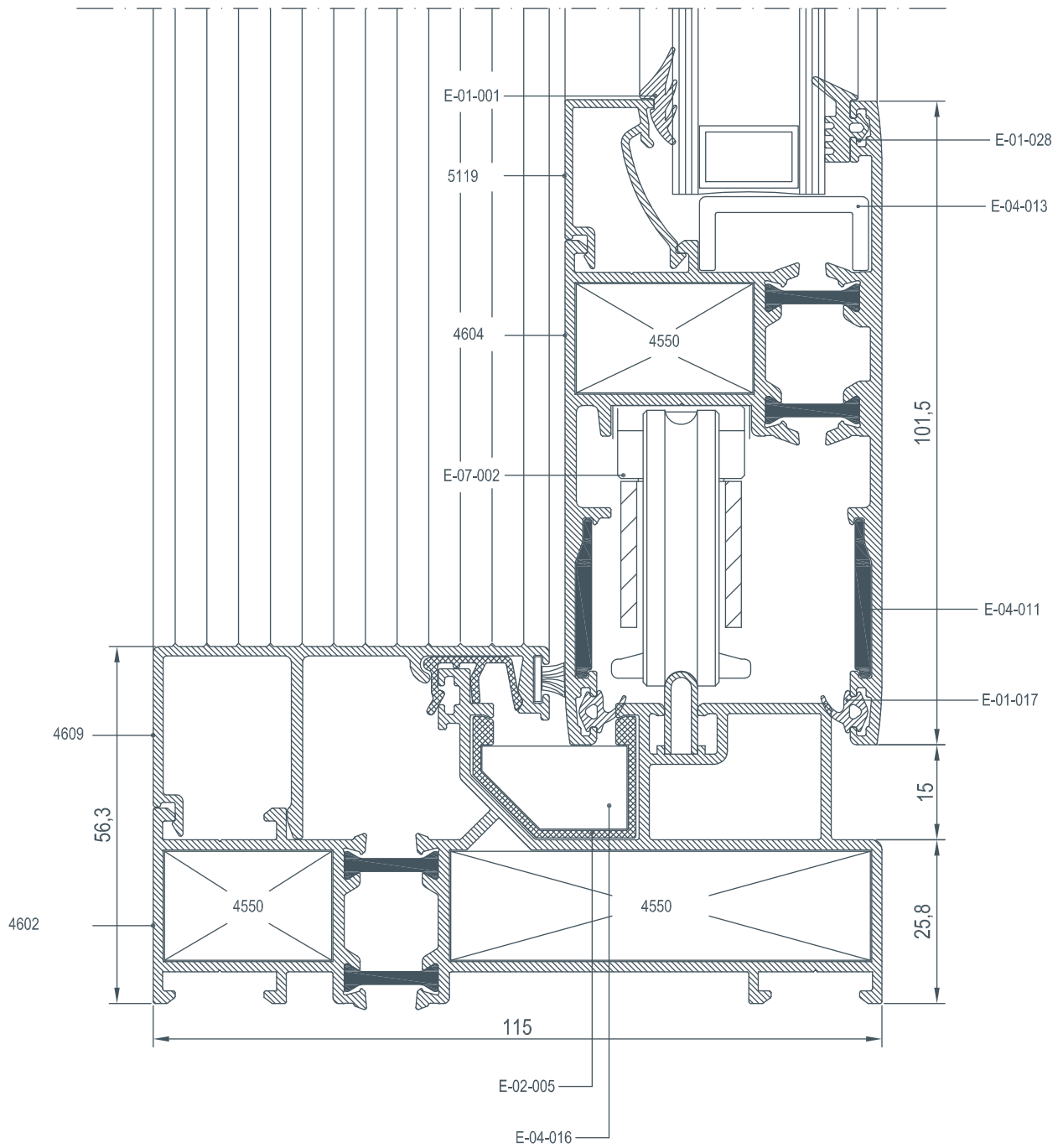

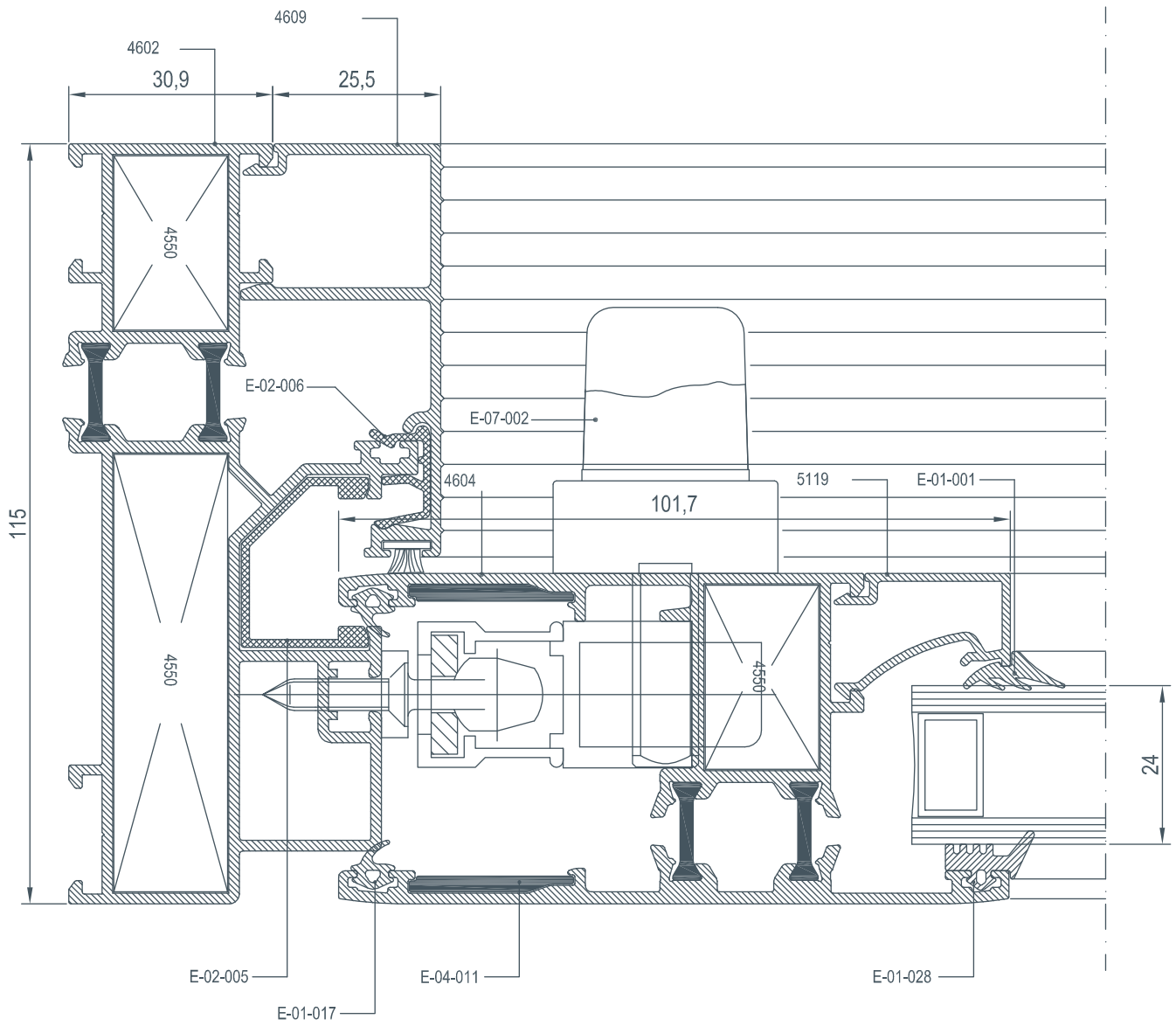
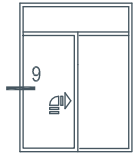

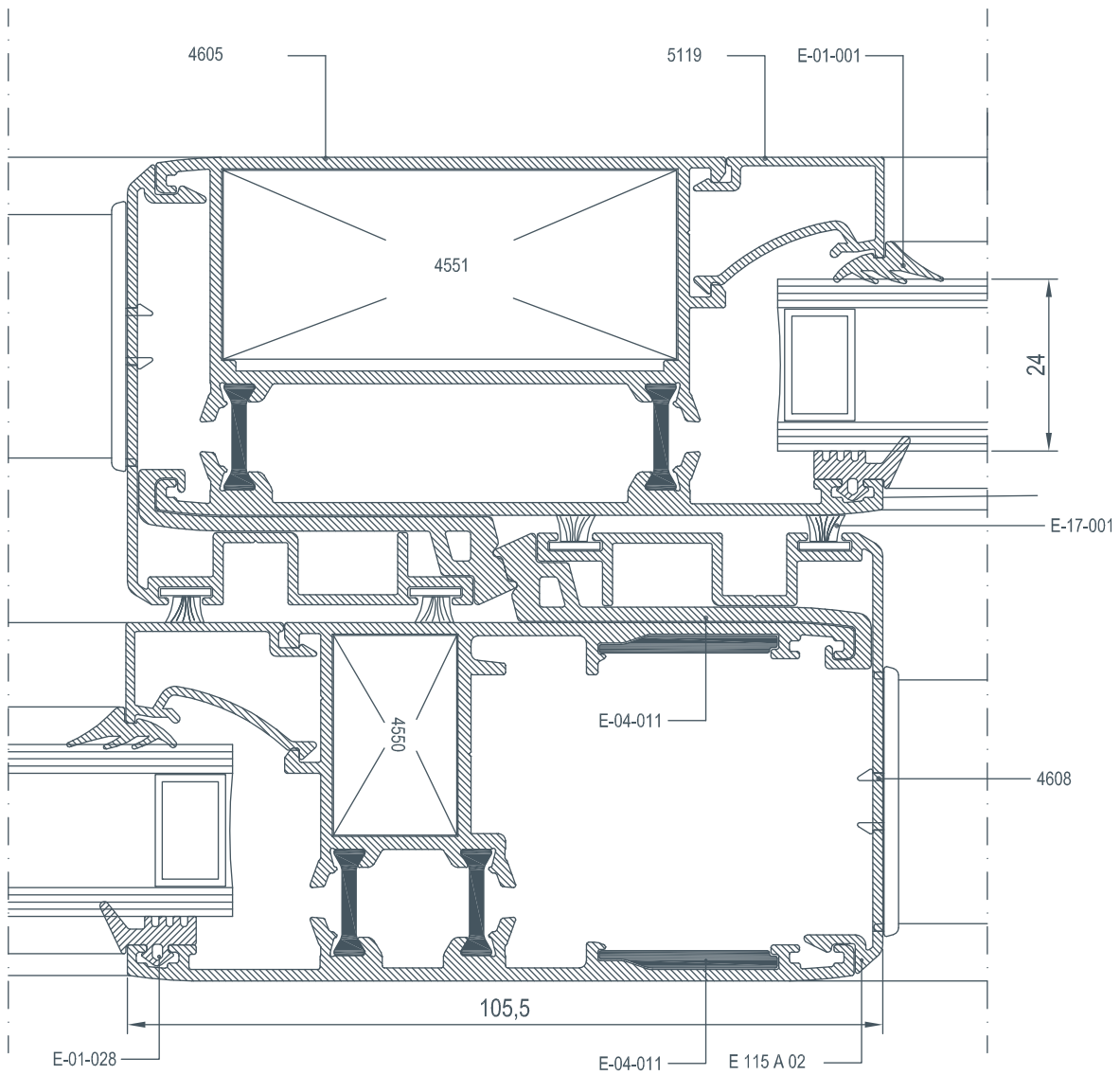
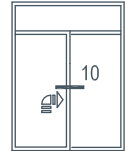

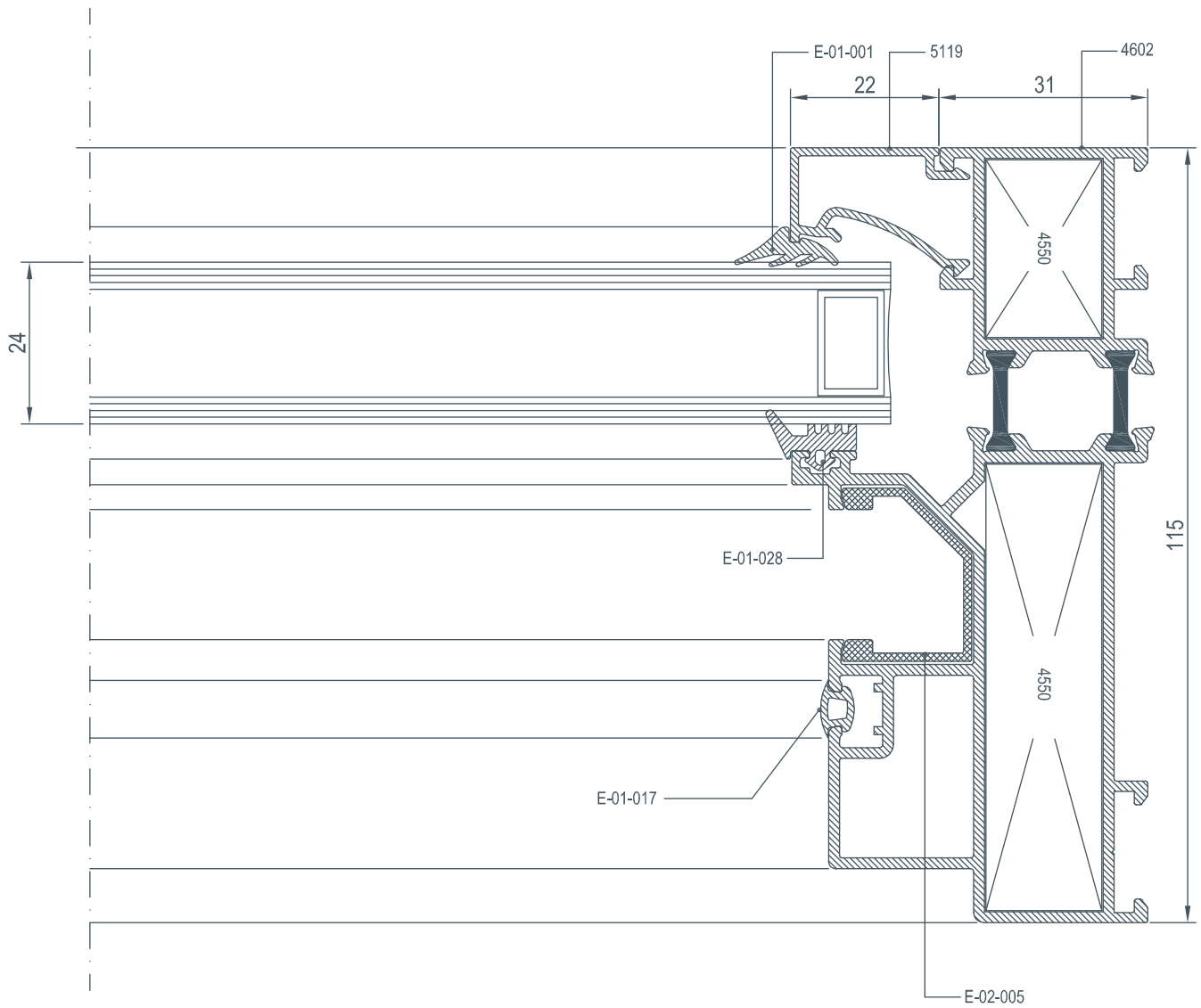
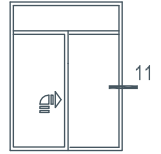

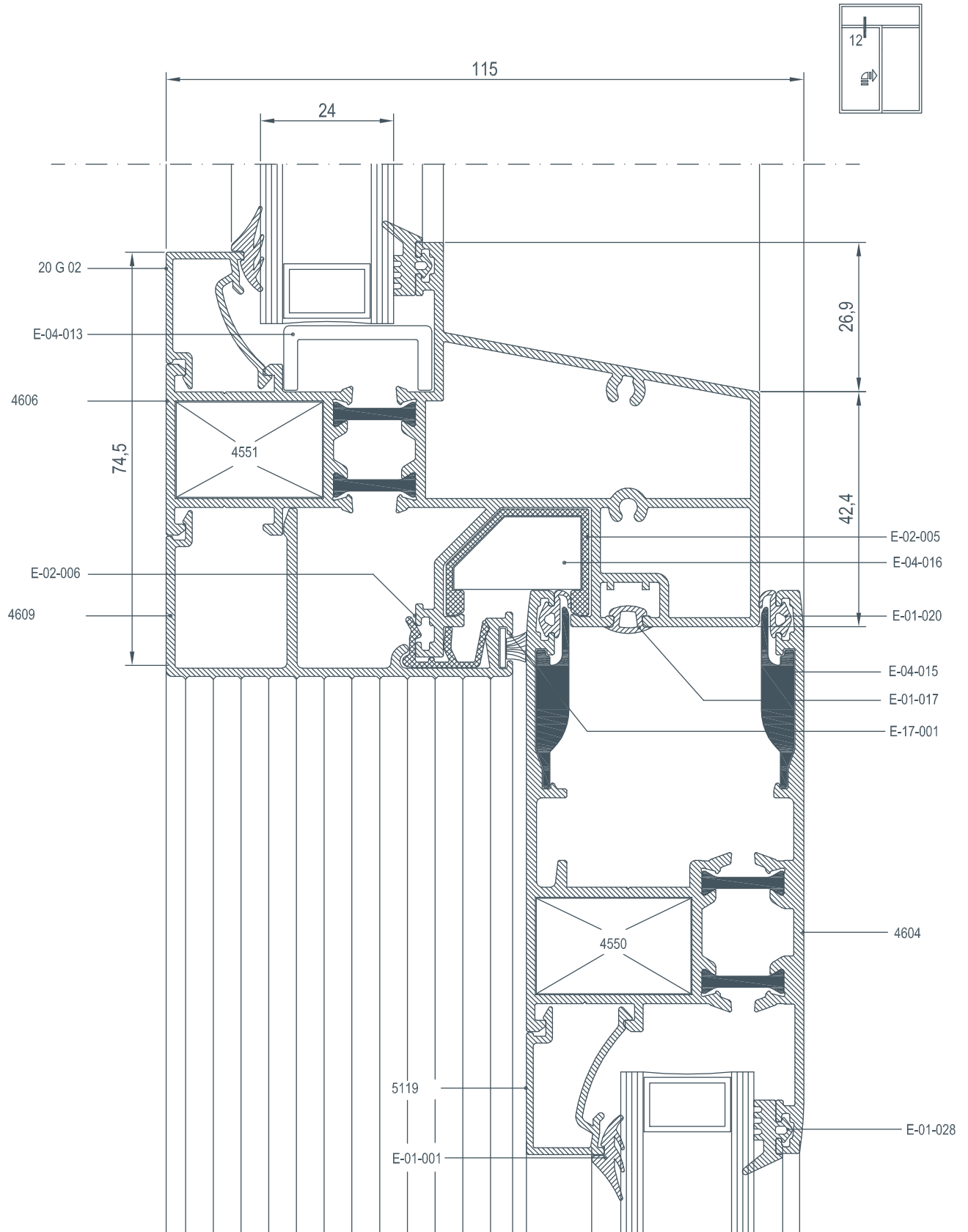

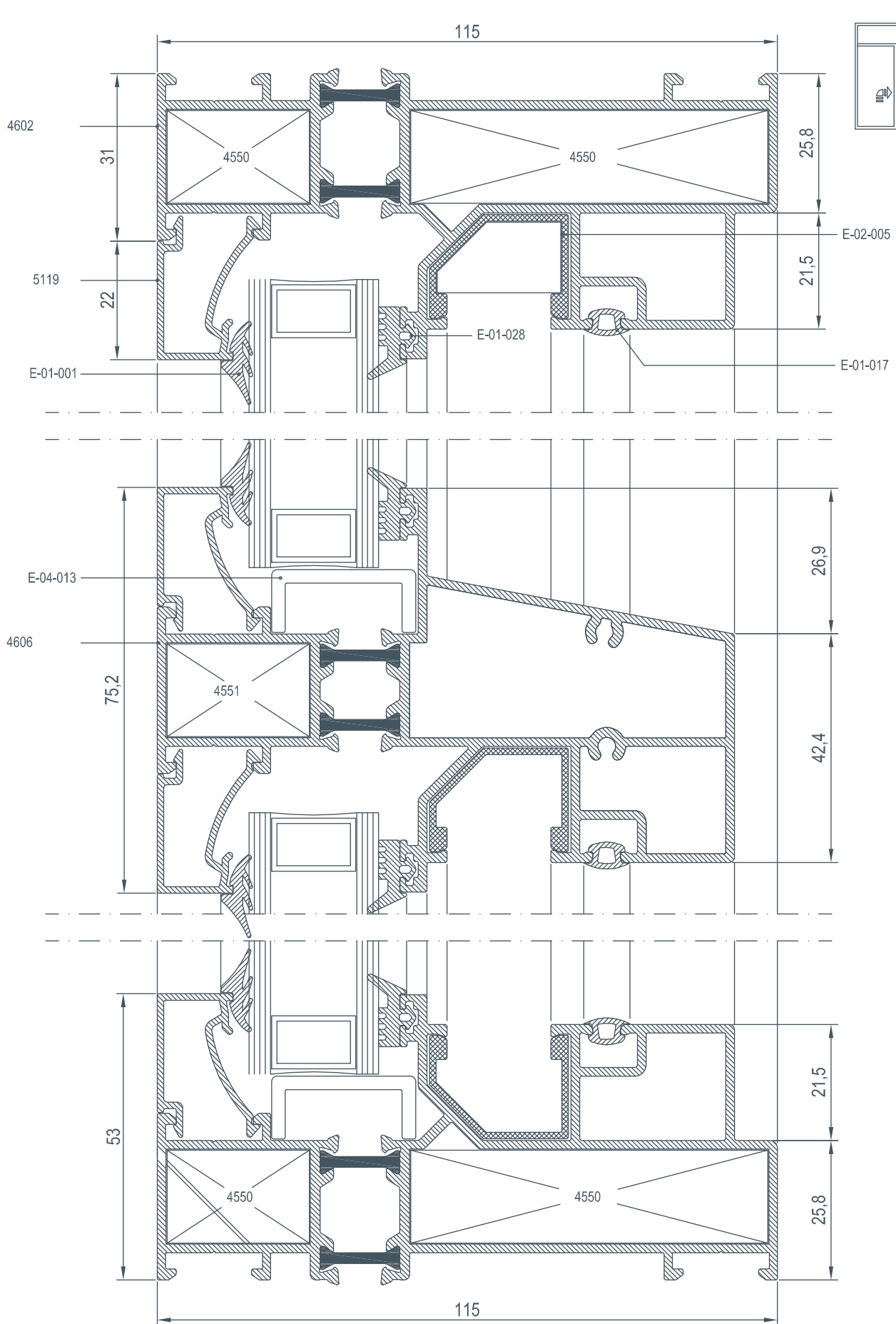









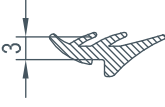
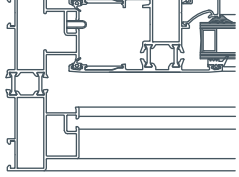

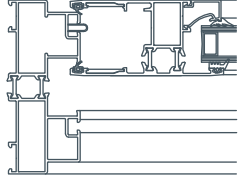
E 115

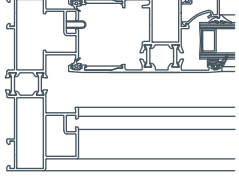
AKSESUARLAR
ACCESSORIES

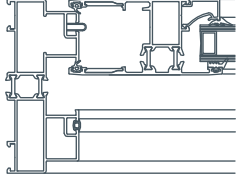

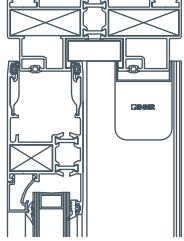
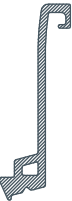
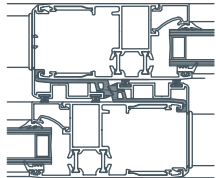



	<p>E-01-001 3mm iç cam fitili 3mm gasket 45 gr/mt</p>	
	<p>E-01-017 Bini Fitili Acoustical Gasket 27 gr/mt</p>	
	<p>E-01-028 4mm Dış cam fitili 4mm gasket 62 gr/mt</p>	
	<p>E-01-019 Ray Fitili Rail gasket 24 gr/mt</p>	
	<p>E-01-020 Üst Bini Fitili Acoustical Gasket 25 gr/mt</p>	
	<p>E-01-021 Kenet fitili Connection gasket 228 gr/mt</p>	

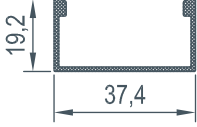
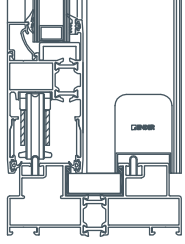
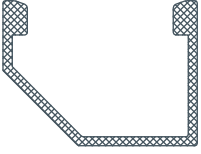
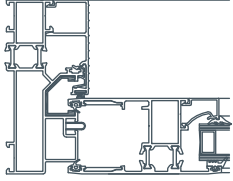

	<p>E-07-002 Kaldır-Sür Aksuarı Lift&Slide Accessories Wmax = 2120 mm H = 1751 mm ~ 2250 mm</p>	
	<p>E-04-011 Pvc Köşe Çavuşu Pvc Corner Cleat</p>	
	<p>E-16-003 Çelik Ray Steel Rail</p>	
	<p>E-04-014 Pvc Ray Kapağı PVC Vent Cap</p>	
	<p>E-04-015 PVC Seviyeleme Parçası PVC Balance Part</p>	
	<p>E-04-012 Sızdırmazlık Parçası Sealing Part EPDM</p>	

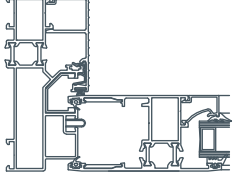
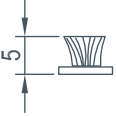
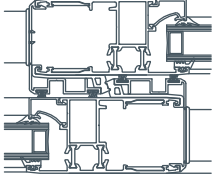

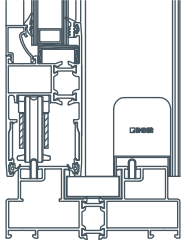
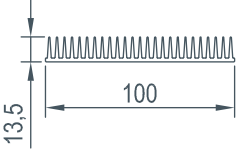
	<p>E-02-004</p> <p>PVC adaptör PVC adapter</p>	
	<p>E-02-005</p> <p>PVC adaptör PVC adapter</p>	
	<p>E-02-006</p> <p>PVC Kenet PVC Connector</p>	
	<p>E-17-001</p> <p>Kıl fitil Brush</p>	
	<p>E-04-013</p> <p>Cam Takozu Glass Wedge</p>	
	<p>E-04-016</p> <p>Sızdırmazlık Parçası Sealing Part EPDM</p>	