

**E1 - E2**

**E 55 - 1.8T (E1) - E55 - 1.5T (E2)**  
**YALITIMLI PENCERE VE KAPI SİSTEMLERİ**

*E 55 - 1.8T (E1) - E55 - 1.5T (E2)*  
*INSULATED WINDOWS & DOORS SYSTEMS*



**E 55**











| COD<br>Code | PROFİL KESİTİ<br>Profile View | PROFİL AÇIKLAMASI<br>Profile Description | AGIRLIK (kg/m)<br>Weight | Jxx cm <sup>4</sup> | Jyy cm <sup>4</sup> |
|-------------|-------------------------------|--|--------------------------|---------------------|---------------------|
| 5300        |                               | KASA PROFİLİ                             | 1,172                    | 15,20               | 3,62                |
| 5301        |                               | KASA PROFİLİ                             | 1,512                    | 20,31               | 9,95                |
| 5302        |                               | KASA PROFİLİ                             | 1,924                    | 21,73               | 32,90               |
| 5303        |                               | KANAT PROFİLİ                            | 1,446                    | 26,75               | 3,82                |
| 5304        |                               | KANAT PROFİLİ                            | 1,785                    | 35,34               | 11,45               |
| 5564        |                               | İÇE AÇILIR KAPI KANAT PRF.               | 2,500                    | 24,10               | 75,25               |
| 5306        |                               | DIŞA AÇILIR KAPI KANAT PRF.              | 2,310                    | 37,50               | 48,47               |
| 5307        |                               | ORTA KAYIT PROFİLİ                       | 1,344                    | 16,78               | 7,96                |
| 5308        |                               | ORTA KAYIT PROFİLİ                       | 1,684                    | 21,22               | 17,37               |
| 5309        |                               | ORTA KAYIT PROFİLİ                       | 2,096                    | 27,04               | 39,90               |
| 5310        |                               | ORTA KAYIT PROFİLİ                       | 1,756                    | 22,50               | 17,70               |



**E1 - E2**

| COD<br>Code | PROFİL KESİTİ<br>Profile View | PROFİL AÇIKLAMASI<br>Profile Description | AGIRLIK (kg/m)<br>Weight | Jxx cm <sup>4</sup> | Jyy cm <sup>4</sup> |
|-------------|-------------------------------|--|--------------------------|---------------------|---------------------|
| 5311        |                               | TAKV.ORTA KAYIT PROFİLİ                  | 2,398                    | 82,25               | 29,33               |
| 5312        |                               | TAKV.ORTA KAYIT PROFİLİ                  | 2,600                    | 127,17              | 26,77               |
| 5313        |                               | ETEK PROFİLİ                             | 2,505                    | 85,03               | 35,09               |
| 5314        |                               | ÇİFT KANAT ADAPTÖR PROF.                 | 1,404                    | 16,21               | 8,33                |
| 5315        |                               | PİVOT ADAPTÖR PROFİLİ                    | 1,488                    | 20,02               | 10,32               |
| 5316        |                               | KÖŞE DÖNÜŞ PROFİLİ                       | 1,987                    | 34,29               | 40,77               |
| 5117        |                               | TİJ PROFİLİ                              | 0,105                    | ---                 | ---                 |
| 5572        |                               | TİJ PROFİLİ<br>(BOYALI PROFİLLER İÇİN)   | 0,100                    | ---                 | ---                 |
| 5118        |                               | CAM ÇİTASI PROFİLİ                       | 0,249                    | ---                 | ---                 |
| 5119        |                               | CAM ÇİTASI PROFİLİ                       | 0,251                    | ---                 | ---                 |
| 5120        |                               | CAM ÇİTASI PROFİLİ                       | 0,255                    | ---                 | ---                 |

| COD<br>Code | PROFİL KESİTİ<br>Profile View   | PROFİL AÇIKLAMASI<br>Profile Description | AGIRLIK (kg/m)<br>Weight | Jxx cm <sup>4</sup> | Jyy cm <sup>4</sup> |
|-------------|---|--|--------------------------|---------------------|---------------------|
| 5121        |    | CAM ÇİTASI PROFİLİ                       | 0,260                    | ---                 | ---                 |
| 5122        |    | CAM ÇİTASI PROFİLİ                       | 0,267                    | ---                 | ---                 |
| 5123        |    | CAM ÇİTASI PROFİLİ                       | 0,274                    | ---                 | ---                 |
| 5124        |    | CAM ÇİTASI PROFİLİ                       | 0,281                    | ---                 | ---                 |
| 5125        |  | CAM ÇİTASI PROFİLİ                       | 0,292                    | ---                 | ---                 |
| 5526        |  | CAM ÇİTASI PROFİLİ                       | 0,308                    | ---                 | ---                 |
| 5535        |  | CAM ÇİTASI PROFİLİ                       | 0,305                    | ---                 | ---                 |
| 5536        |  | CAM ÇİTASI PROFİLİ                       | 0,312                    | ---                 | ---                 |
| 5537        |  | CAM ÇİTASI PROFİLİ                       | 0,318                    | ---                 | ---                 |
| 5538        |  | CAM ÇİTASI PROFİLİ                       | 0,325                    | ---                 | ---                 |
| 5539        |  | CAM ÇİTASI PROFİLİ                       | 0,331                    | ---                 | ---                 |



| COD<br>Code | PROFİL KESİTİ<br>Profile View | PROFİL AÇIKLAMASI<br>Profile Description | AGIRLIK (kg/m)<br>Weight | Jxx cm <sup>4</sup> | Jyy cm <sup>4</sup> |
|-------------|-------------------------------|--|--------------------------|---------------------|---------------------|
| 5317        |                               | KASA PROFİLİ                             | 1,111                    | 14,13               | 3,50                |
| 5318        |                               | KASA PROFİLİ                             | 1,427                    | 18,68               | 9,50                |
| 5319        |                               | KASA PROFİLİ                             | 1,807                    | 19,90               | 30,76               |
| 5320        |                               | KANAT PROFİLİ                            | 1,363                    | 24,59               | 3,60                |
| 5321        |                               | KANAT PROFİLİ                            | 1,656                    | 32,15               | 10,34               |
| 5567        |                               | İÇE AÇILIR KAPI KANAT PRF.               | 2,334                    | 30,84               | 71,09               |
| 5323        |                               | DIŞA AÇILIR KAPI KANAT PRF.              | 2,128                    | 33,18               | 44,54               |
| 5324        |                               | ORTA KAYIT PROFİLİ                       | 1,275                    | 15,62               | 7,63                |
| 5325        |                               | ORTA KAYIT PROFİLİ                       | 1,588                    | 19,43               | 16,53               |
| 5326        |                               | ORTA KAYIT PROFİLİ                       | 1,970                    | 24,42               | 37,77               |
| 5327        |                               | ORTA KAYIT PROFİLİ                       | 1,667                    | 20,77               | 16,89               |



| COD<br>Code | PROFİL KESİTİ<br>Profile View | PROFİL AÇIKLAMASI<br>Profile Description | AGIRLIK (kg/m)<br>Weight | Jxx cm <sup>4</sup> | Jyy cm <sup>4</sup> |
|-------------|-------------------------------|--|--------------------------|---------------------|---------------------|
| 5328        |                               | TAKV.ORTA KAYIT PROFİLİ                  | 2,188                    | 72,24               | 26,66               |
| 5329        |                               | TAKV.ORTA KAYIT PROFİLİ                  | 2,381                    | 115,43              | 24,50               |
| 5330        |                               | ETEK PROFİLİ                             | 2,314                    | 77,44               | 30,91               |
| 5331        |                               | ÇİFT KANAT ADAPTÖR PROF.                 | 1,300                    | 15,42               | 7,70                |
| 5332        |                               | PİVOT ADAPTÖR PROFİLİ                    | 1,379                    | 18,45               | 9,23                |
| 5333        |                               | İSPANYOLET PENCERE KANADI                | 2,005                    | 42,51               | 15,98               |
| 5334        |                               | İSPANYOLET KAPI KANADI                   | 2,567                    | 35,07               | 74,37               |
| 5335        |                               | DIŞA AÇILIR KAPI ADAPTÖRÜ                | 1,142                    | 12,13               | 5,23                |
| 5336        |                               | KÖŞE DÖNÜŞ ADAPRÖRÜ                      | 1,098                    | 8,33                | 7,71                |
| 5337        |                               | ADAPTÖR PROFİLİ                          | 0,151                    | ---                 | ---                 |
| 5338        |                               | ADAPTÖR PROFİLİ                          | 0,258                    | ---                 | ---                 |



**E1 - E2**

| COD<br>Code | PROFİL KESİTİ<br>Profile View | PROFİL AÇIKLAMASI<br>Profile Description | AGIRLIK (kg/m)<br>Weight | Jxx cm <sup>4</sup> | Jyy cm <sup>4</sup> |
|-------------|-------------------------------|--|--------------------------|---------------------|---------------------|
| 5339        |                               | ADAPTÖR PROFİLİ                          | 0,374                    | ---                 | ---                 |
| 5127        |                               | KÖŞE TAKOZ PROFİLİ                       | 3,484                    | ---                 | ---                 |
| 5128        |                               | KÖŞE TAKOZ PROFİLİ                       | 3,652                    | ---                 | ---                 |
| 5129        |                               | KÖŞE TAKOZ PROFİLİ                       | 4,618                    | ---                 | ---                 |
| 5570        |                               | " U " BAĞ. PROFİLİ                       | 0,393                    | ---                 | ---                 |
| 5569        |                               | " U " BAĞ. PROFİLİ                       | 0,555                    | ---                 | ---                 |
| 5571        |                               | " U " BAĞ. PROFİLİ                       | 0,772                    | ---                 | ---                 |
| 4542        |                               | KÖŞE TAKOZ PROFİLİ                       | 5,381                    | ---                 | ---                 |





**E 55**

**E1**

---

# **PROFİLLER** *PROFILES*

---

E 55 - 1.8T (E1) YALITIMLI SERİ  
*E 55 - 1.8T (E1) INSULATION SERIES*



| COD<br>Code | AGIRLIK (kg/m)<br>Weight | Jxx cm <sup>4</sup> | Jyy cm <sup>4</sup> | L m |
|-------------|--------------------------|---------------------|---------------------|-----|
| 5300        | 1,172                    | 15,20               | 3,62                | 6   |
| 5301        | 1,512                    | 20,31               | 9,95                | 6   |
| 5302        | 1,924                    | 21,73               | 32,90               | 6   |

5300

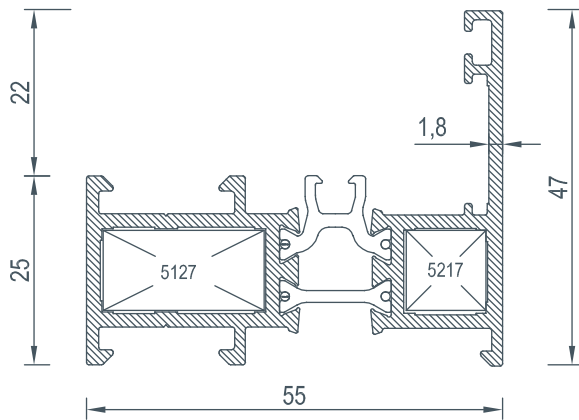

5302

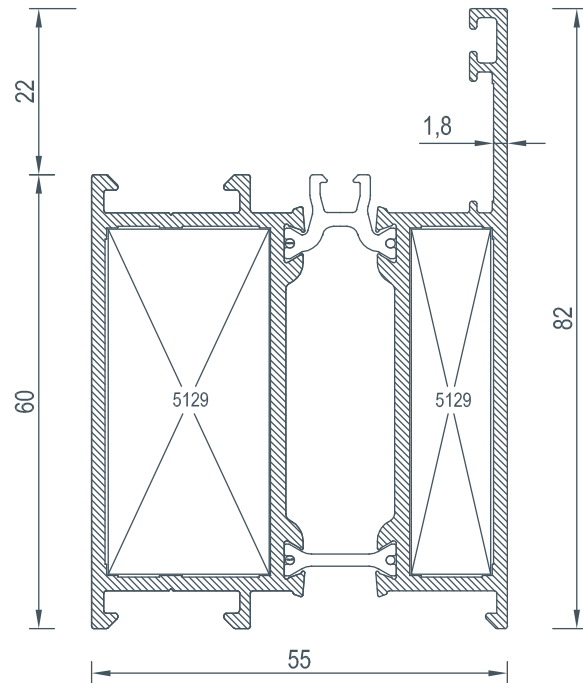

5301

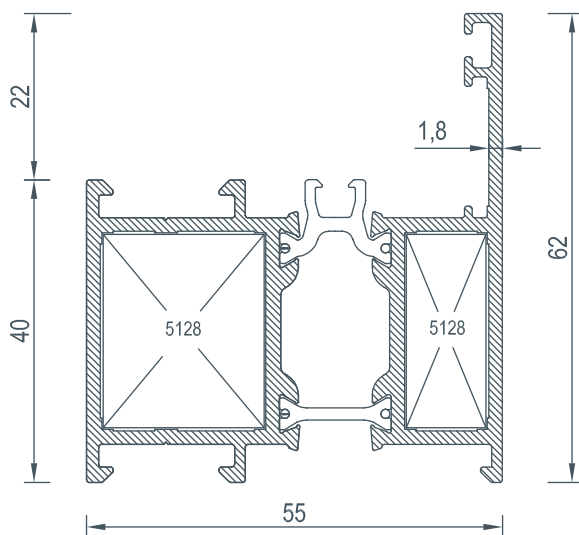



| COD<br>Code | AGIRLIK (kg/m)<br>Weight | Jxx cm <sup>4</sup> | Jyy cm <sup>4</sup> | L m |
|-------------|--------------------------|---------------------|---------------------|-----|
| 5303        | 1,446                    | 26,75               | 3,82                | 6   |
| 5304        | 1,784                    | 35,34               | 11,45               | 6   |

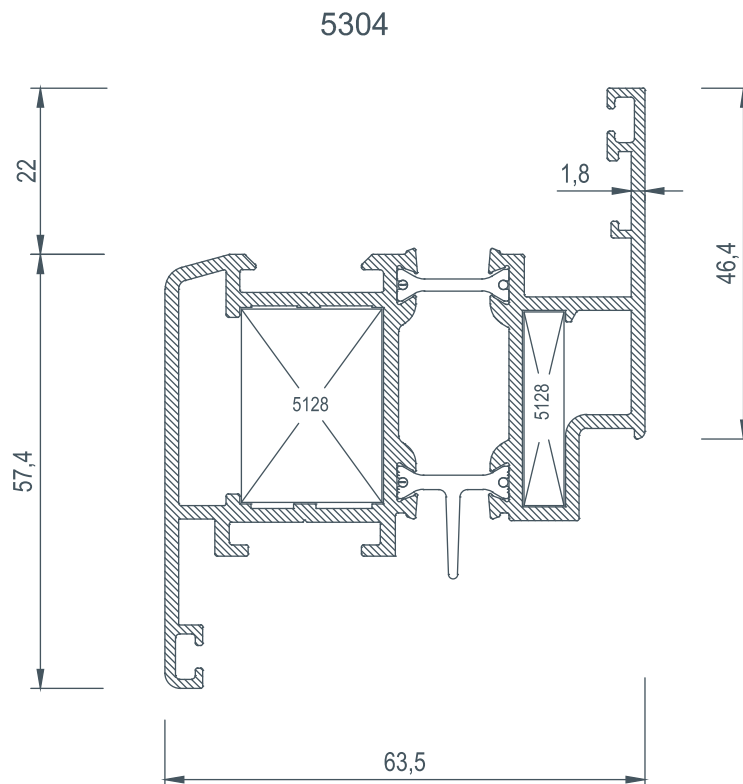
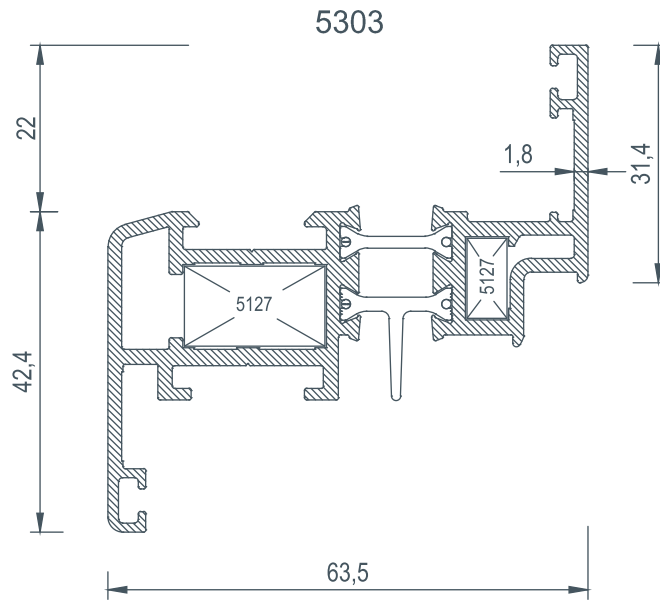

| COD<br>Code | AGIRLIK (kg/m)<br>Weight | Jxx cm4 | Jyy cm4 | L m |
|-------------|--------------------------|---------|---------|-----|
| 5333        | 2,005                    | 42,51   | 15,98   | 6   |
| 5334        | 2,567                    | 35,07   | 74,37   | 6   |

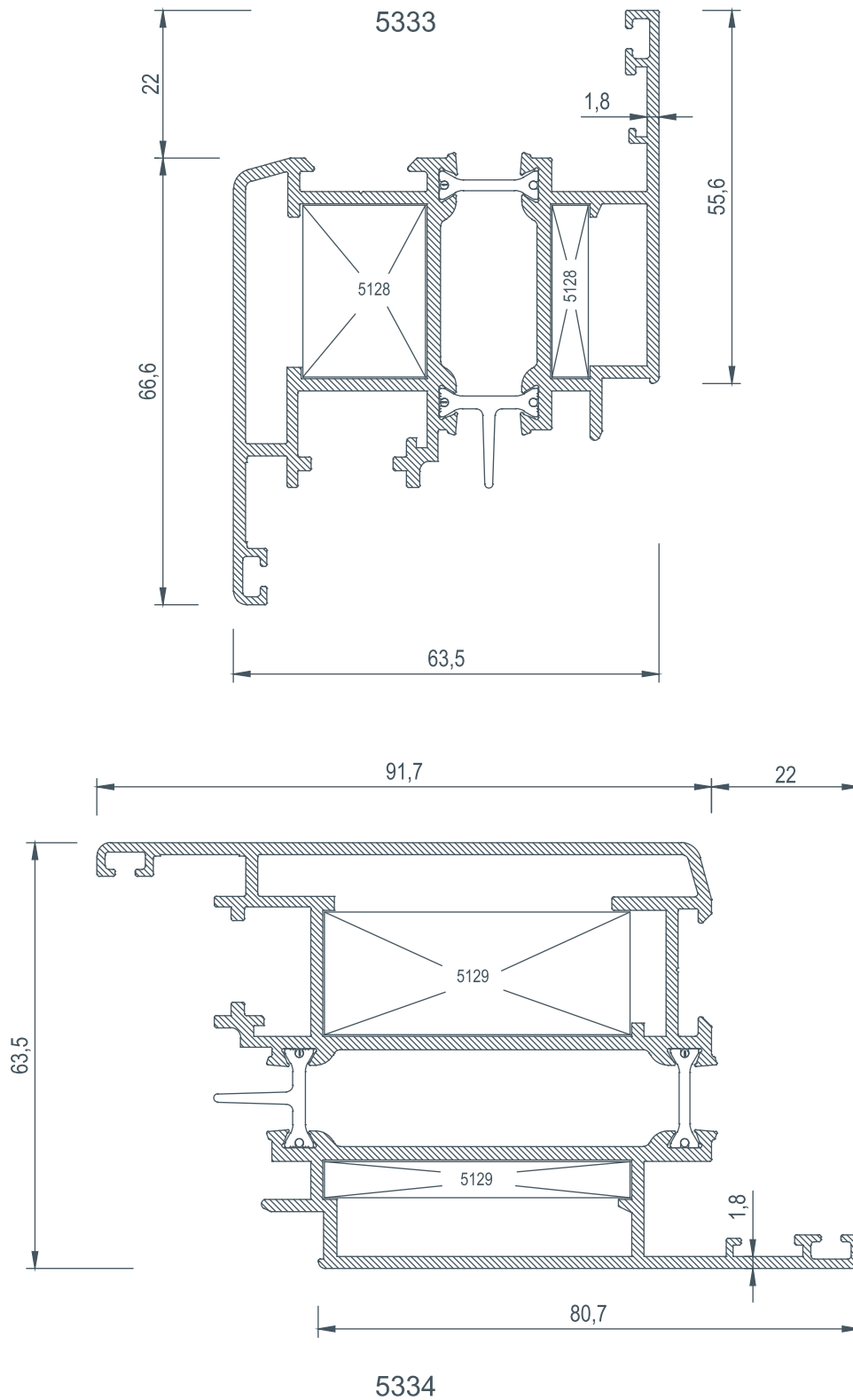

| COD<br>Code | AGIRLIK (kg/m)<br>Weight | Jxx cm <sup>4</sup> | Jyy cm <sup>4</sup> | L m |
|-------------|--------------------------|---------------------|---------------------|-----|
| 5564        | 2,498                    | 35,02               | 75,25               | 6   |
| 5306        | 2,308                    | 37,50               | 48,47               | 6   |

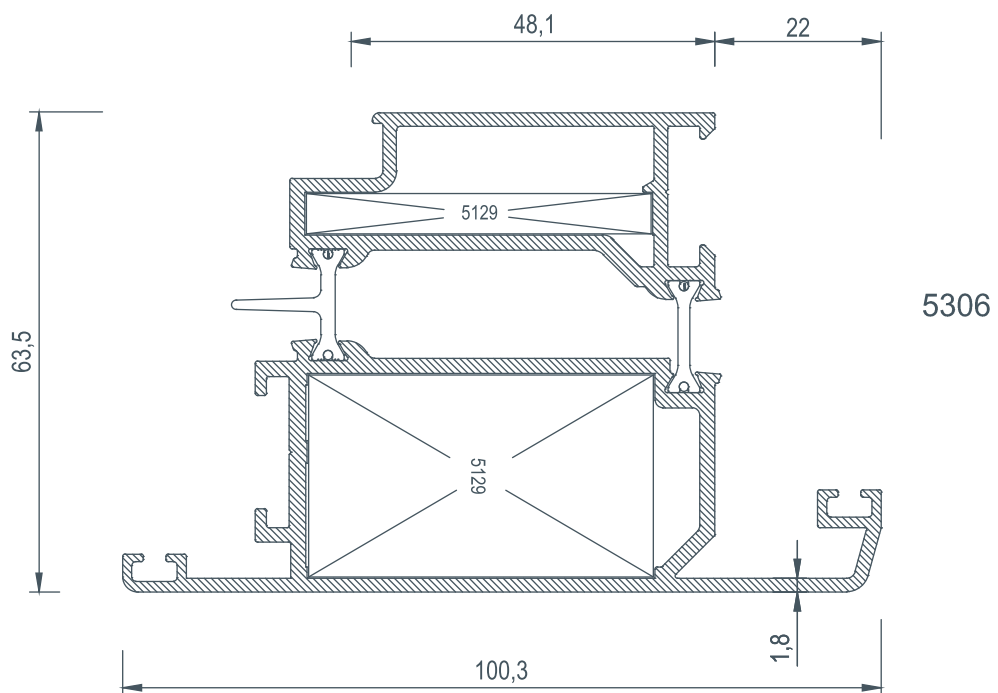
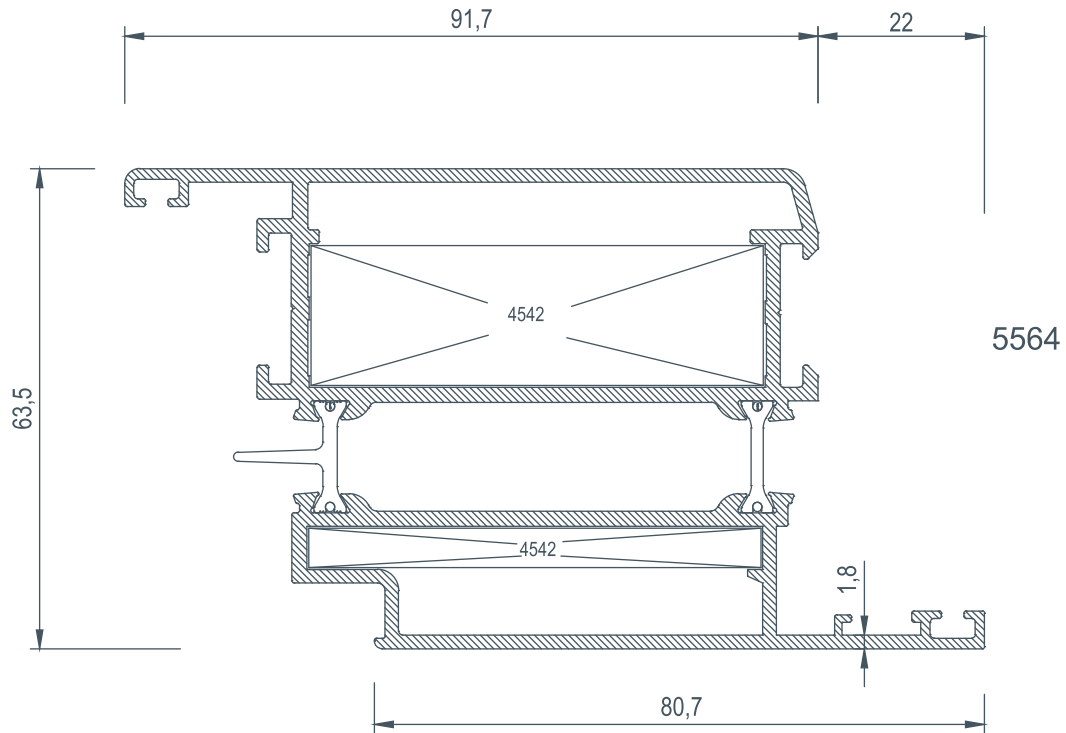



| COD<br>Code | AGIRLIK (kg/m)<br>Weight | Jxx cm <sup>4</sup> | Jyy cm <sup>4</sup> | L m<br>→ |
|-------------|--------------------------|---------------------|---------------------|----------|
| 5307        | 1,344                    | 16,78               | 7,96                | 6        |
| 5308        | 1,684                    | 21,22               | 17,37               | 6        |
| 5309        | 2,096                    | 27,04               | 39,90               | 6        |
| 5310        | 1,756                    | 22,50               | 17,70               | 6        |

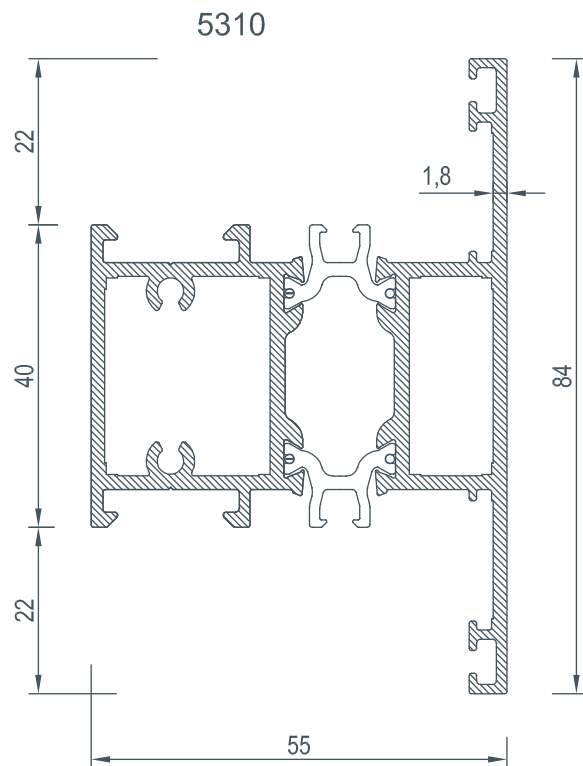
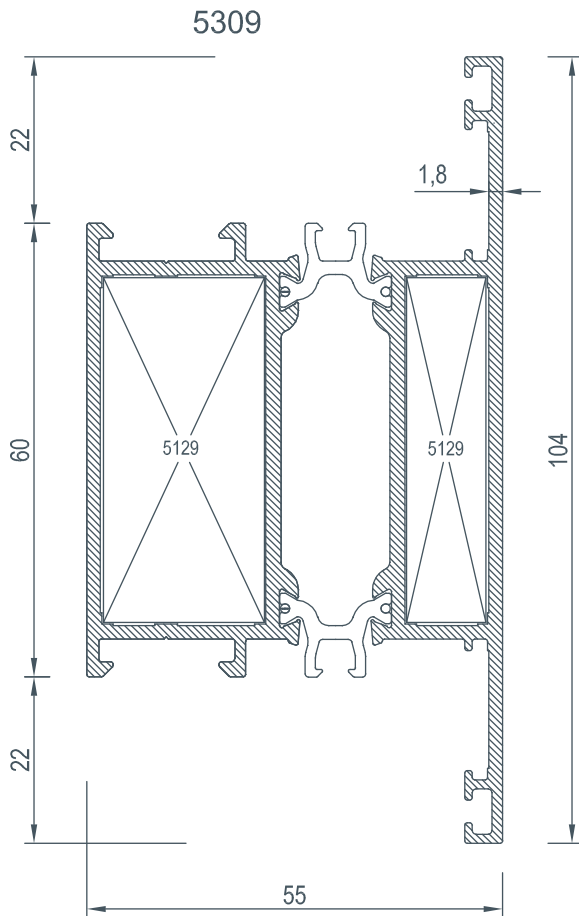
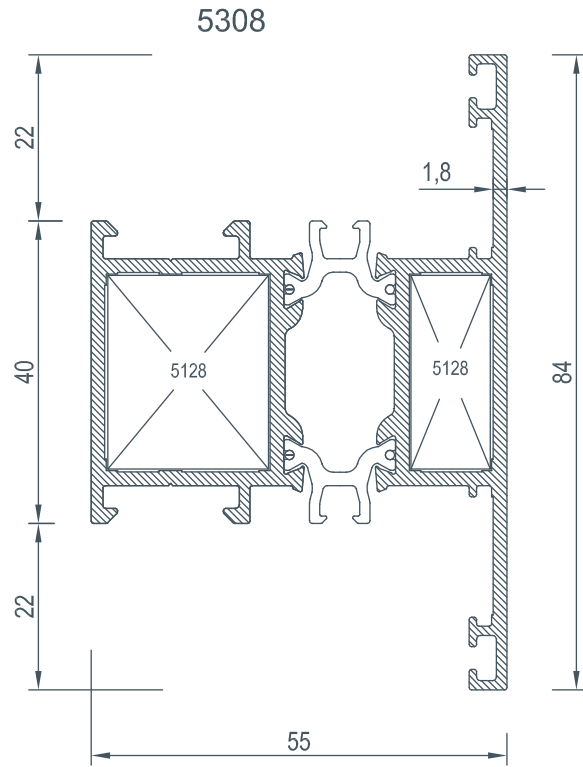
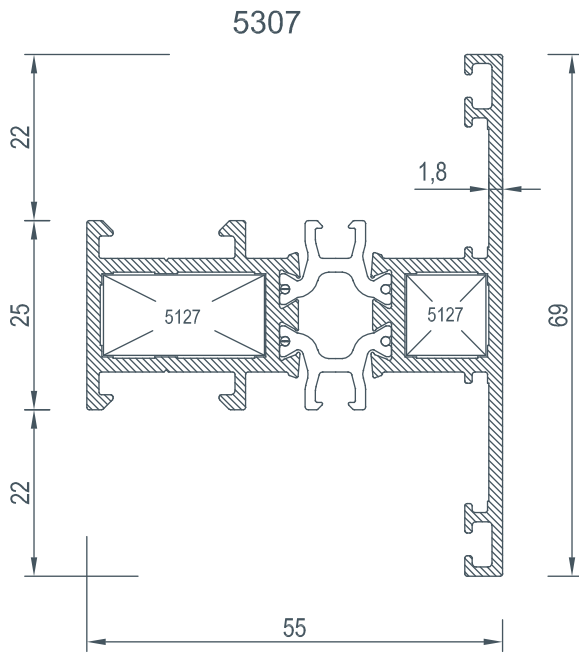

| COD<br>Code | AGIRLIK (kg/m)<br>Weight | Jxx cm <sup>4</sup> | Jyy cm <sup>4</sup> | L m<br>→ |
|-------------|--------------------------|---------------------|---------------------|----------|
| 5311        | 2,398                    | 82,25               | 29,33               | 6        |
| 5312        | 2,600                    | 127,17              | 26,77               | 6        |

5311

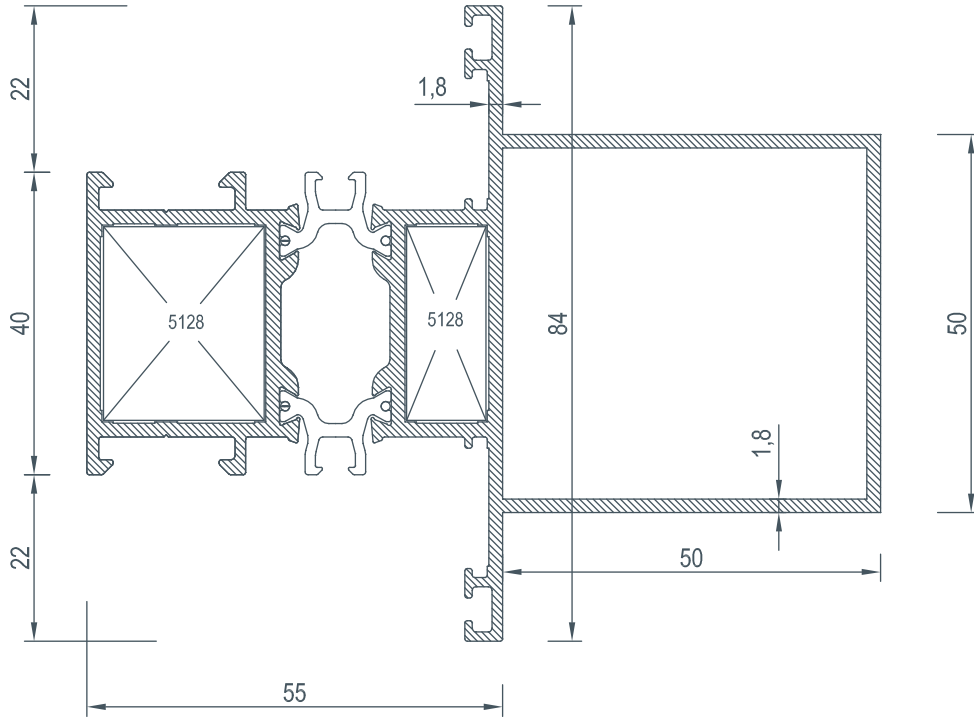

5312

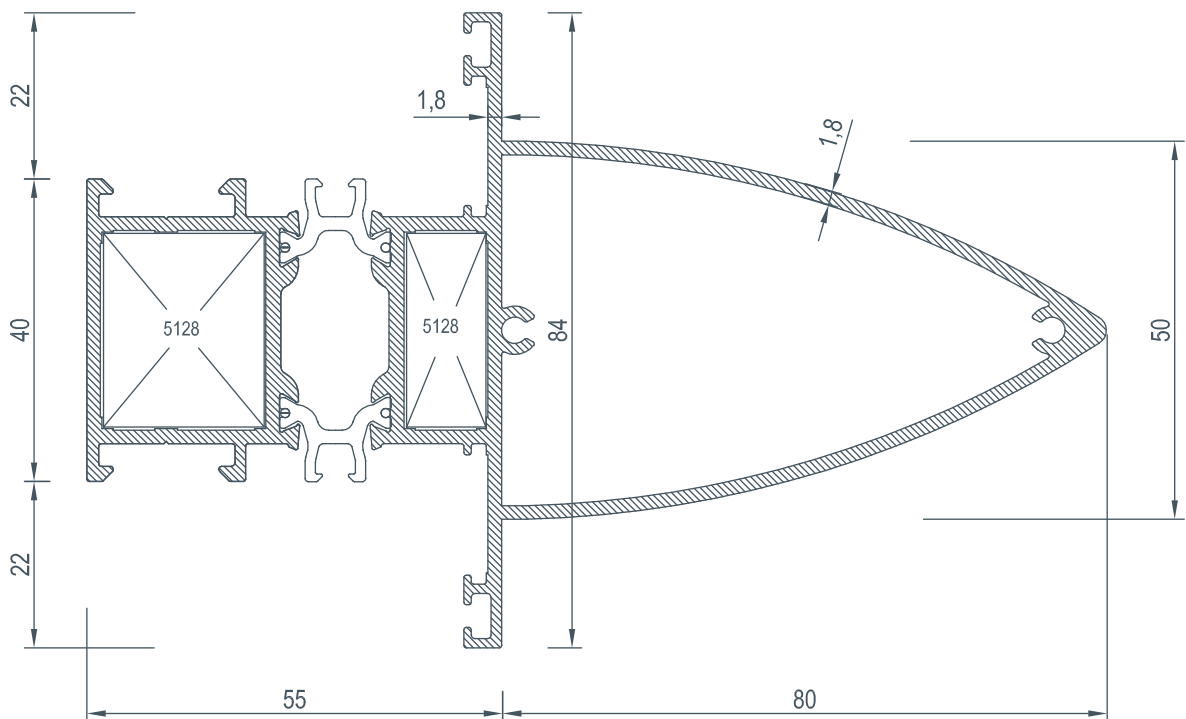





| COD<br>Code | AGIRLIK (kg/m)<br>Weight | Jxx cm <sup>4</sup> | Jyy cm <sup>4</sup> | L m |
|-------------|--------------------------|---------------------|---------------------|-----|
| 5313        | 2,505                    | 85,03               | 35,09               | 6   |

5313

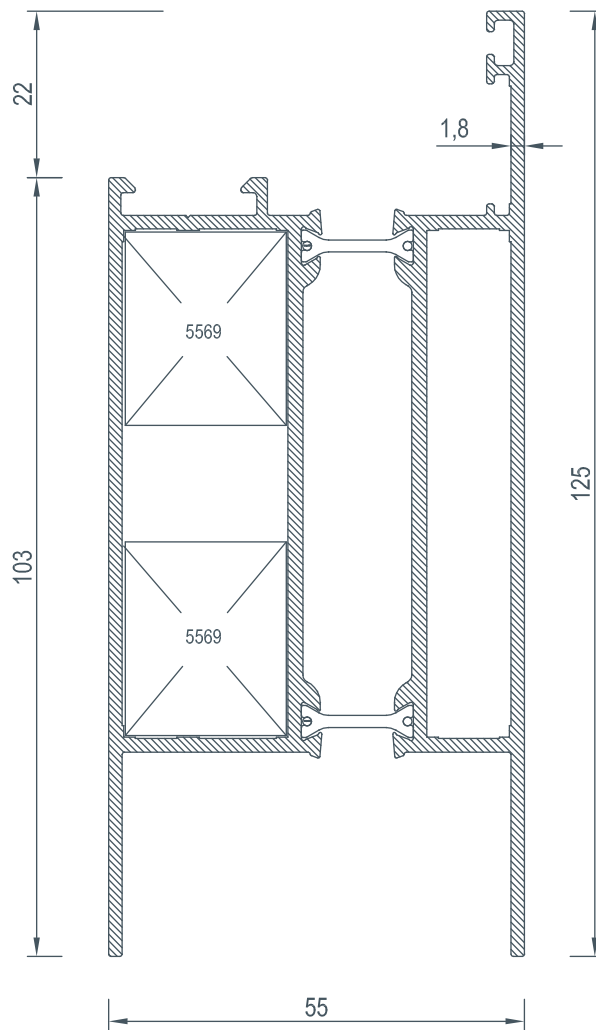

| COD<br>Code | AGIRLIK (kg/m)<br>Weight | Jxx cm <sup>4</sup> | Jyy cm <sup>4</sup> | L m<br>← → |
|-------------|--------------------------|---------------------|---------------------|------------|
| 5314        | 1,404                    | 16,21               | 8,33                | 6          |
| 5315        | 1,488                    | 20,02               | 10,32               | 6          |
| 5335        | 1,142                    | 12,13               | 5,23                | 6          |

5314

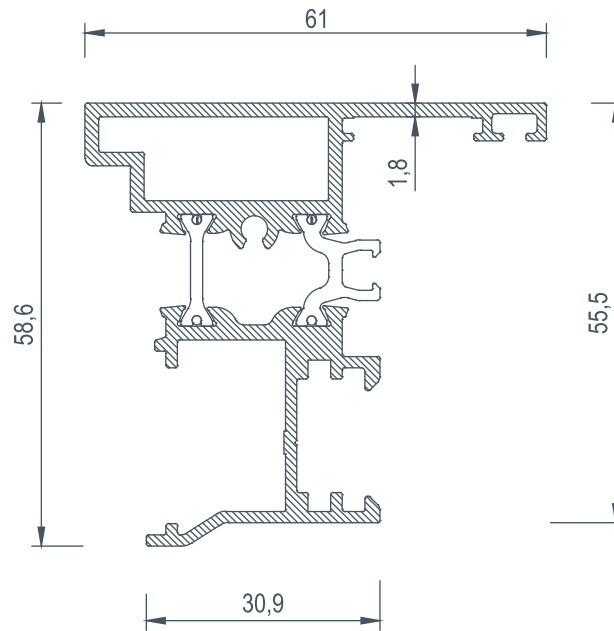

5315

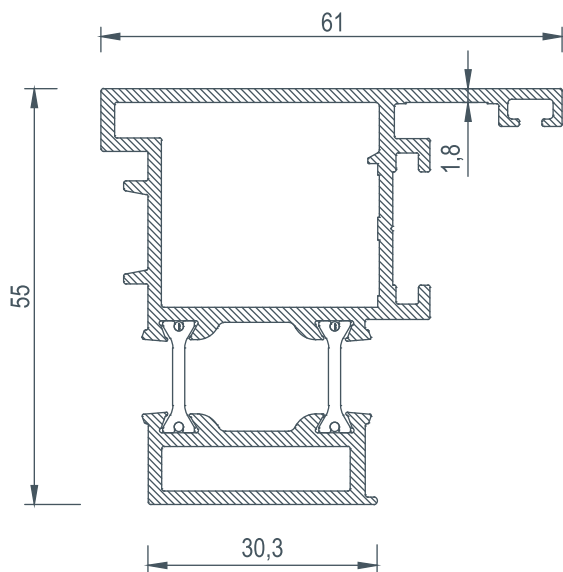

5335

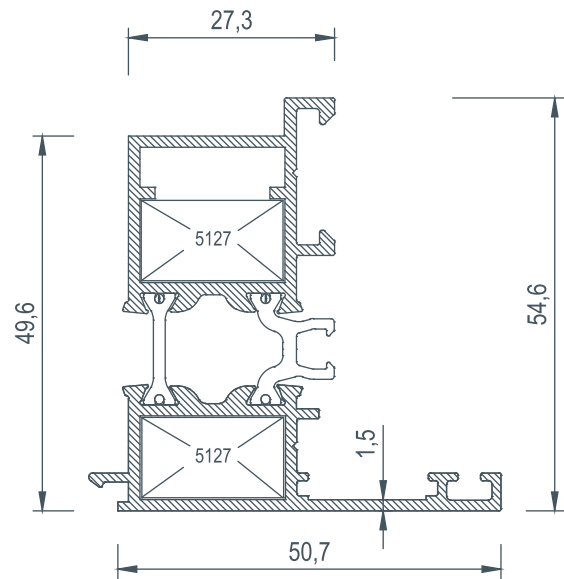



| COD<br>Code | AGIRLIK (kg/m)<br>Weight | Jxx cm <sup>4</sup> | Jyy cm <sup>4</sup> | L m<br>← → |
|-------------|--------------------------|---------------------|---------------------|------------|
| 5316        | 1,987                    | 34,29               | 40,77               | 6          |
| 5117        | 0,105                    | ---                 | ---                 | 6          |
| 5336        | 1,098                    | 8,33                | 7,71                | 6          |
| 5337        | 0,151                    | ---                 | ---                 | 6          |
| 5338        | 0,258                    | ---                 | ---                 | 6          |
| 5339        | 0,374                    | ---                 | ---                 | 6          |

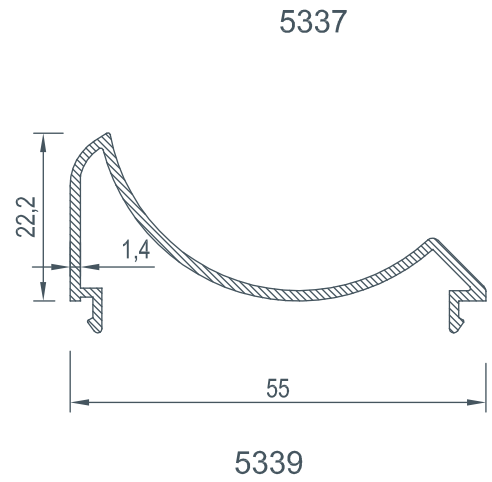
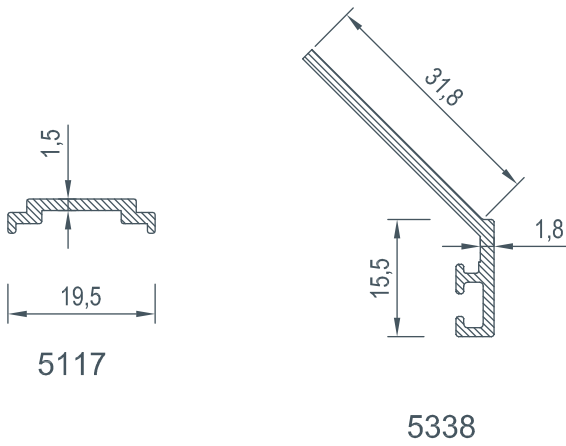
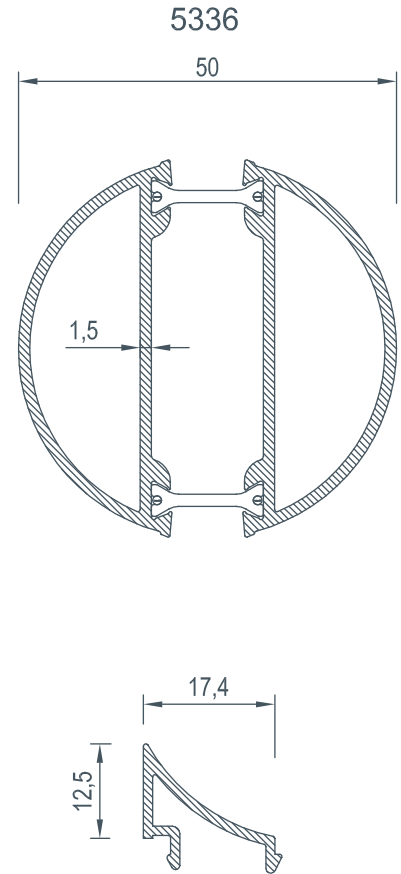
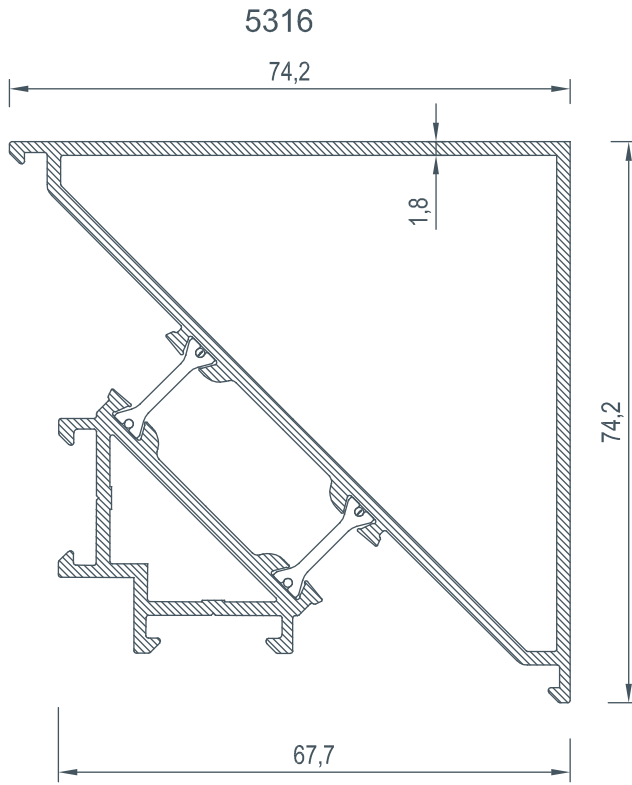



| COD<br>Code | AGIRLIK (kg/m)<br>Weight | Jxx cm4 | Jyy cm4 | L m |
|-------------|--------------------------|---------|---------|-----|
| 5118        | 0,249                    | -----   | -----   | 6   |
| 5119        | 0,251                    | -----   | -----   | 6   |
| 5120        | 0,254                    | -----   | -----   | 6   |
| 5121        | 0,259                    | -----   | -----   | 6   |
| 5122        | 0,267                    | -----   | -----   | 6   |
| 5123        | 0,274                    | -----   | -----   | 6   |
| 5124        | 0,281                    | -----   | -----   | 6   |
| 5125        | 0,292                    | -----   | -----   | 6   |
| 5126        | 0,308                    | -----   | -----   | 6   |
| 5535        | 0,305                    | -----   | -----   | 6   |

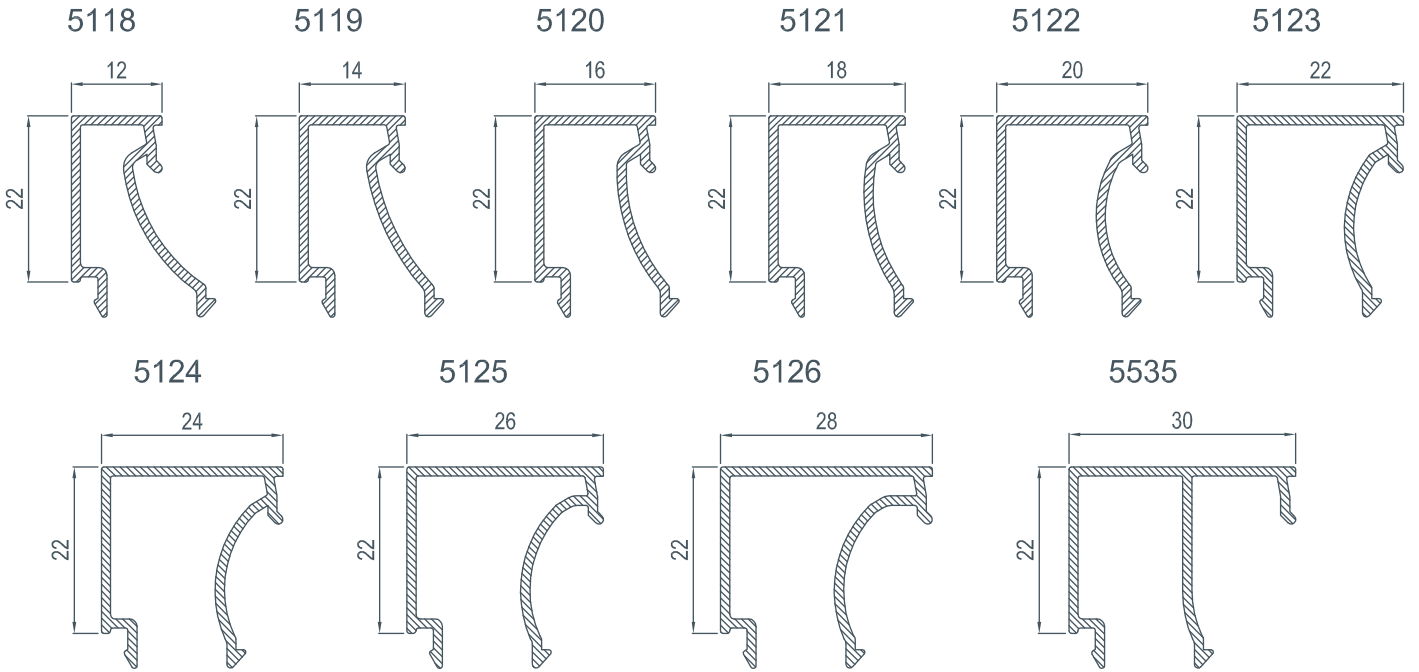

| CAM ÇİTASI<br>Glazing Bead | İÇ CAM FİTİLİ<br>Glazing Gasket (in) | CAM KALINLIĞI<br>Glas Thickness | DIŞ CAM FİTİLİ<br>Glazing Gasket (out) |
|----------------------------|--------------------------------------|---------------------------------|--|
| 5118                       | E-01-027                             | 30mm                            | E-01-028                               |
| 5119                       | E-01-027                             | 28mm                            | E-01-028                               |
| 5120                       | E-01-027                             | 26mm                            | E-01-028                               |
| 5121                       | E-01-027                             | 24mm                            | E-01-028                               |
| 5122                       | E-01-027                             | 22mm                            | E-01-028                               |
| 5123                       | E-01-027                             | 20mm                            | E-01-028                               |
| 5124                       | E-01-027                             | 18mm                            | E-01-028                               |
| 5125                       | E-01-027                             | 16mm                            | E-01-028                               |
| 5126                       | E-01-027                             | 14mm                            | E-01-028                               |
| 5535                       | E-01-027                             | 12mm                            | E-01-028                               |



| COD<br>Code | AGIRLIK (kg/m)<br>Weight | Jxx cm4 | Jyy cm4 | L m |
|-------------|--------------------------|---------|---------|-----|
| 5536        | 0,312                    | -----   | -----   | 6   |
| 5537        | 0,318                    | -----   | -----   | 6   |
| 5538        | 0,325                    | -----   | -----   | 6   |
| 5539        | 0,331                    | -----   | -----   | 6   |

5536

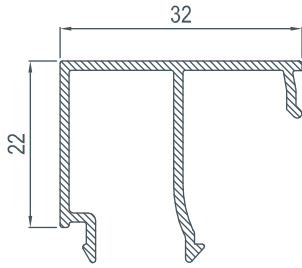

5537

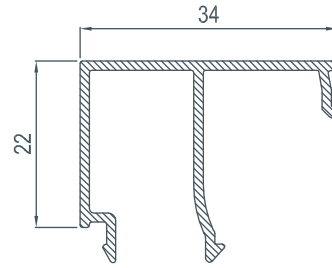

5538

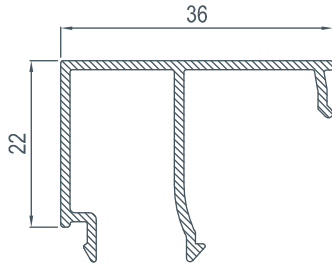

5539

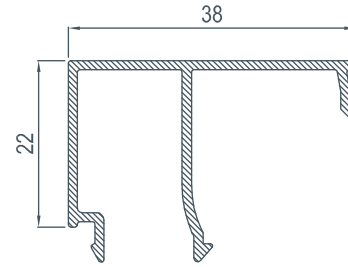

| CAM ÇİTASI<br>Glazing Bead | İÇ CAM FİTİLİ<br>Glazing Gasket (in) | CAM KALINLIĞI<br>Glas Thickness | DIŞ CAM FİTİLİ<br>Glazing Gasket (out) |
|----------------------------|--------------------------------------|---------------------------------|--|
| 5536                       | E-01-027                             | 10mm                            | E-01-028                               |
| 5537                       | E-01-027                             | 8mm                             | E-01-028                               |
| 5538                       | E-01-027                             | 6mm                             | E-01-028                               |
| 5539                       | E-01-027                             | 4mm                             | E-01-028                               |





**E 55**

**E2**

---

# **PROFILLER** *PROFILES*

---

EKONOMİK PROFİLLER E 55 - 1,5T (E2)  
*ECONOMIC PROFILES E 55 - 1,5T (E2)*







| COD<br>Code | AGIRLIK (kg/m)<br>Weight | Jxx cm <sup>4</sup> | Jyy cm <sup>4</sup> | L m<br>← → |
|-------------|--------------------------|---------------------|---------------------|------------|
| 5317        | 1,111                    | 14,13               | 3,50                | 6          |
| 5318        | 1,427                    | 18,68               | 9,50                | 6          |
| 5319        | 1,807                    | 19,90               | 30,76               | 6          |

5317

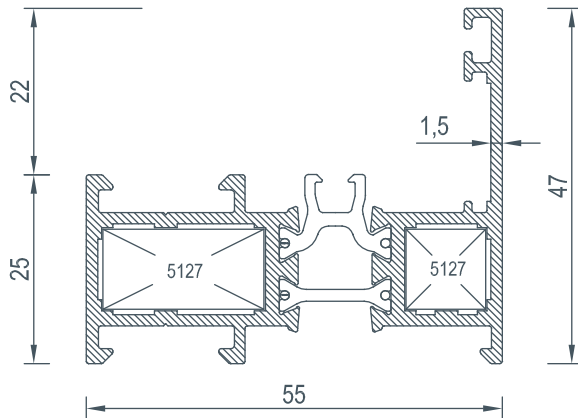

5319

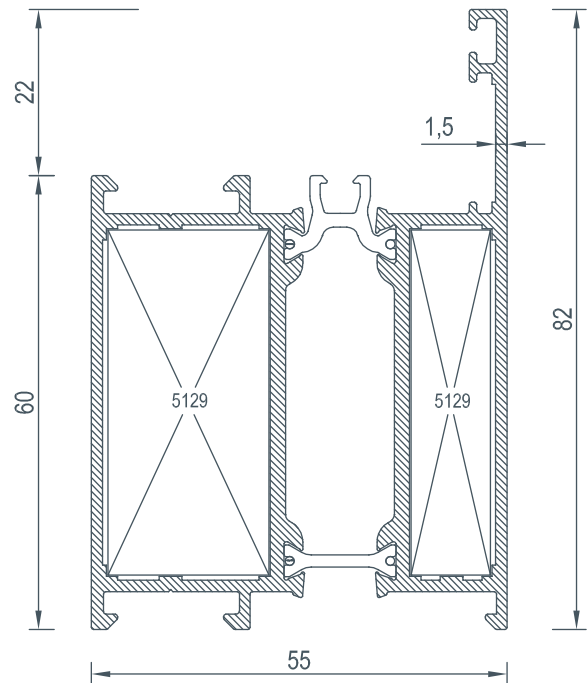

5318

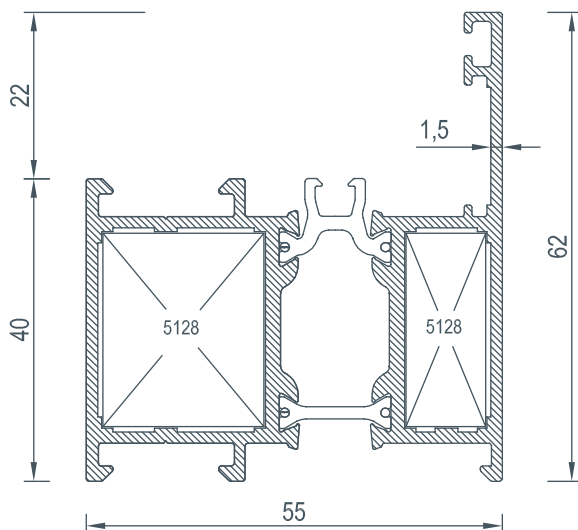



| COD<br>Code | AGIRLIK (kg/m)<br>Weight | Jxx cm <sup>4</sup> | Jyy cm <sup>4</sup> | L m<br>← → |
|-------------|--------------------------|---------------------|---------------------|------------|
| 5320        | 1,363                    | 24,59               | 3,60                | 6          |
| 5321        | 1,651                    | 32,15               | 10,34               | 6          |

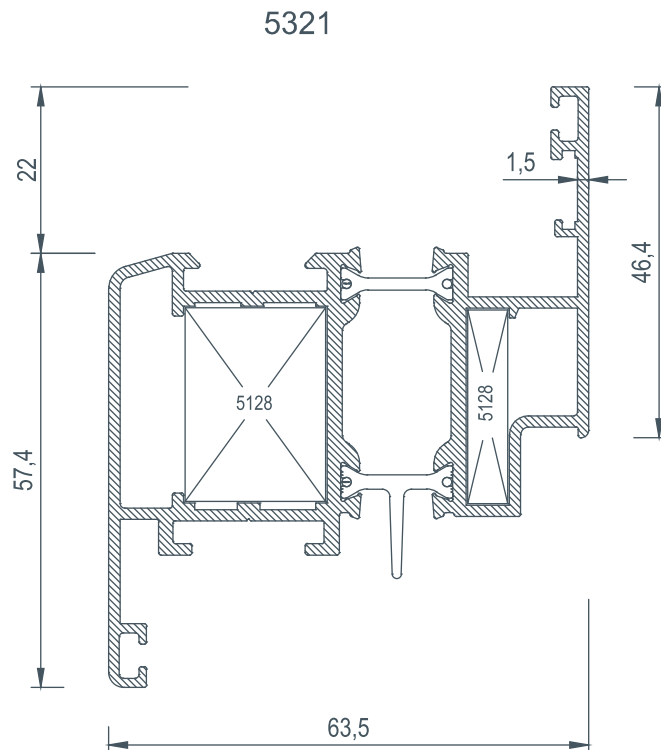
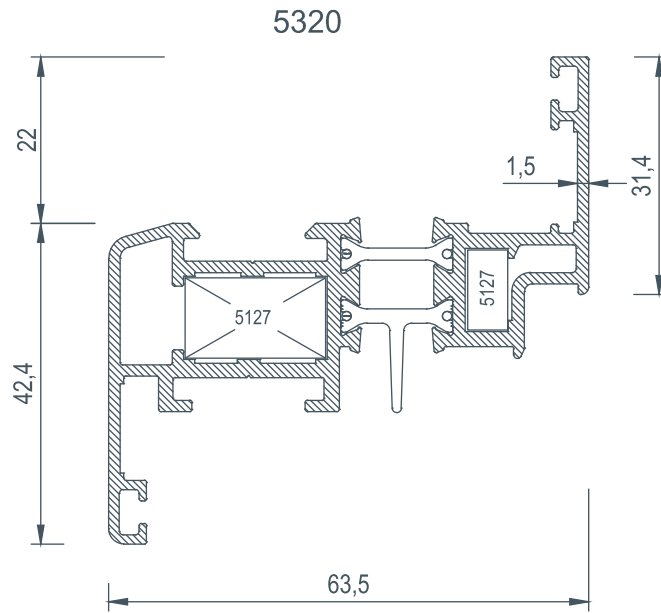

| COD<br>Code | AGIRLIK (kg/m)<br>Weight | Jxx cm4 | Jyy cm4 | L m |
|-------------|--------------------------|---------|---------|-----|
| 5333        | 2,005                    | 42,51   | 15,98   | 6   |
| 5334        | 2,567                    | 35,07   | 74,37   | 6   |

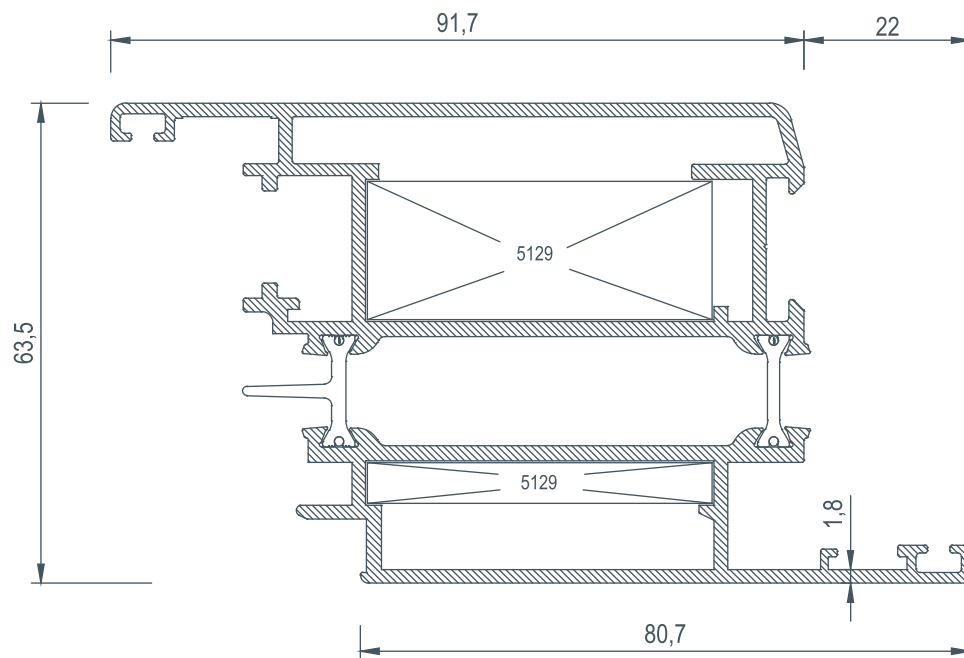
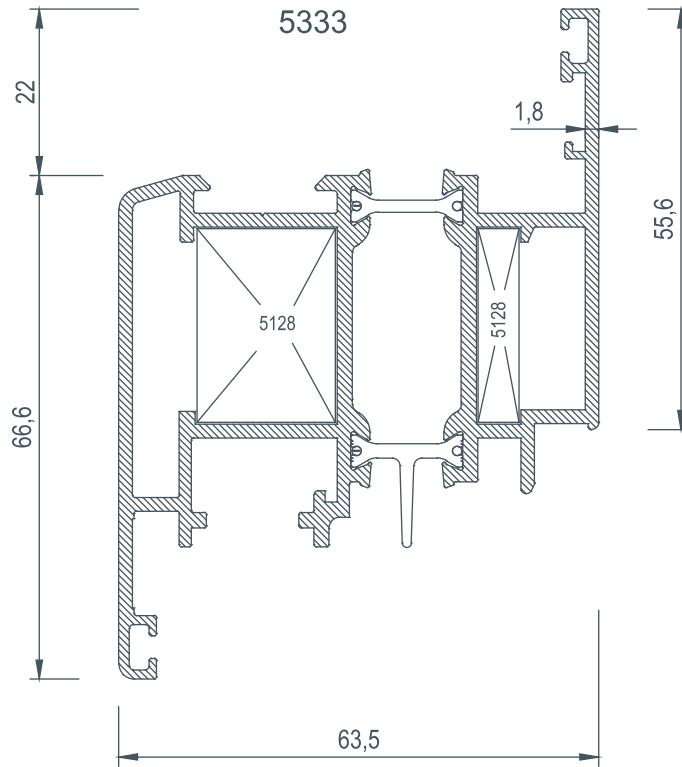

5334



| COD<br>Code | AGIRLIK (kg/m)<br>Weight | Jxx cm <sup>4</sup> | Jyy cm <sup>4</sup> | L m<br>← → |
|-------------|--------------------------|---------------------|---------------------|------------|
| 5567        | 2,331                    | 30,84               | 71,09               | 6          |
| 5323        | 2,127                    | 33,18               | 44,54               | 6          |

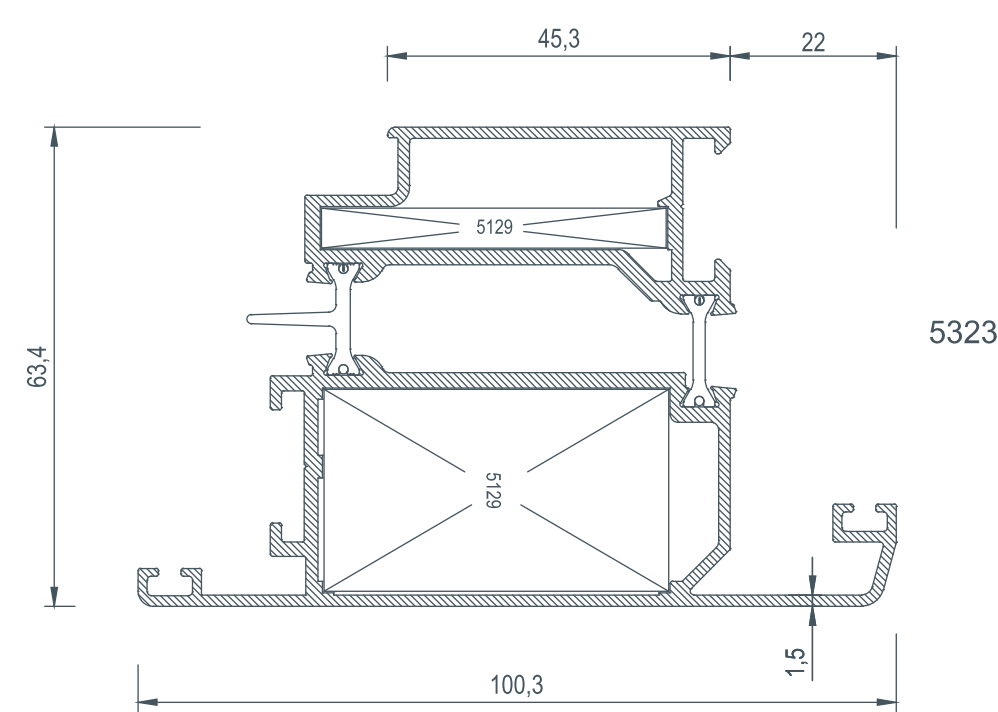
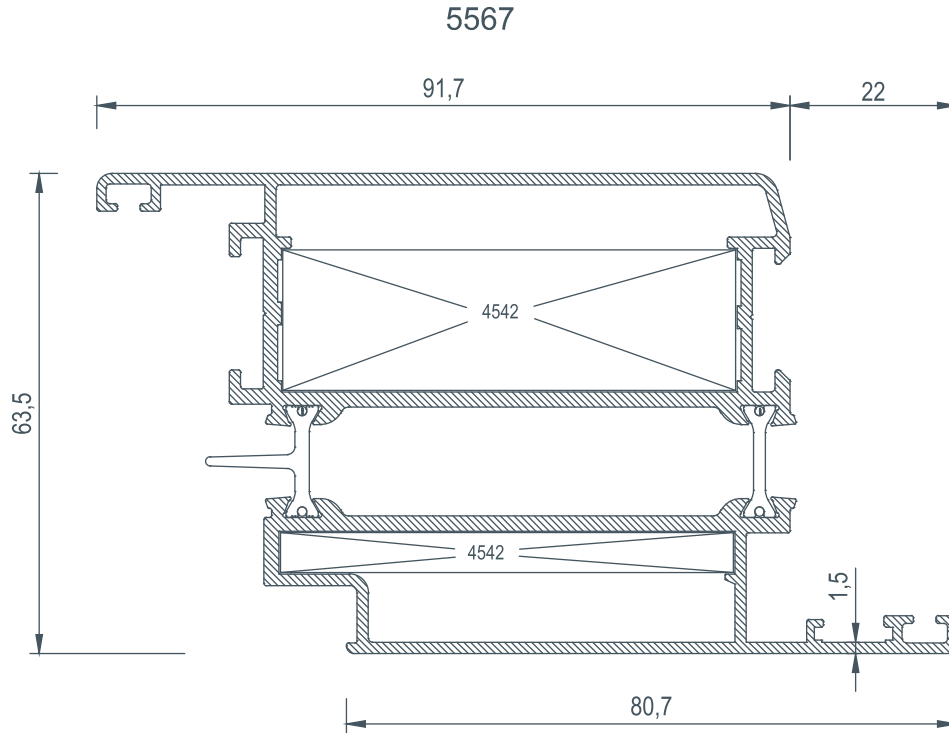



| COD<br>Code | AGIRLIK (kg/m)<br>Weight | Jxx cm4 | Jyy cm4 | L m<br>← → |
|-------------|--------------------------|---------|---------|------------|
| 5324        | 1,275                    | 15,62   | 7,63    | 6          |
| 5325        | 1,588                    | 19,43   | 16,53   | 6          |
| 5326        | 1,970                    | 24,42   | 37,77   | 6          |
| 5327        | 1,667                    | 20,77   | 16,89   | 6          |

5324

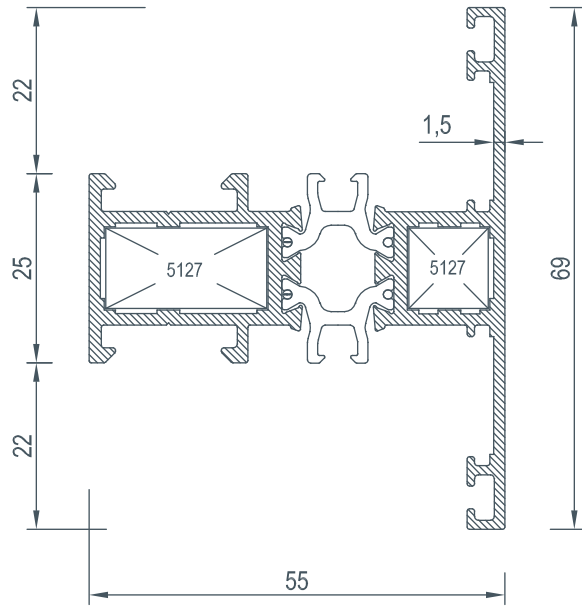

5325

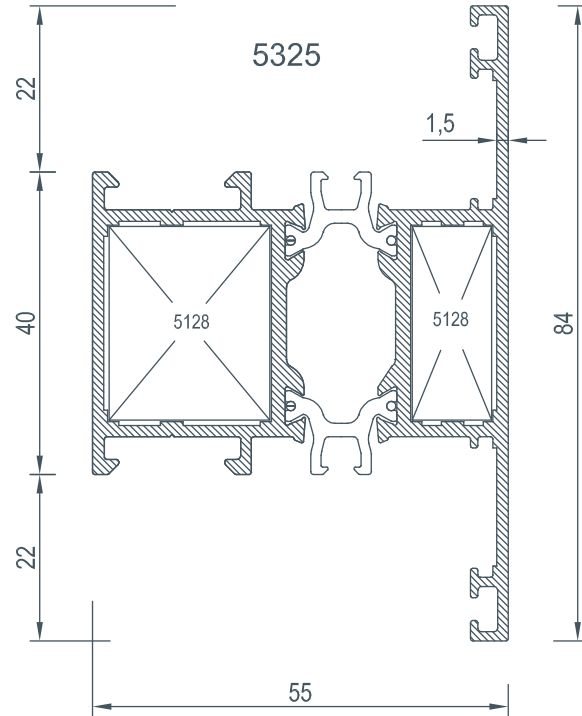

5326

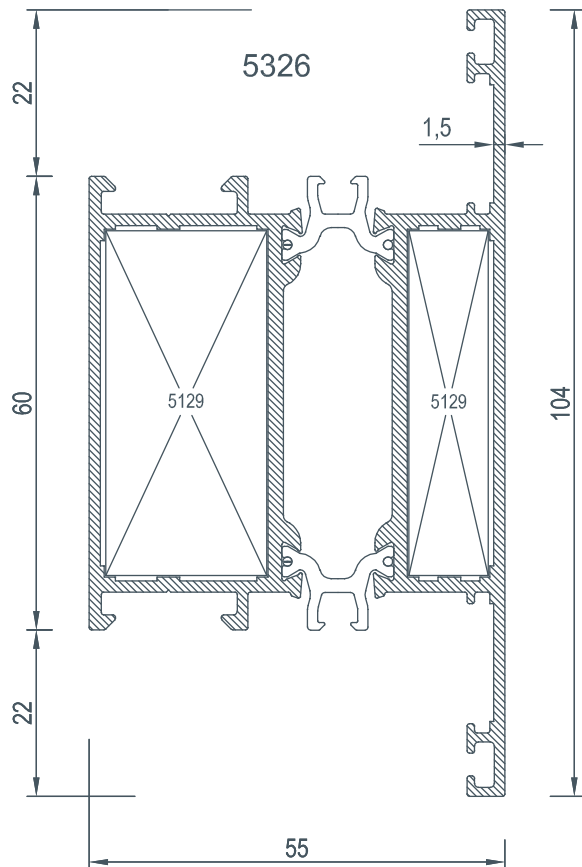

5327

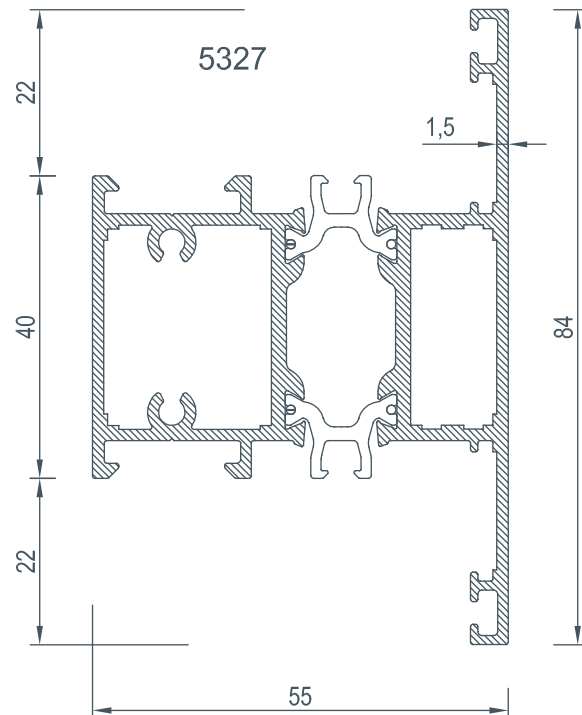

| COD<br>Code | AGIRLIK (kg/m)<br>Weight | Jxx cm <sup>4</sup> | Jyy cm <sup>4</sup> | L m |
|-------------|--------------------------|---------------------|---------------------|-----|
| 5328        | 2,188                    | 72,24               | 26,66               | 6   |
| 5329        | 2,381                    | 115,43              | 24,50               | 6   |

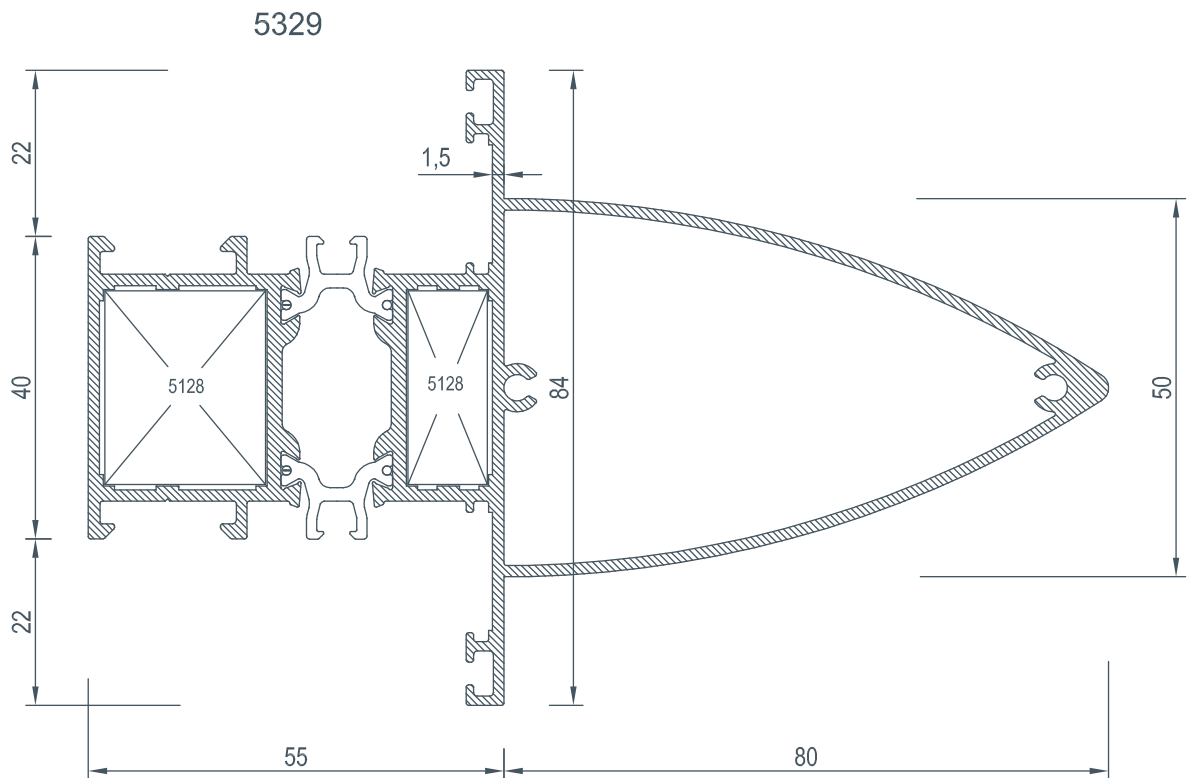
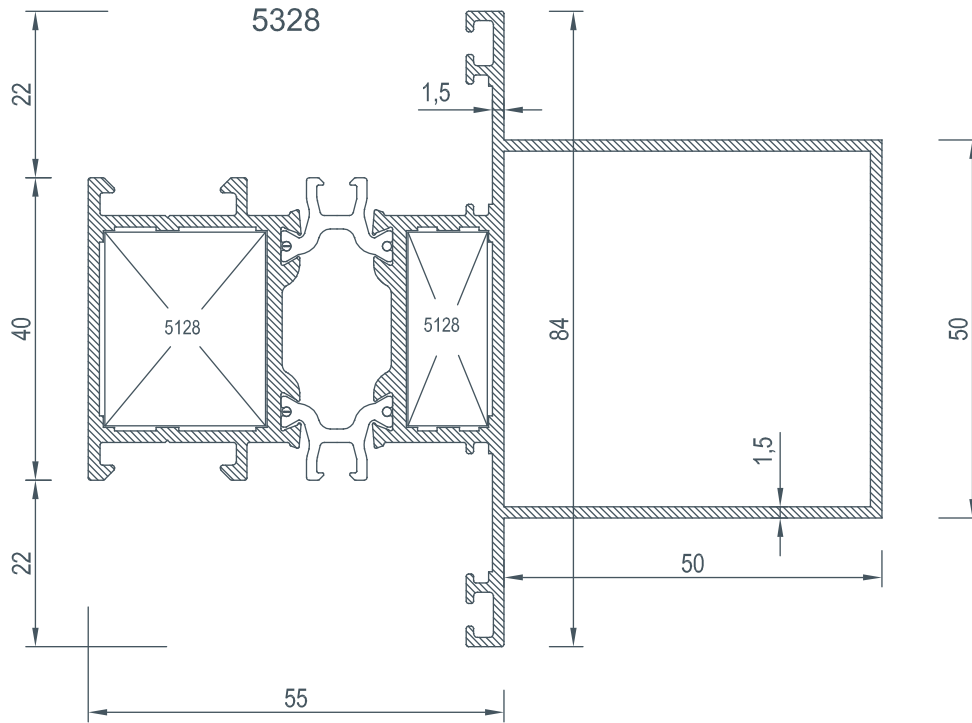

| COD<br>Code | AGIRLIK (kg/m)<br>Weight | Jxx cm <sup>4</sup> | Jyy cm <sup>4</sup> | L m |
|-------------|--------------------------|---------------------|---------------------|-----|
| 5330        | 2,314                    | 77,44               | 30,91               | 6   |

5330

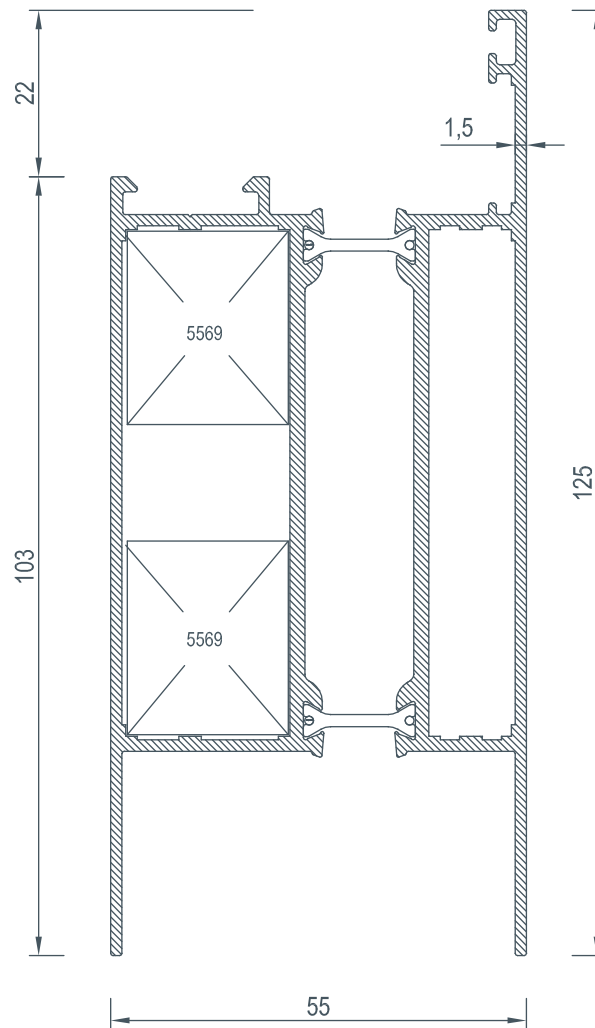

| COD<br>Code | AGIRLIK (kg/m)<br>Weight | Jxx cm4 | Jyy cm4 | L m |
|-------------|--------------------------|---------|---------|-----|
| 5331        | 1,300                    | 15,42   | 7,70    | 6   |
| 5332        | 1,379                    | 18,45   | 9,23    | 6   |
| 5335        | 1,142                    | 12,13   | 5,23    | 6   |

5331

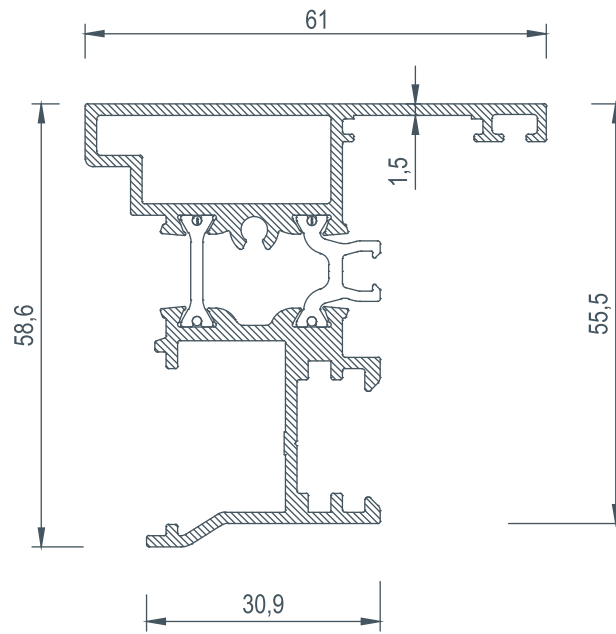

5332

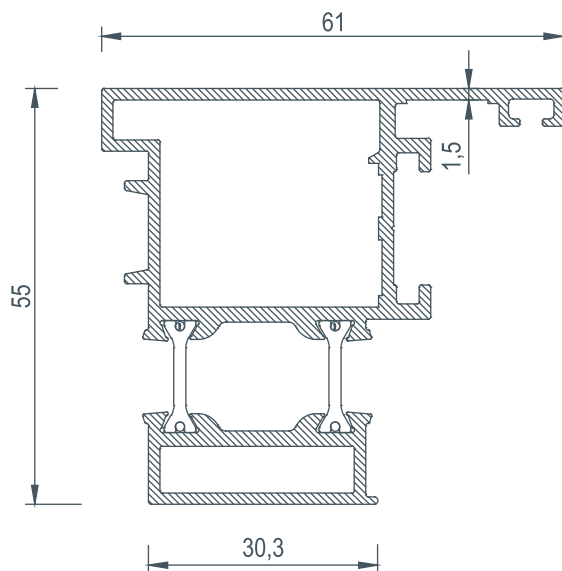

5335

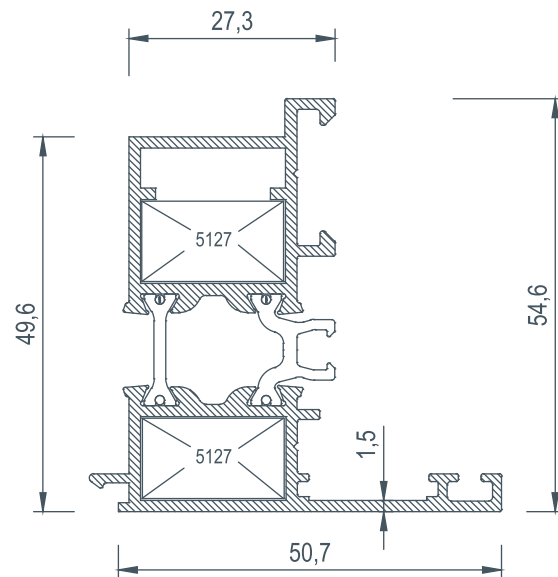





| COD<br>Code | AGIRLIK (kg/m)<br>Weight | Jxx cm <sup>4</sup> | Jyy cm <sup>4</sup> | L m |
|-------------|--------------------------|---------------------|---------------------|-----|
| 5316        | 1,987                    | 34,29               | 40,77               | 6   |
| 5117        | 0,105                    | ---                 | ---                 | 6   |
| 5336        | 1,098                    | 8,33                | 7,71                | 6   |
| 5337        | 0,151                    | ---                 | ---                 | 6   |
| 5338        | 0,258                    | ---                 | ---                 | 6   |
| 5339        | 0,374                    | ---                 | ---                 | 6   |

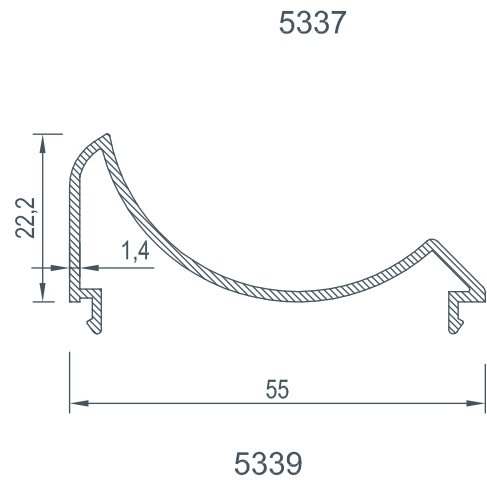
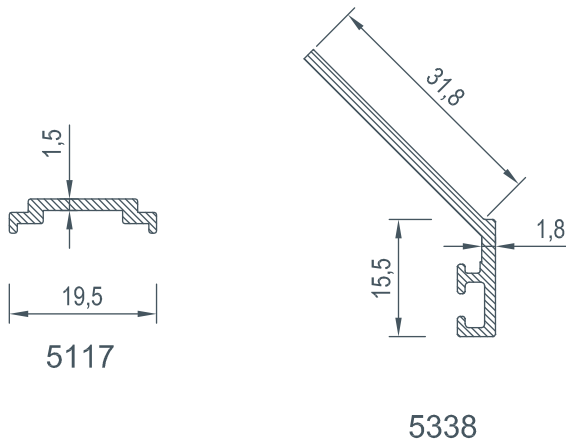
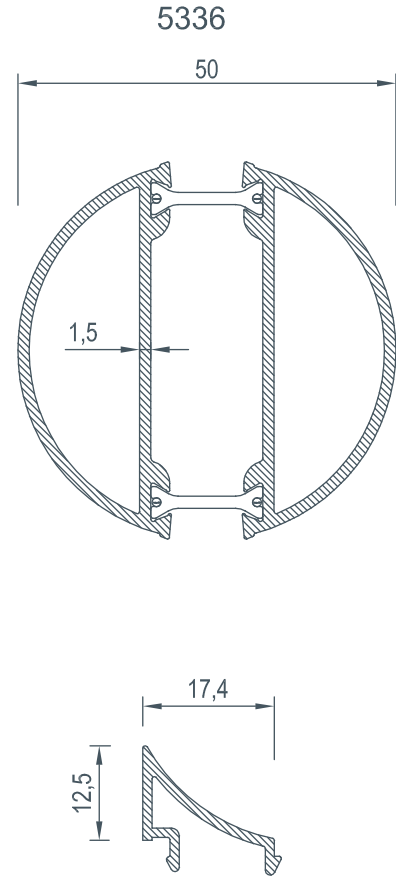
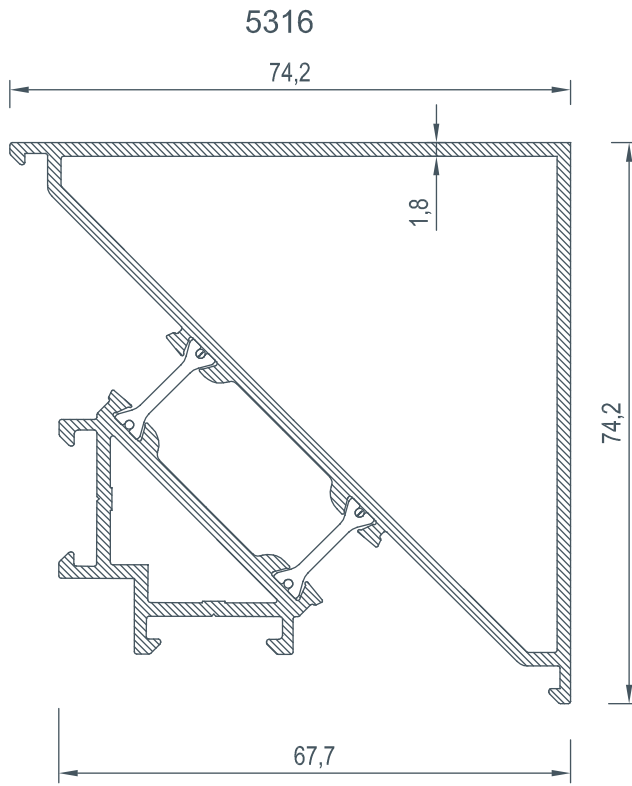



| COD<br>Code | AGIRLIK (kg/m)<br>Weight | Jxx cm4 | Jyy cm4 | L m |
|-------------|--------------------------|---------|---------|-----|
| 5127        | 3,484                    | ---     | ---     | 6   |

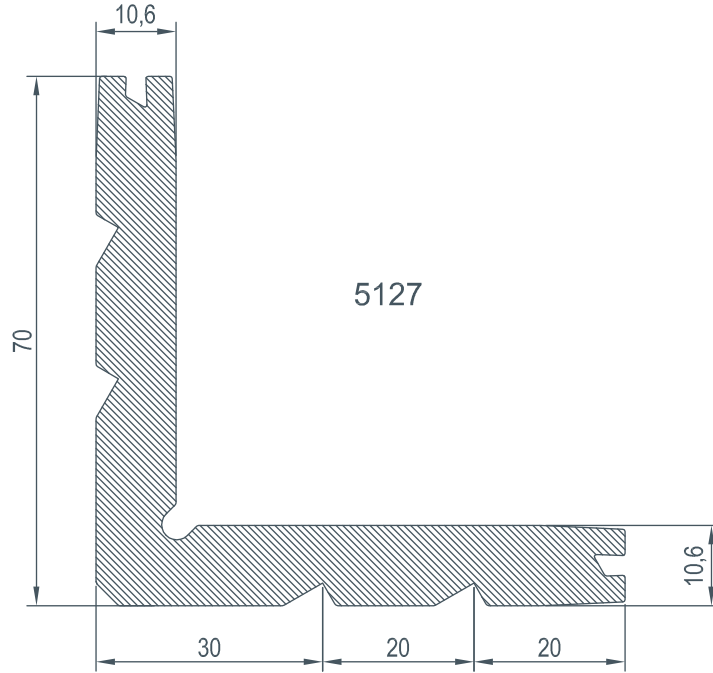

### KÖŞE TAKOZLARI / Corner Cleats

| Nr   | L m  | AKS. KODU<br>Acs. Code | KESİM ÖLÇÜSÜ<br>Cutting Size |
|------|------|------------------------|------------------------------|
| 5300 | 5127 | 5127-21,3              | 21,3 mm                      |
|      | 5127 | 5127-10,5              | 10,5 mm                      |
| 5303 | 5127 | 5127-18,6              | 18,6 mm                      |
|      | 5127 | 5127- 5,3              | 5,3 mm                       |
| 5307 | 5127 | 5127-21,3              | 21,3 mm                      |
|      | 5127 | 5127-10,5              | 10,5 mm                      |
| 5317 | 5127 | 5127-21,3              | 21,3 mm                      |
|      | 5127 | 5127-10,5              | 10,5 mm                      |
| 5320 | 5127 | 5127-18,6              | 18,6 mm                      |
|      | 5127 | 5127- 5,3              | 5,3 mm                       |
| 5324 | 5127 | 5127-21,3              | 21,3 mm                      |
|      | 5127 | 5127-10,5              | 10,5 mm                      |
| 5335 | 5127 | 5127-18,77             | 18,77 mm                     |
|      | 5127 | 5127-18,77             | 18,77 mm                     |



| COD<br>Code | AGIRLIK (kg/m)<br>Weight | Jxx cm4 | Jyy cm4 | L m |
|-------------|--------------------------|---------|---------|-----|
| 5128        | 3,652                    | ---     | ---     | 6   |

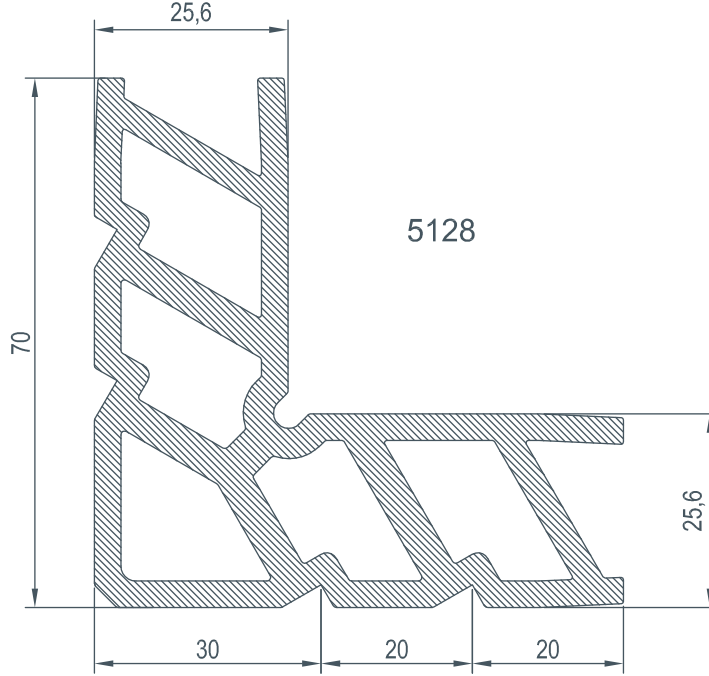

### KÖŞE TAKOZLARI / Corner Cleats

| Nr   |  L m | AKS. KODU<br>Acs. Code | KESİM ÖLÇÜSÜ<br>Cutting Size |
|------|---|------------------------|------------------------------|
| 5301 | 5128  | 5128-21,3              | 21,3 mm                      |
|      | 5128  | 5128-10,5              | 10,5 mm                      |
| 5304 | 5128  | 5128-18,6              | 18,6 mm                      |
|      | 5128  | 5128-5,3               | 5,3 mm                       |
| 5308 | 5128  | 5128-21,3              | 21,3 mm                      |
|      | 5128  | 5128-10,5              | 10,5 mm                      |
| 5311 | 5128  | 5128-21,3              | 21,3 mm                      |
|      | 5128  | 5128-10,5              | 10,5 mm                      |
| 5312 | 5128  | 5128-21,3              | 21,3 mm                      |
|      | 5128  | 5128-10,5              | 10,5 mm                      |
| 5318 | 5128  | 5128-21,3              | 21,3 mm                      |
|      | 5128  | 5128-10,5              | 10,5 mm                      |
| 5321 | 5128  | 5128-18,6              | 18,6 mm                      |
|      | 5128  | 5128-5,3               | 5,3 mm                       |
| 5325 | 5128  | 5128-21,3              | 21,3 mm                      |
|      | 5128  | 5128-10,5              | 10,5 mm                      |
| 5328 | 5128  | 5128-21,3              | 21,3 mm                      |
|      | 5128  | 5128-10,5              | 10,5 mm                      |
| 5329 | 5128  | 5128-21,3              | 21,3 mm                      |
|      | 5128  | 5128-10,5              | 10,5 mm                      |
| 5333 | 5128  | 5128-18,3              | 18,3 mm                      |
|      | 5128  | 5128-5,4               | 5,4 mm                       |



| COD<br>Code | AGIRLIK (kg/m)<br>Weight | Jxx cm4 | Jyy cm4 | L m |
|-------------|--------------------------|---------|---------|-----|
| 5129        | 4,618                    | ---     | ---     | 6   |

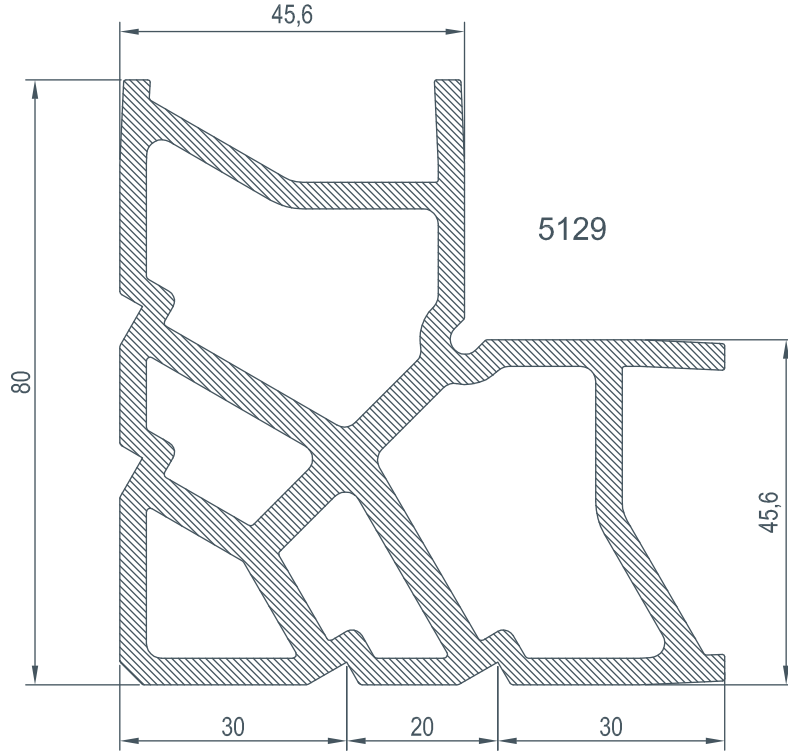



### KÖŞE TAKOZLARI / Corner Cleats

| Nr   |  L m | AKS. KODU<br>Acs. Code | KESİM ÖLÇÜSÜ<br>Cutting Size |
|------|---|------------------------|------------------------------|
| 5302 | 5129  | 5129-21,3              | 21,3 mm                      |
|      | 5129  | 5129-10,5              | 10,5 mm                      |
| 5306 | 5129  | 5129-26,7              | 26,7 mm                      |
|      | 5129  | 5129-5,3               | 5,3 mm                       |
| 5309 | 5129  | 5129-21,3              | 21,3 mm                      |
|      | 5129  | 5129-10,5              | 10,5 mm                      |
| 5319 | 5129  | 5129-21,3              | 21,3 mm                      |
|      | 5129  | 5129-10,5              | 10,5 mm                      |
| 5323 | 5129  | 5129-26,7              | 26,7 mm                      |
|      | 5129  | 5129-5,3               | 5,3 mm                       |
| 5326 | 5129  | 5129-21,3              | 21,3 mm                      |
|      | 5129  | 5129-10,5              | 10,5 mm                      |
| 5334 | 5129  | 5129-18,3              | 18,3 mm                      |
|      | 5129  | 5129-5,4               | 5,4 mm                       |

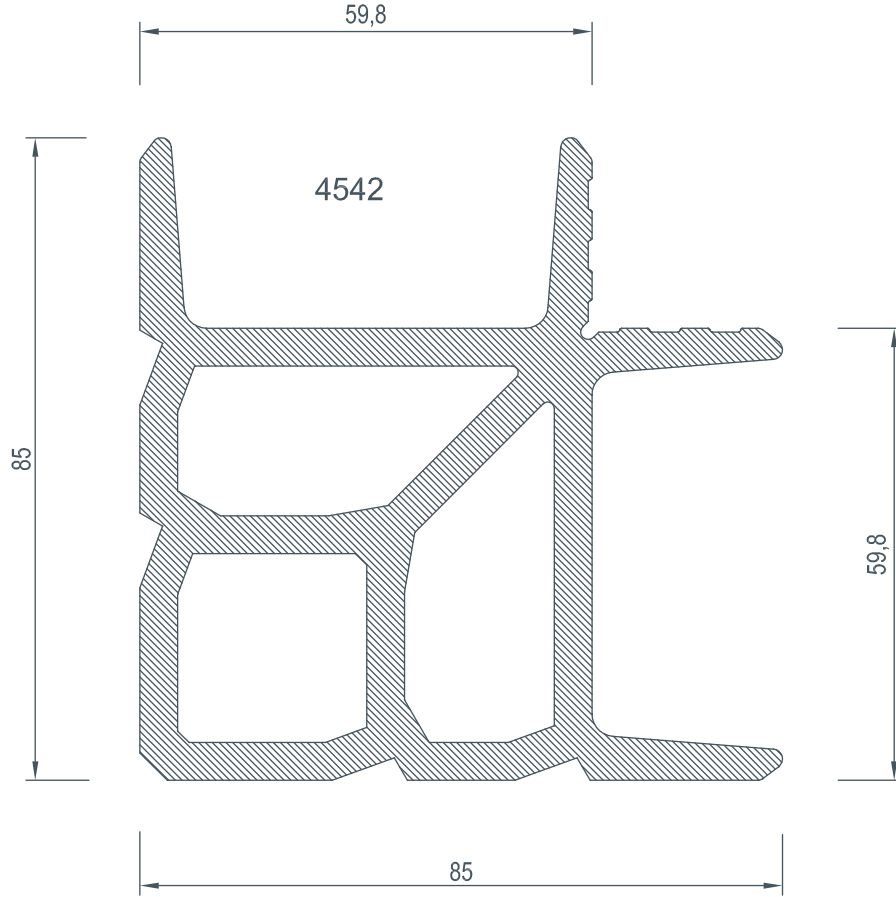

| COD<br>Code | AGIRLIK (kg/m)<br>Weight | Jxx cm4 | Jyy cm4 | L m |
|-------------|--------------------------|---------|---------|-----|
| 4542        | 5,381                    | ---     | ---     | 6   |

**KÖŞE TAKOZLARI / Corner Cleats**

| Nr   |  | AKS. KODU<br>Acs. Code | KESİM ÖLÇÜSÜ<br>Cutting Size |
|------|---|------------------------|------------------------------|
| 5564 | 4542  | 4542-18,6              | 18,6 mm                      |
|      | 4542  | 4542- 5,3              | 5,3 mm                       |
| 5567 | 4542  | 4542-18,6              | 18,6 mm                      |
|      | 4542  | 4542- 5,3              | 5,3 mm                       |



| COD<br>Code | AGIRLIK (kg/m)<br>Weight | Jxx cm <sup>4</sup> | Jyy cm <sup>4</sup> | L m |
|-------------|--------------------------|---------------------|---------------------|-----|
| 5569        | 0,555                    | ---                 | ---                 | 6   |
| 5570        | 0,393                    | ---                 | ---                 | 6   |
| 5571        | 0,772                    | ---                 | ---                 | 6   |

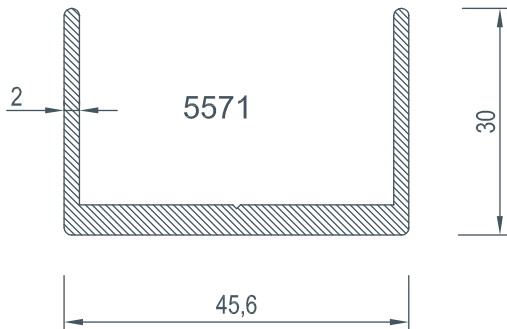
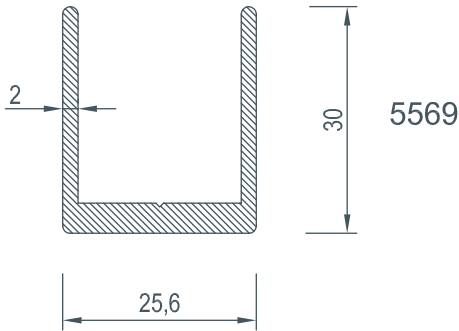
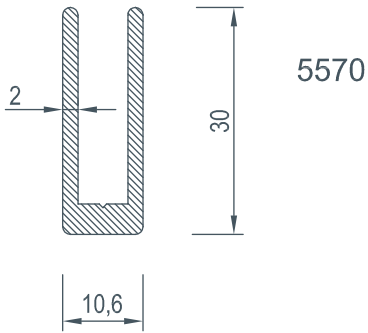

**ORTA KAYIT BAĞLANTI / Mullion Connection Piece**

| Nr   |  L m |  AKS. KODU<br>Ac. Code | KESİM ÖLÇÜSÜ<br>Cutting Size |
|------|--|--|------------------------------|
| 5307 | 5570   | 5570-21,3  | 21,3 mm                      |
| 5308 | 5569   | 5569-21,3  | 21,3 mm                      |
| 5309 | 5571   | 5571-21,3  | 21,3 mm                      |
| 5310 | ---  | ---  | ---                          |
| 5311 | 5569   | 5569-45,6  | 21,3 mm                      |
| 5312 | 5569   | 5569-45,6  | 21,3 mm                      |
| 5313 | 5569   | 5569-45,6  | 21,3 mm                      |
| 5324 | 5570   | 5570-21,3  | 21,3 mm                      |
| 5325 | 5569   | 5569-21,3  | 21,3 mm                      |
| 5326 | 5571   | 5571-21,3  | 21,3 mm                      |
| 5327 | ---  | ---  | ---                          |
| 5328 | 5569   | 5569-45,6  | 21,3 mm                      |
| 5329 | 5569   | 5569-45,6  | 21,3 mm                      |
| 5330 | 5569   | 5569-45,6  | 21,3 mm                      |



**E 55**

**E1 - E2**

---

# **DETAYLAR**

## *DETAILS*

---





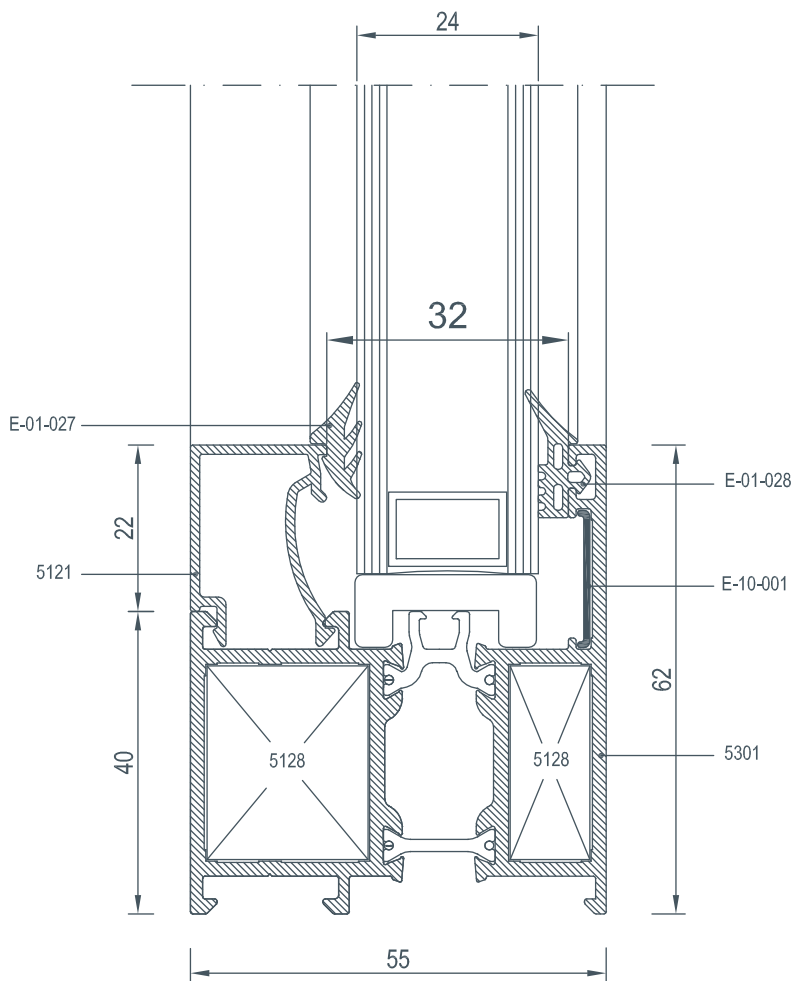
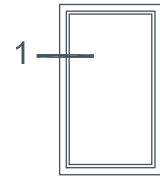
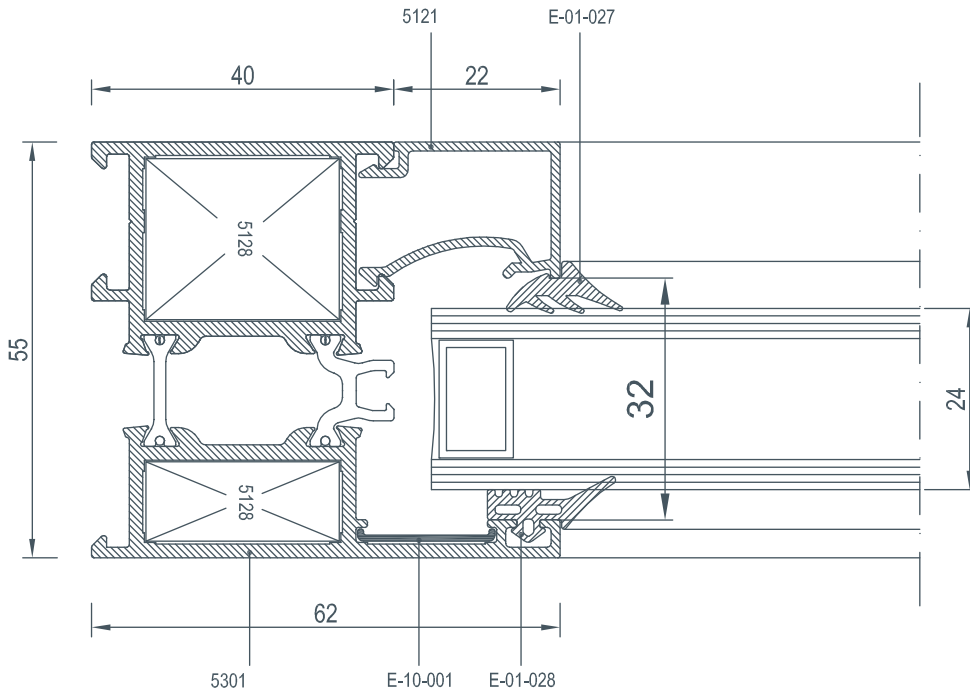

**E1 - E2**

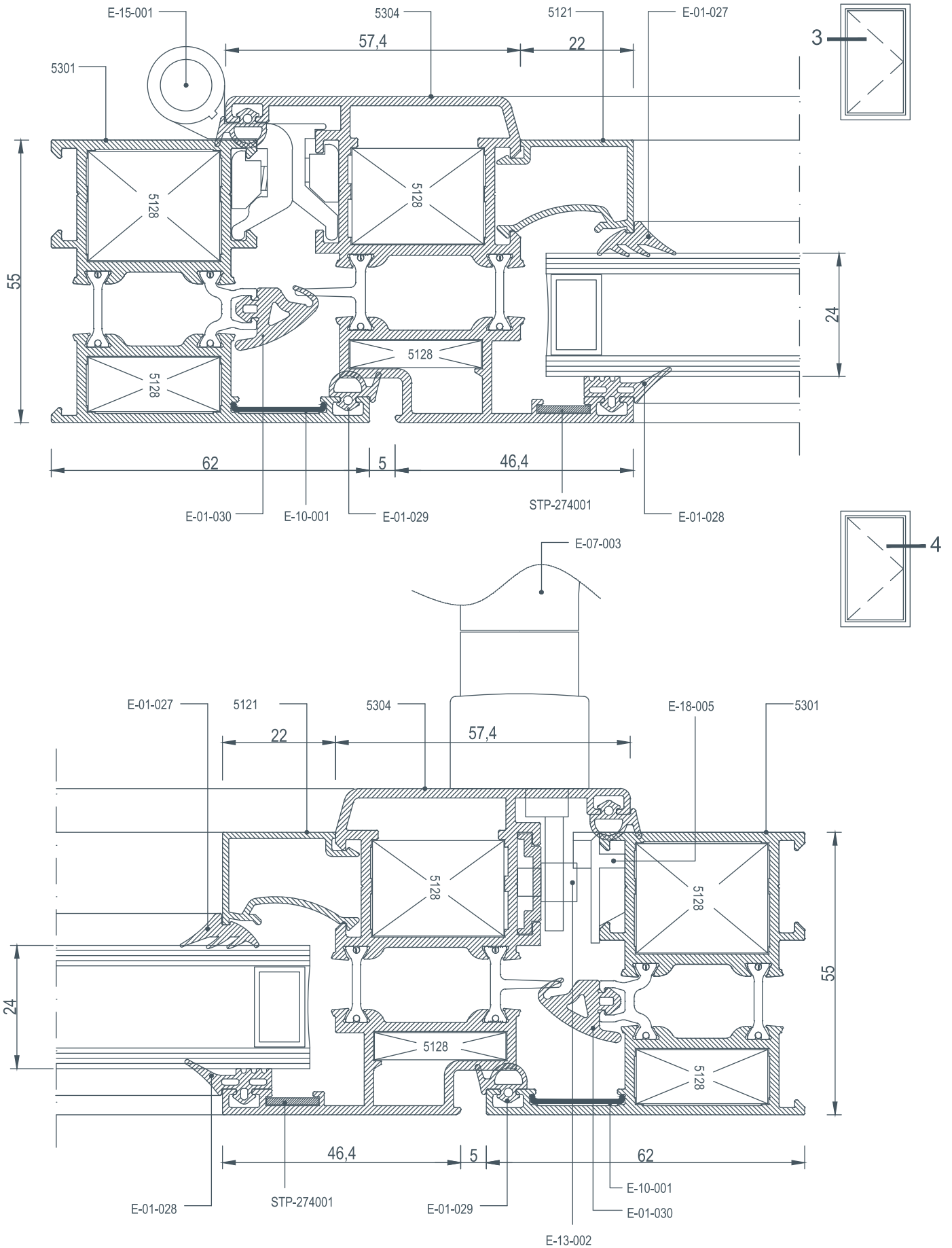

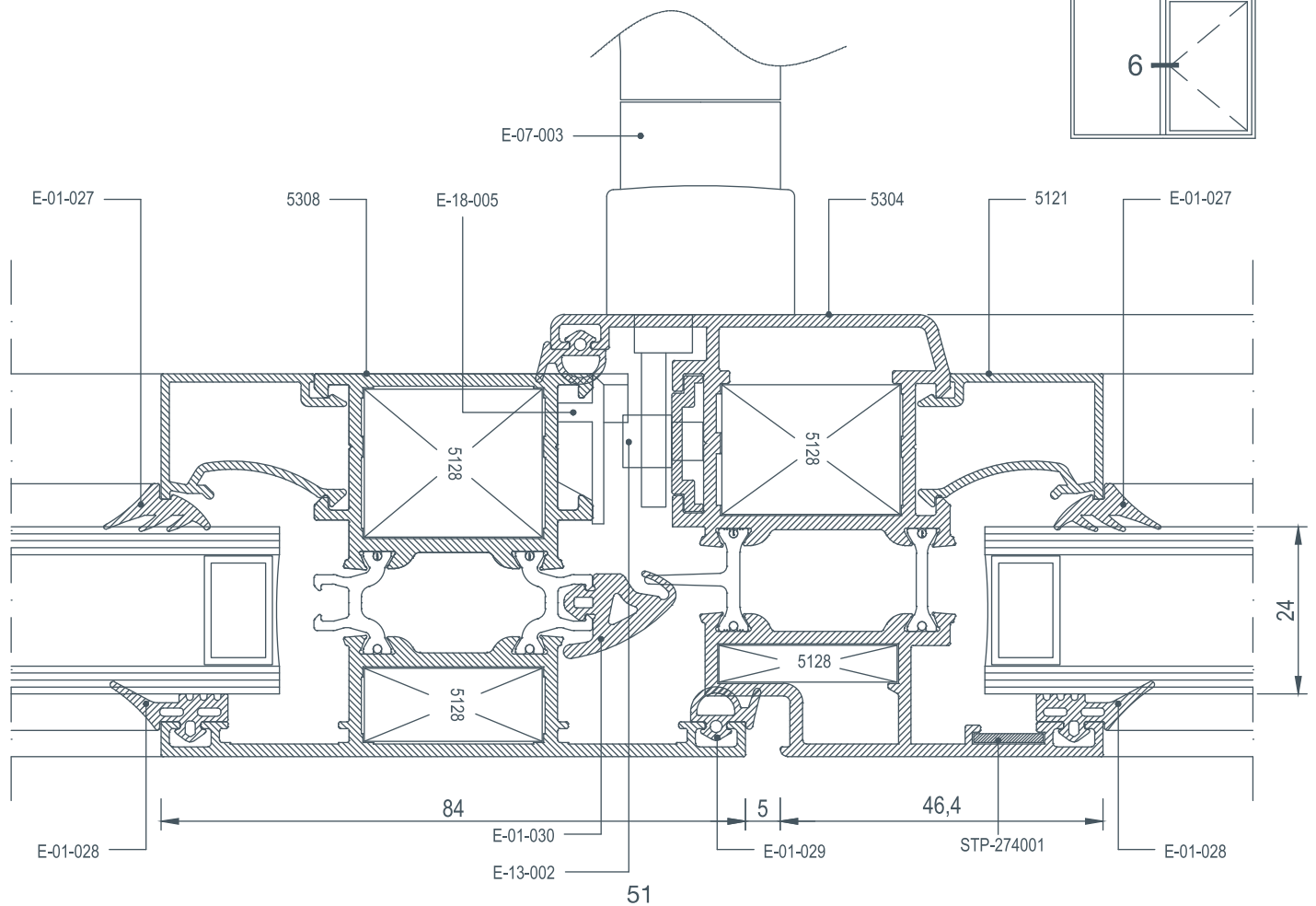
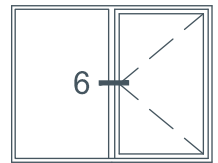
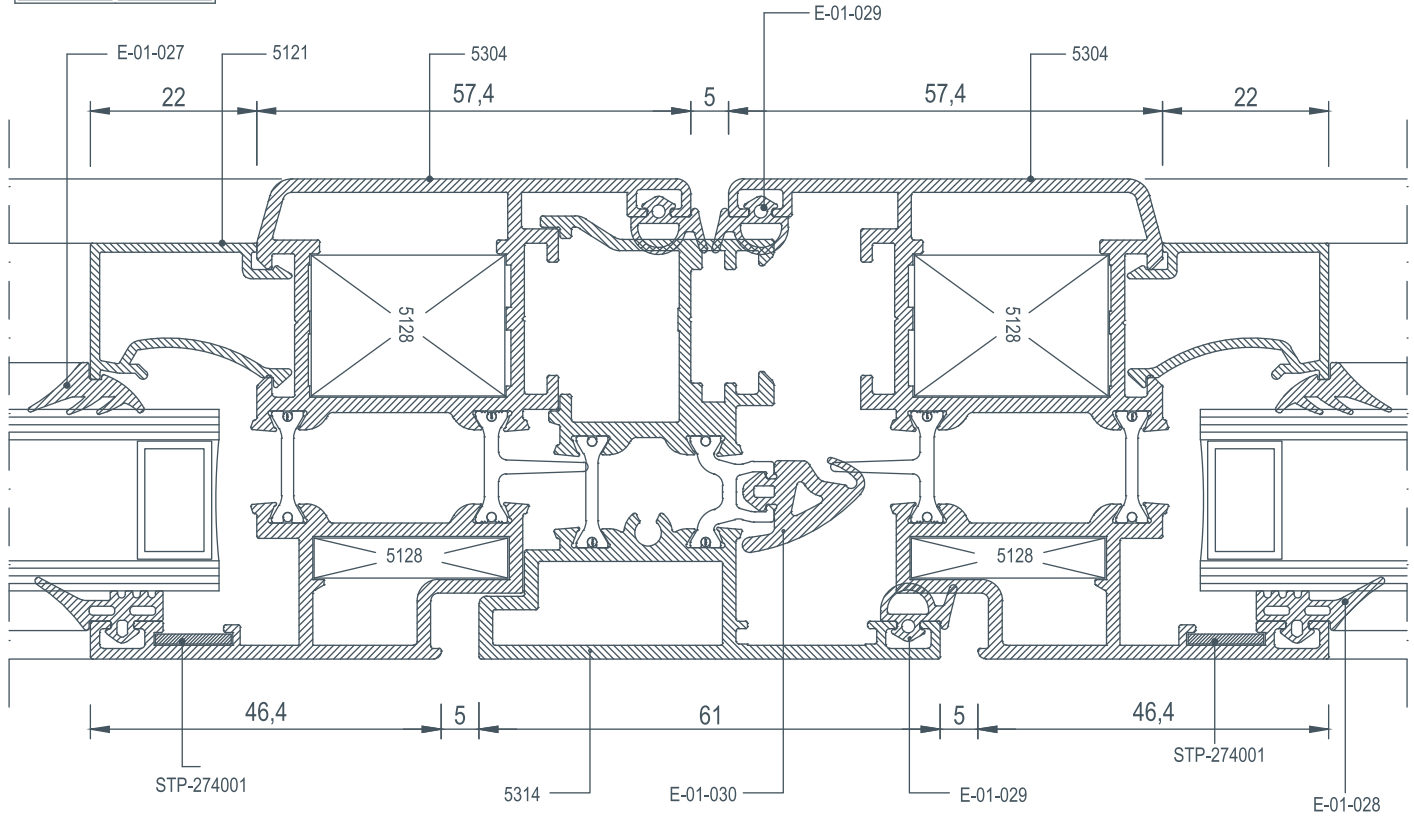
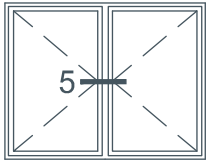

**E1 - E2**

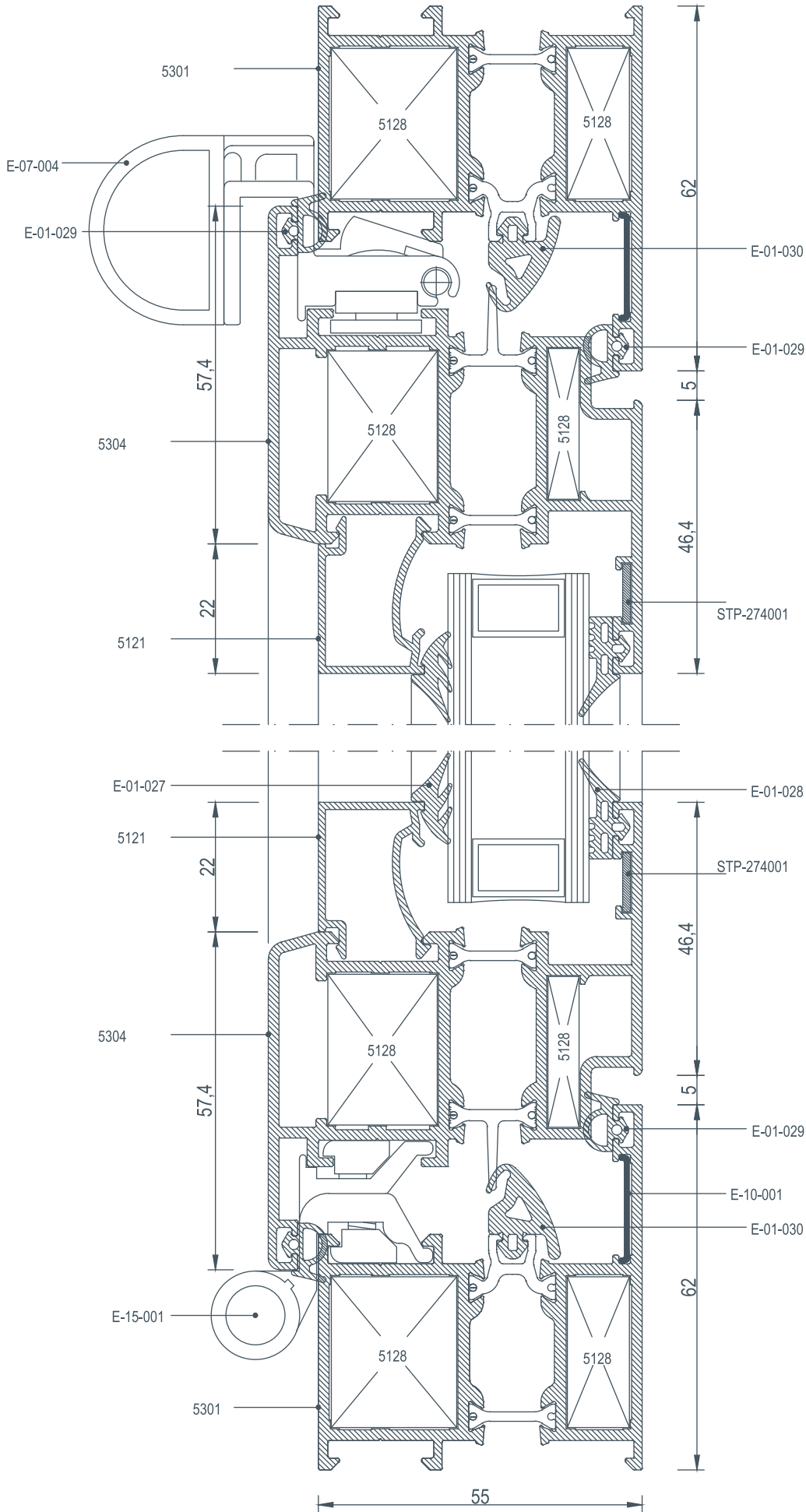

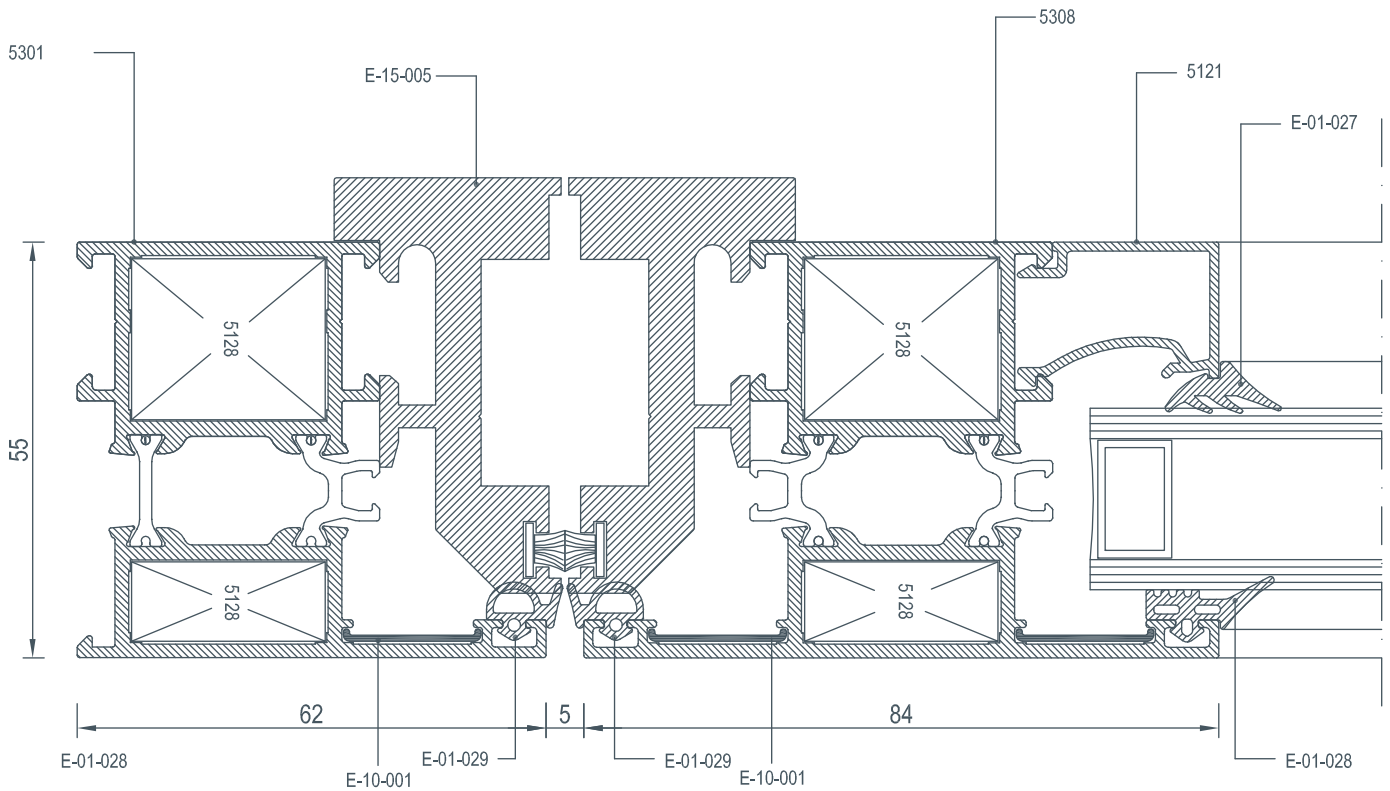
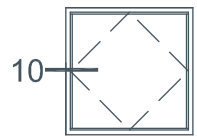
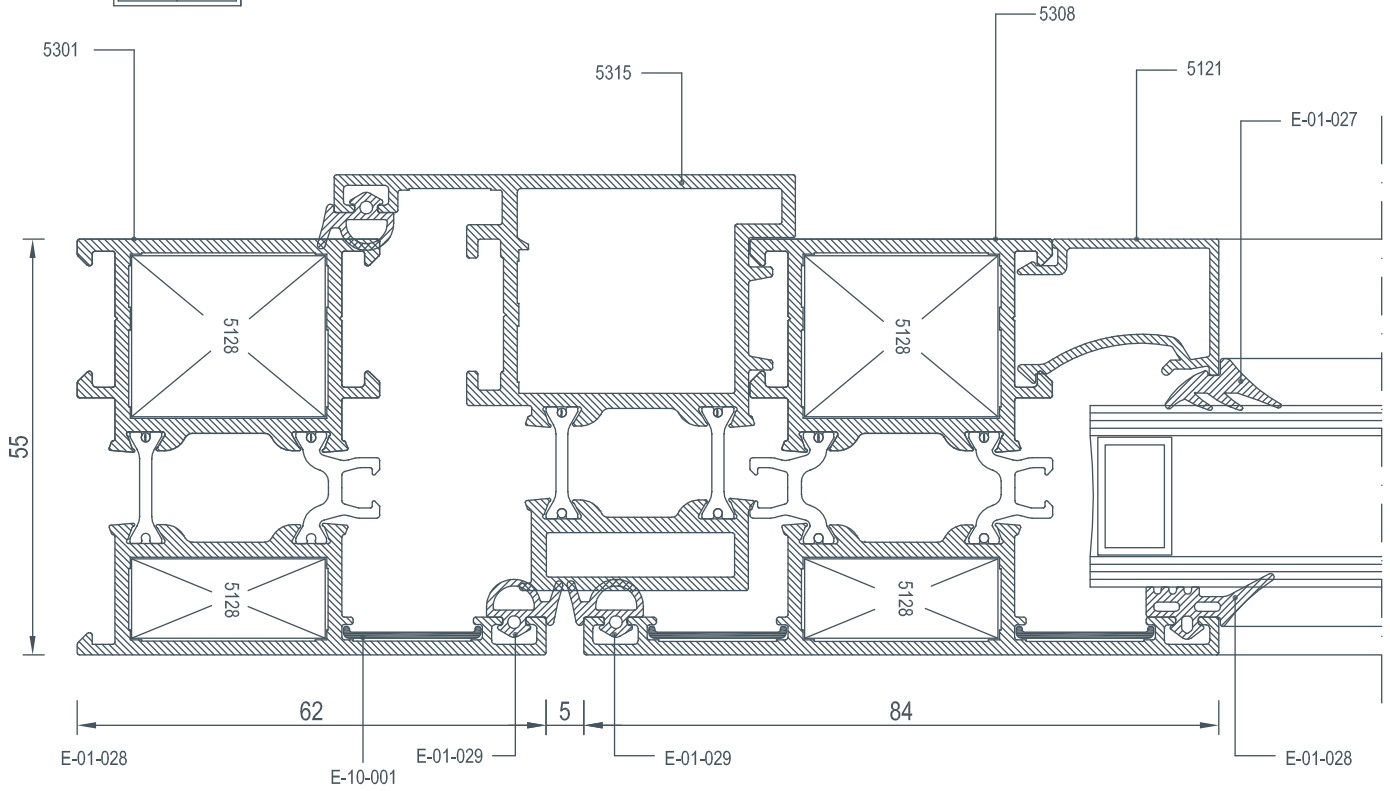
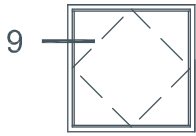



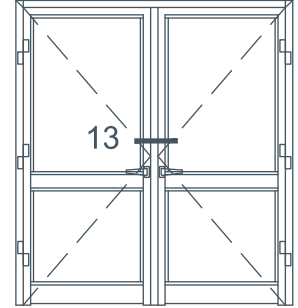
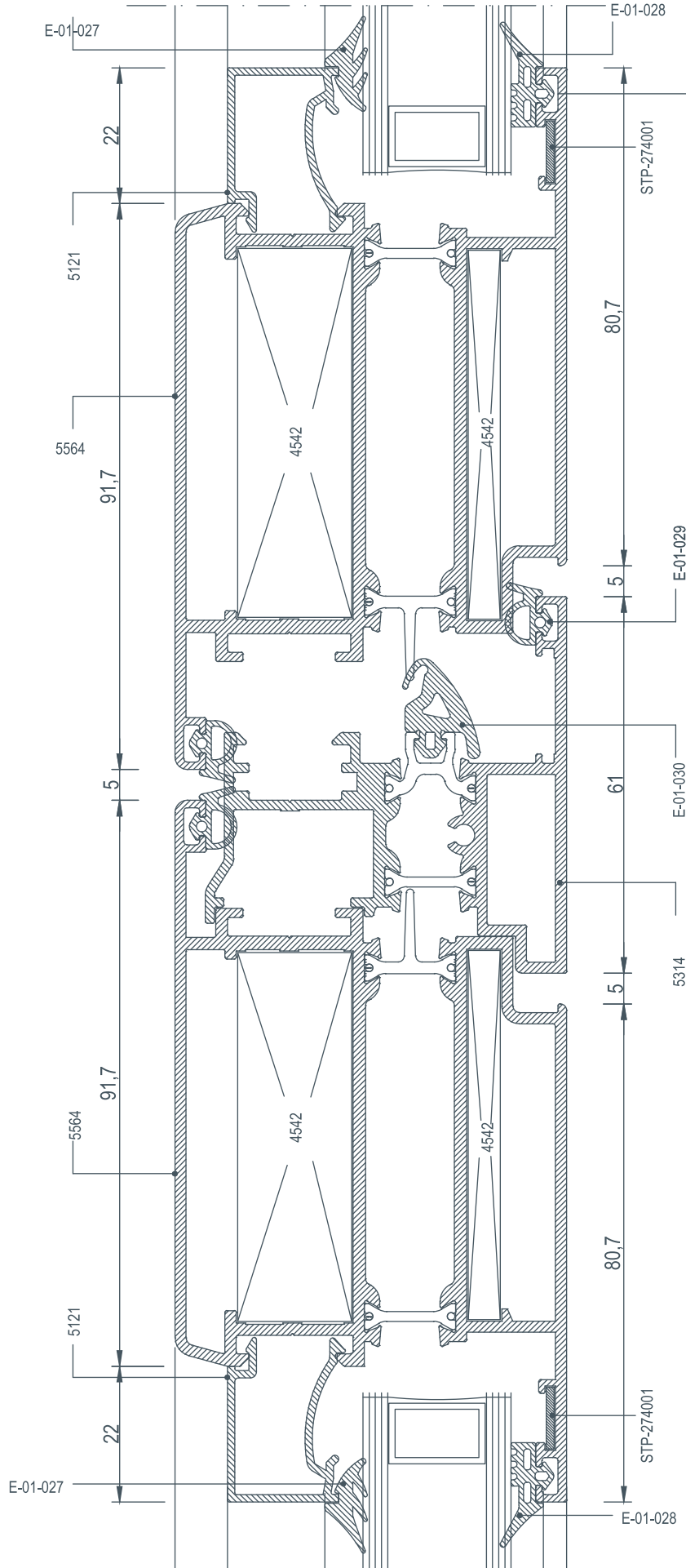

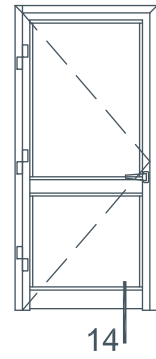
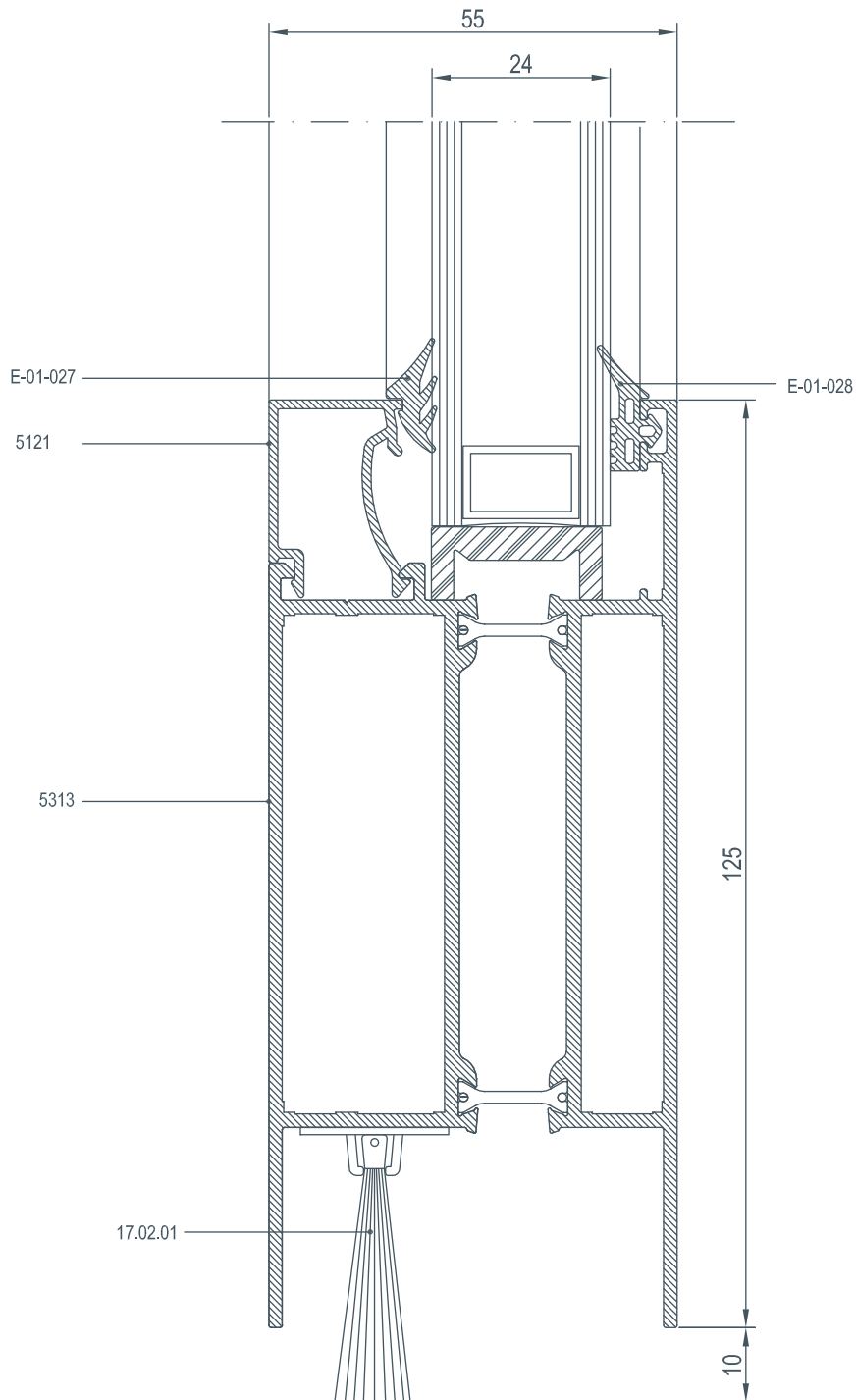



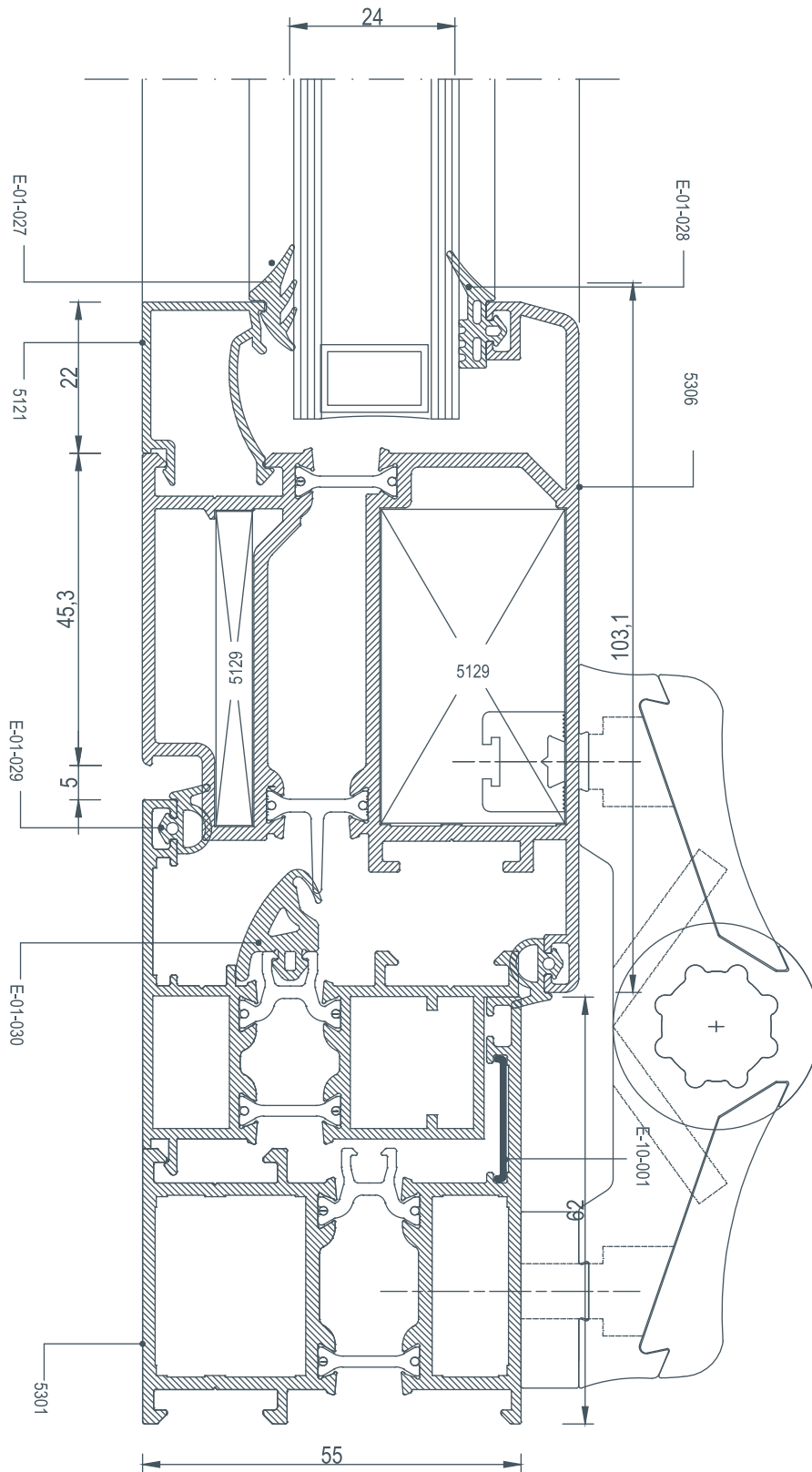
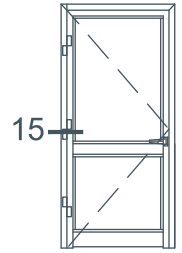

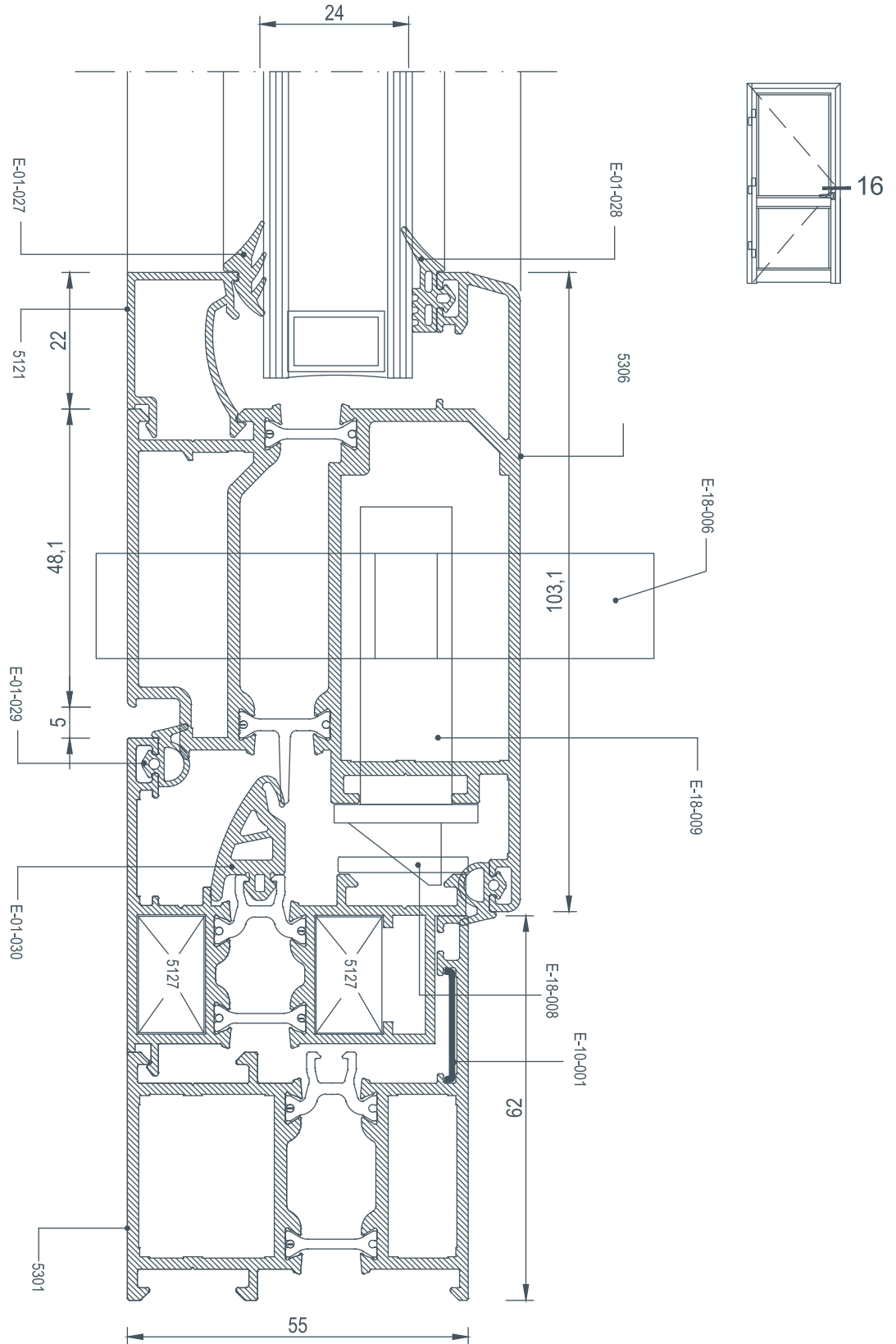

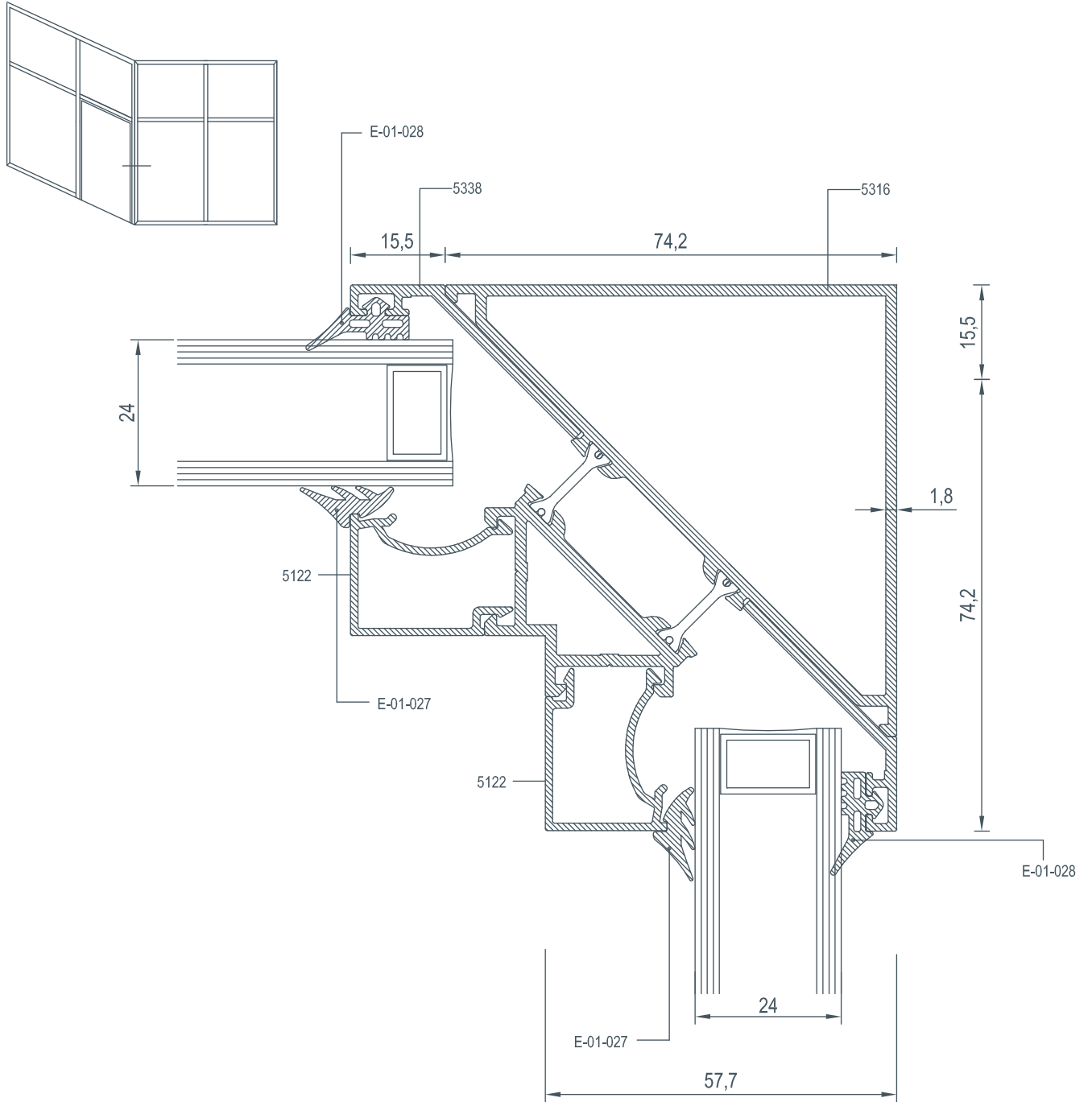

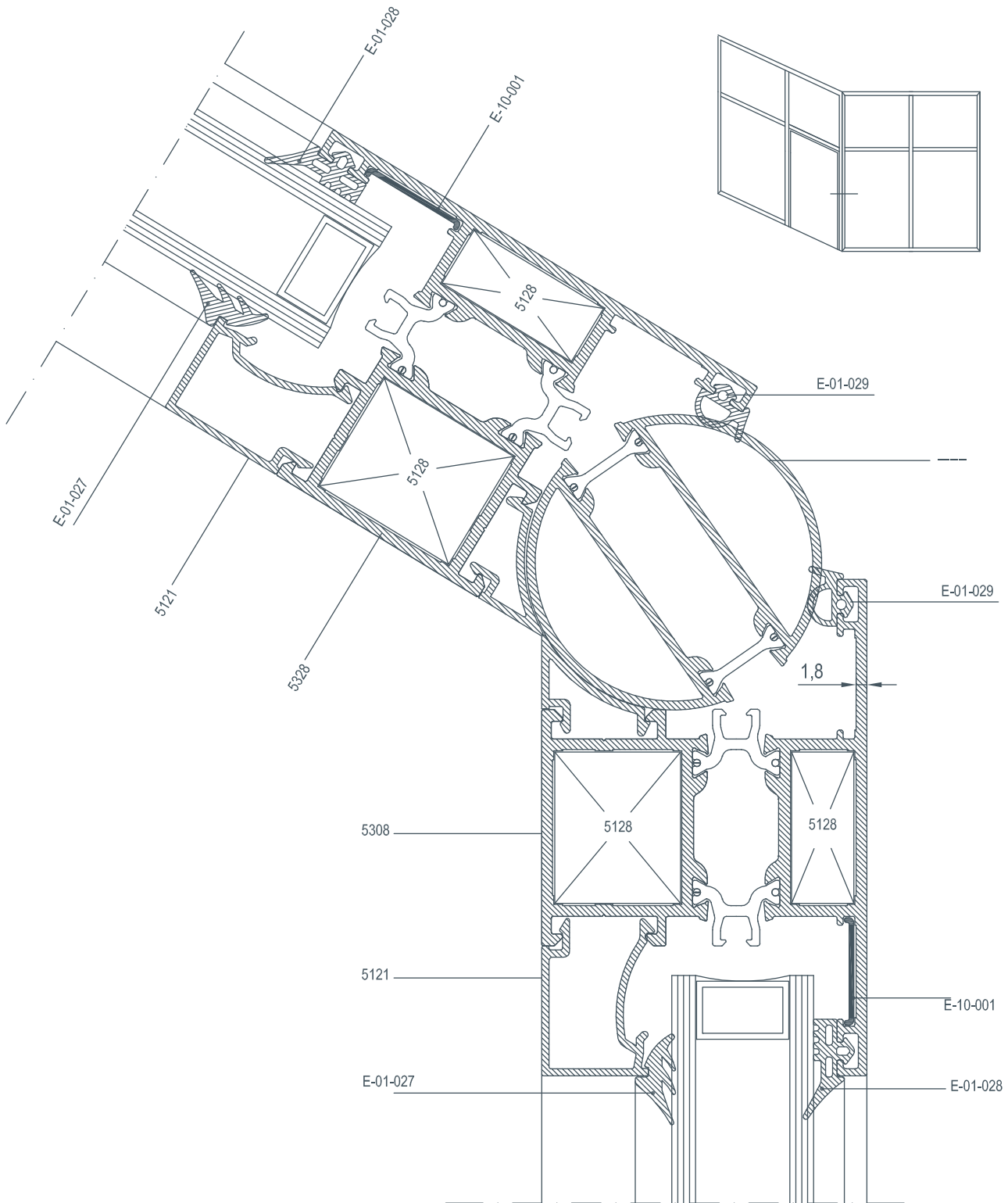

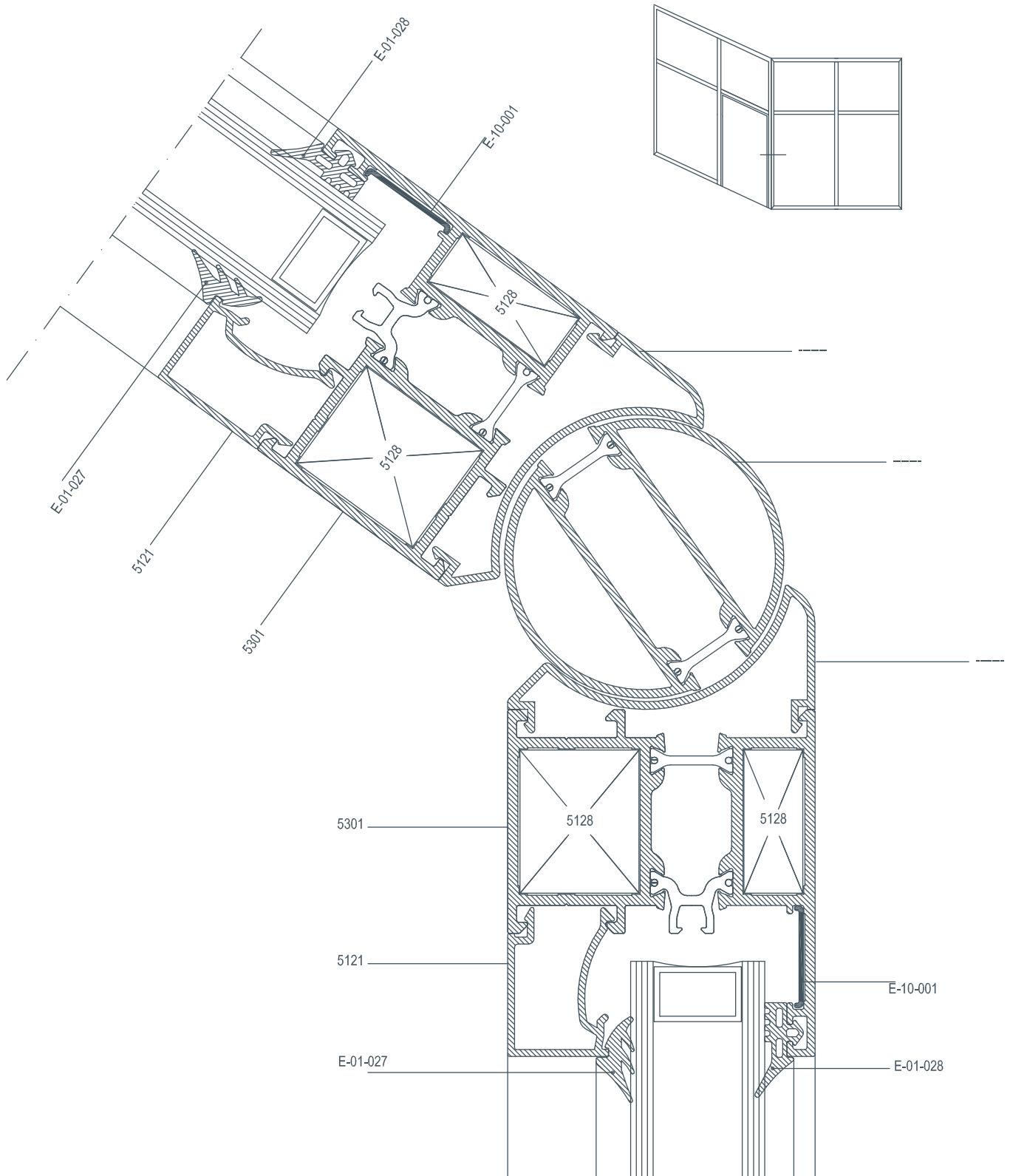





E 55

E1 - E2

---









# AKSESUARLAR

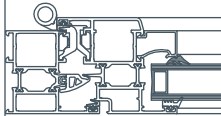
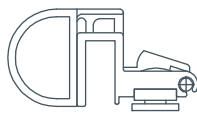
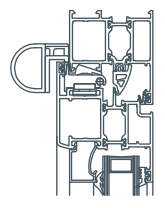

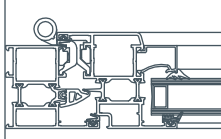
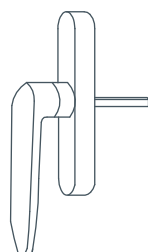
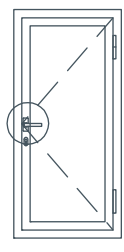

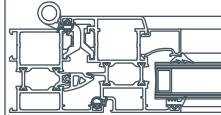
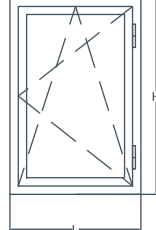
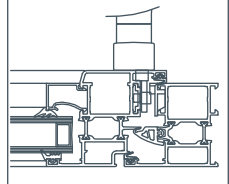
## *ACCESSORIES*

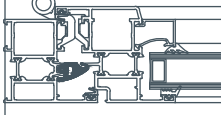
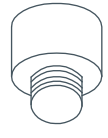
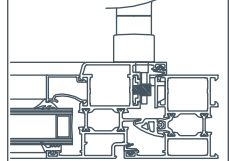
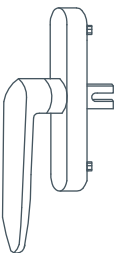
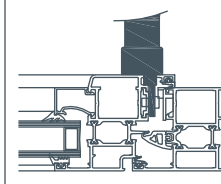

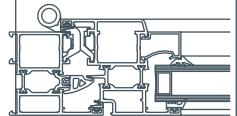
---

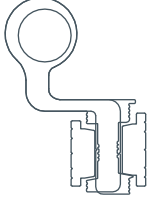
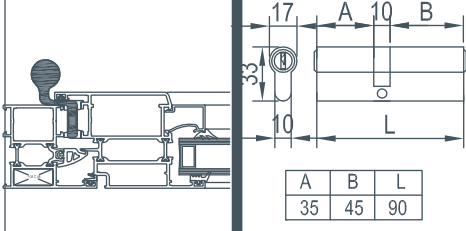
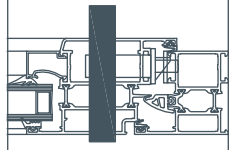
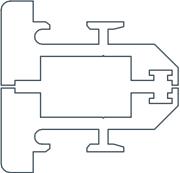
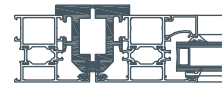
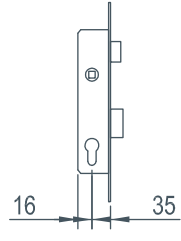
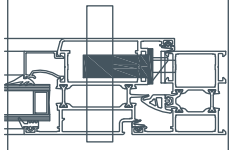
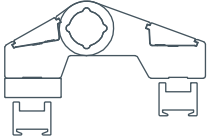
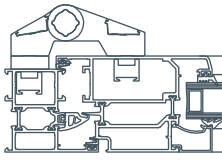

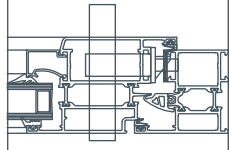
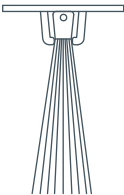
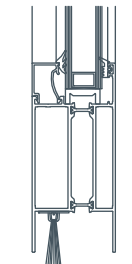
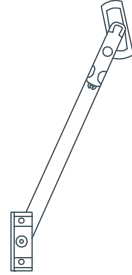
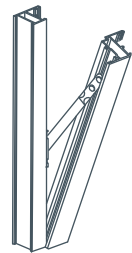

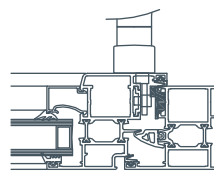
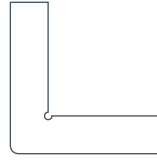
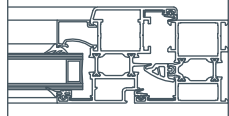
|   |   |   |  |  |   |
|---|---|---|--|--|---|
|    | <p><b>E-01-027</b></p> <p>iç cam fitili<br/>Inside gasket</p> <p>54 gr/mt</p>       |    |    | <p><b>E-07-004</b></p> <p>Vasistas Mandal<br/>Vasistas Spring</p>  |    |
|    | <p><b>E-01-028</b></p> <p>Dış cam fitili<br/>outside gasket</p> <p>60 gr/mt</p>     |    |   | <p><b>E-07-005</b></p> <p>Kapı Kolu<br/>Door Handle</p>  |   |
|  | <p><b>E-01-029</b></p> <p>Dış Bini Fitili<br/>Acoustical Gasket</p> <p>40 gr/mt</p> |  |  | <p><b>E-07-006</b></p> <p>Çift Açılım Mekanizması<br/>Tilt and Turn Mechanism</p> <p>L: 570~1000 mm<br/>H: 400~1200 mm</p> |  |
|  | <p><b>E-01-030</b></p> <p>Tozluk Fitili<br/>Central gasket</p> <p>120 gr/mt</p>     |  |   | <p><b>E-13-002</b></p> <p>Tij Pimi<br/>Lock Pin</p>  |  |
|  | <p><b>E-07-003</b></p> <p>İspanyolet Kol<br/>Window handle</p>                      |  |  | <p><b>E-15-001</b></p> <p>Pencere Menteşesi<br/>Window Hinge</p>   |  |

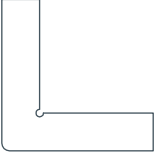
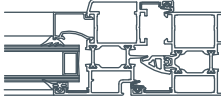
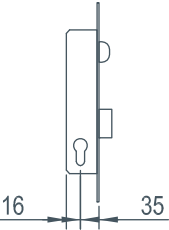
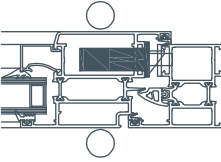
|    | <b>E-15-004</b><br>Kapı Menteşesi<br>Door Hinge       |   | <table border="1" data-bbox="860 654 998 723"> <thead> <tr> <th>A</th> <th>B</th> <th>L</th> </tr> </thead> <tbody> <tr> <td>35</td> <td>45</td> <td>90</td> </tr> </tbody> </table> | A   | B   | L | 35 | 45 | 90 | <b>E-18-006</b><br>Barel<br>Cylinder |  |
|---|---|---|--|---|---|---|----|----|----|--------------------------------------|---|
| A   | B   | L   |  |   |   |   |    |    |    |                                      |   |
| 35  | 45  | 90  |  |   |   |   |    |    |    |                                      |   |
|   | <b>E-15-005</b><br>Pivot Menteşe<br>Pivot Hinge       |    |   | <b>E-18-009</b><br>Dilli Kilit<br>Mortise Lock          |   |   |    |    |    |                                      |   |
|  | <b>E-15-006</b><br>Kapı Menteşesi<br>Door Hinge       |  |   | <b>E-18-008</b><br>Dilli Kilit Karşılığı<br>Forend      |  |   |    |    |    |                                      |   |
|  | <b>E-17-003</b><br>Kapı Altı Fırçası<br>Brush<br>1 Mt |  |   | <b>E-23-002</b><br>Vasistas Makas<br>Vasistas Accessory |  |   |    |    |    |                                      |   |
|  | <b>E-18-005</b><br>Ayarlı Pim Karşılığı<br>Lock Plate |  |    | <b>E-10-001</b><br>Köşe Çavuşu<br>Corner joint          |  |   |    |    |    |                                      |   |

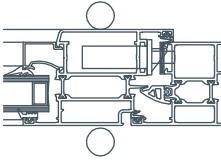
|   |  |   |  |  |  |
|---|--|---|--|--|--|
|    | <p><b>STP-274001</b><br/>Köşe Çavuşu<br/>Corner joint</p>                    |    |  |  |  |
|   | <p><b>E-18-009-1</b><br/>Makaralı Kilit<br/>Roller Lock</p>                  |   |  |  |  |
|  | <p><b>E-18-008-1</b><br/>Makaralı kilit Karşılığı<br/>Roller Lock Forend</p> |  |  |  |  |
|   |  |   |  |  |  |
|   |  |   |  |  |  |

