



E4

E 74 - 1.8T - E4
YALITIMLI PENCERE VE KAPI SİSTEMLERİ









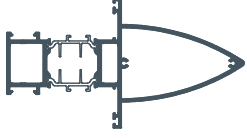

E 74 - 1.8T - E4
INSULATED WINDOWS & DOORS SYSTEMS

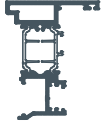
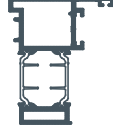

E 74



COD Code	PROFİL KESİTİ Profile View	PROFİL AÇIKLAMASI Profile Description	AGIRLIK (kg/m) Weight	Jxx cm ⁴	Jyy cm ⁴
5500		KASA PROFİLİ	1,311	32,04	3,74
5501		KASA PROFİLİ	1,651	41,19	10,54
5502		KASA PROFİLİ	2,063	54,33	28,10
5503		KANAT PROFİLİ	1,607	48,33	4,25
5504		KANAT PROFİLİ	1,945	61,76	12,93
5568		İÇE AÇILIR KAPI KANAT PRF.	2,659	97,83	52,43
5506		DIŞA AÇILIR KAPI KANAT PRF.	2,469	72,96	48,31
5507		ORTA KAYIT PROFİLİ	1,468	35,71	7,96
5508		ORTA KAYIT PROFİLİ	1,808	45,21	17,37
5509		ORTA KAYIT PROFİLİ	2,220	57,40	39,90
5510		ORTA KAYIT PROFİLİ	1,881	47,93	17,70

COD Code	PROFİL KESİTİ Profile View	PROFİL AÇIKLAMASI Profile Description	AGIRLIK (kg/m) Weight	Jxx cm ⁴	Jyy cm ⁴
5512		TAKV.ORTA KAYIT PROFİLİ	2,724	177,13	26,77
5513		ETEK PROFİLİ	2,660	89,43	69,49
5514		ÇİFT KANAT ADAPTÖR PROF.	1,540	35,15	8,37
5515		PİVOT ADAPTÖR PROFİLİ	1,642	27,52	10,66
5516		KÖŞE DÖNÜŞ PROFİLİ	2,141	61,27	40,77
5117		TİJ PROFİLİ	0,105	---	---
5572		TİJ PROFİLİ (BOYALI PROFİLLER İÇİN)	0,100	---	---
5118		CAM ÇİTASI PROFİLİ	0,249	---	---
5119		CAM ÇİTASI PROFİLİ	0,251	---	---
5120		CAM ÇİTASI PROFİLİ	0,254	---	---
5121		CAM ÇİTASI PROFİLİ	0,259	---	---



COD Code	PROFİL KESİTİ Profile View	PROFİL AÇIKLAMASI Profile Description	AGIRLIK (kg/m) Weight	Jxx cm ⁴	Jyy cm ⁴
5122		CAM ÇİTASI PROFİLİ	0,267	---	---
5123		CAM ÇİTASI PROFİLİ	0,274	---	---
5124		CAM ÇİTASI PROFİLİ	0,281	---	---
5125		CAM ÇİTASI PROFİLİ	0,292	---	---
5526		CAM ÇİTASI PROFİLİ	0,308	---	---
5535		CAM ÇİTASI PROFİLİ	0,305	---	---
5536		CAM ÇİTASI PROFİLİ	0,312	---	---
5537		CAM ÇİTASI PROFİLİ	0,318	---	---
5538		CAM ÇİTASI PROFİLİ	0,325	---	---
5539		CAM ÇİTASI PROFİLİ	0,331	---	---
5127		KÖŞE TAKOZ PROFİLİ	3,484	---	---



COD Code	PROFİL KESİTİ Profile View	PROFİL AÇIKLAMASI Profile Description	AGIRLIK (kg/m) Weight	Jxx cm ⁴	Jyy cm ⁴
5128		KÖŞE TAKOZ PROFİLİ	3,652	---	---
5129		KÖŞE TAKOZ PROFİLİ	4,618	---	---
5569		" U " BAĞ. PROFİLİ	0,555	---	---
5570		" U " BAĞ. PROFİLİ	0,393	---	---
5571		" U " BAĞ. PROFİLİ	0,772	---	---
4542		KÖŞE TAKOZ PROFİLİ	5,381	---	---
5556		İSPANYOLET PENCERE KANADI	2,166	71,32	18,76
5557		İSPANYOLET KAPI KANADI	2,734	99,70	51,04
5558		DIŞA AÇILIR KAPI ADAPTÖRÜ	1,281	27,10	5,46
5559		ADAPTÖRÜ PROFİLİ	0,324	---	---
5560		KÖŞE DÖNÜŞ PROFİLİ	1,568	25,21	25,90



E 74

E4

PROFİLLER *PROFILES*

E 74 - 1.8T - E4 YALITIMLI SERİ
E 74 - 1.8T - E4 INSULATION SERIES



COD Code	AGIRLIK (kg/m) Weight	Jxx cm ⁴	Jyy cm ⁴	L m
5500	1,311	32,04	3,74	6
5501	1,651	41,19	10,54	6
5502	2,063	54,33	28,10	6

5500

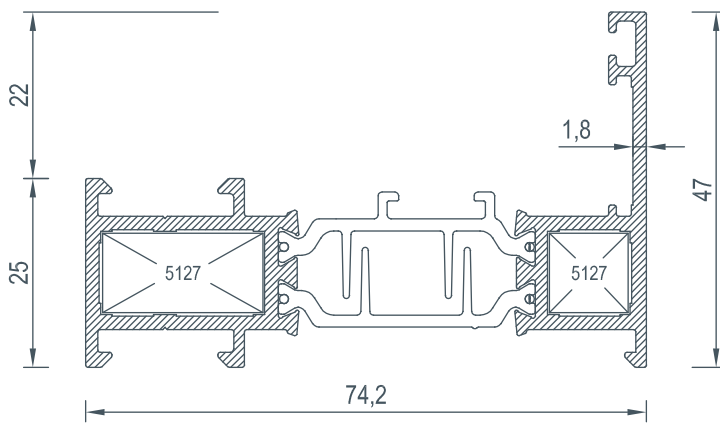

5502

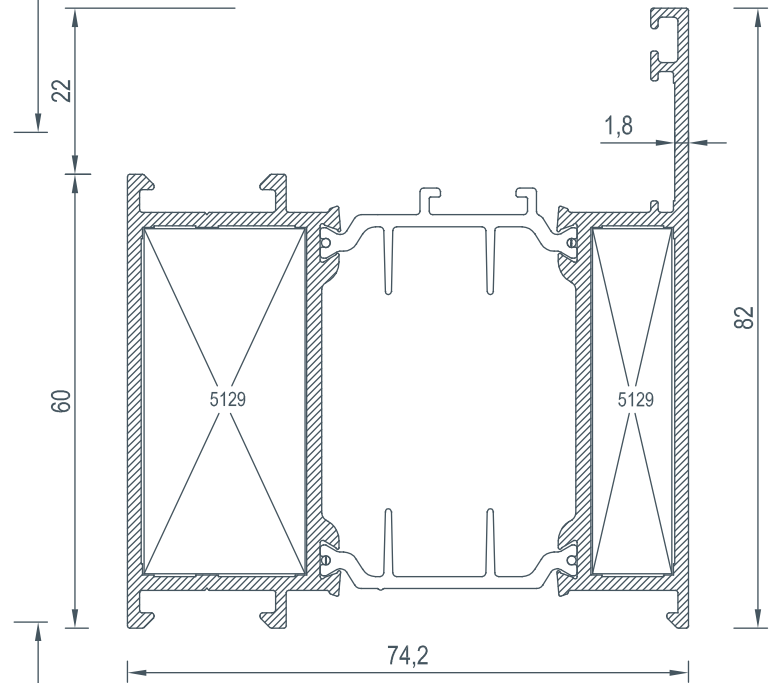

5501

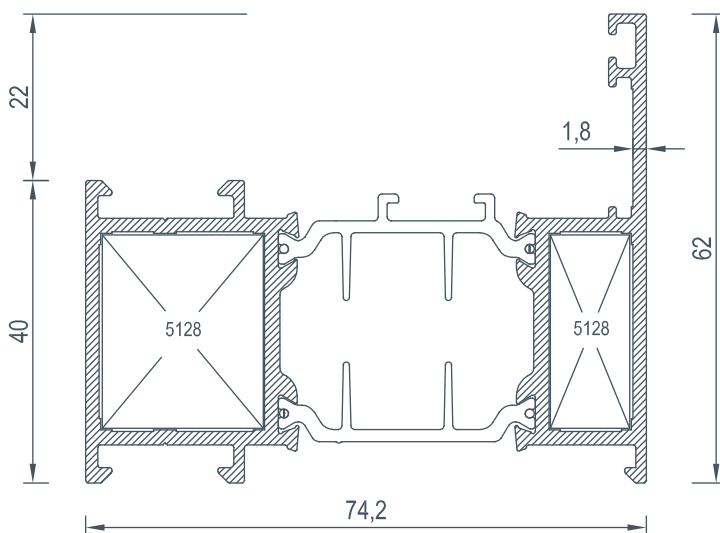

COD Code	AGIRLIK (kg/m) Weight	Jxx cm ⁴	Jyy cm ⁴	L m
5503	1,607	48,33	4,25	6
5504	1,945	61,76	12,93	6

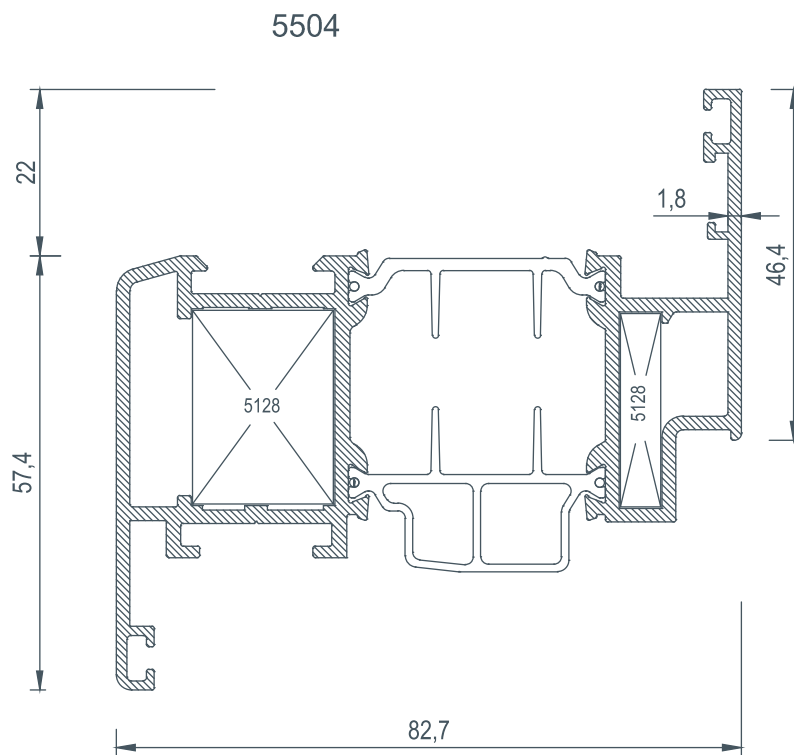
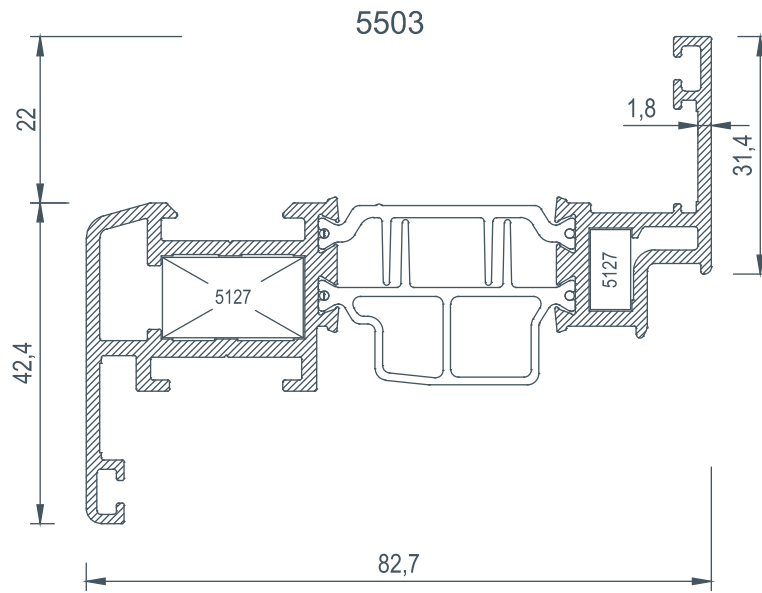

COD Code	AGIRLIK (kg/m) Weight	Jxx cm4	Jyy cm4	L m
5556	2,166	71,32	18,76	6
5557	2,734	99,70	51,04	6

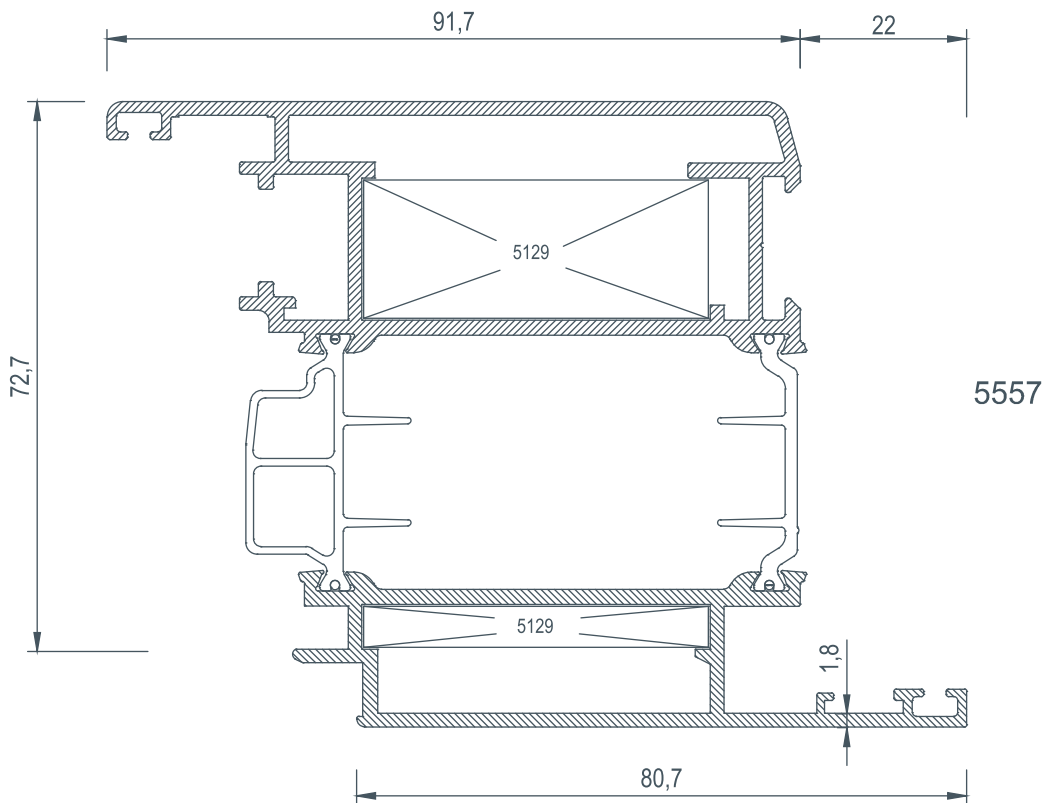
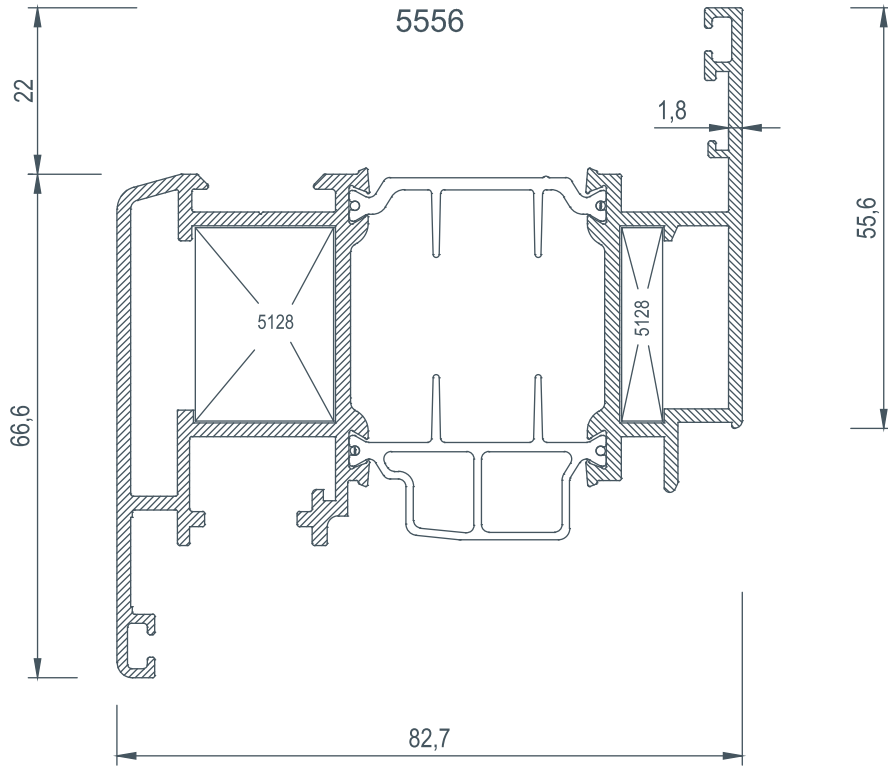

COD Code	AGIRLIK (kg/m) Weight	Jxx cm ⁴	Jyy cm ⁴	L m
5568	2,659	97,83	52,43	6
5506	2,469	72,96	48,31	6

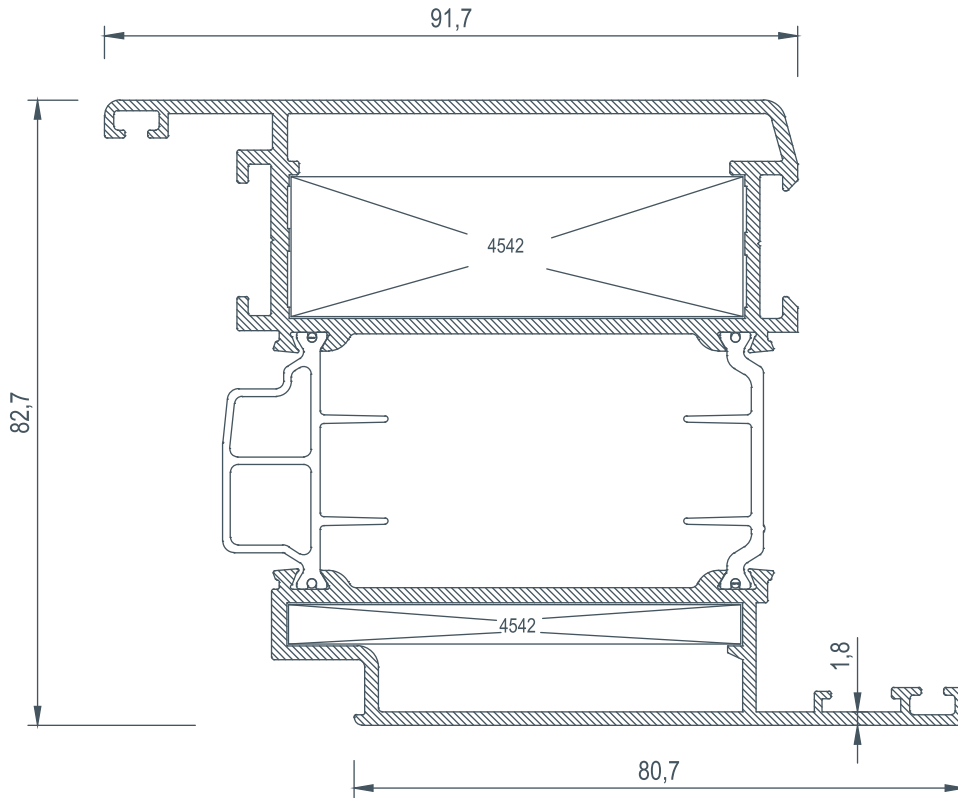

5568

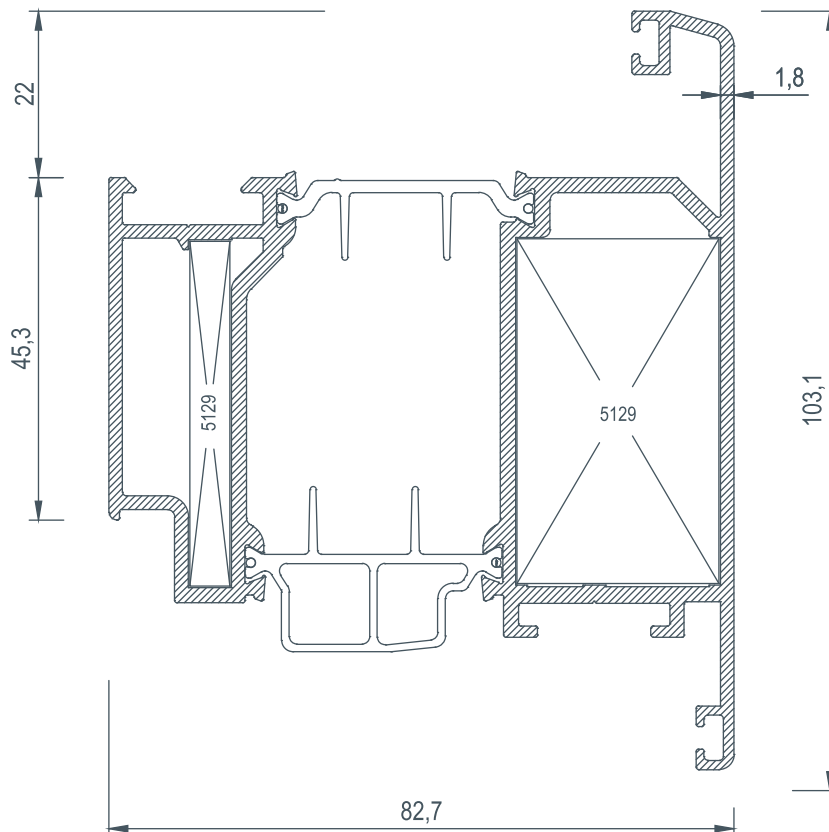

5506



COD Code	AGIRLIK (kg/m) Weight	Jxx cm ⁴	Jyy cm ⁴	L m ← →
5507	1,468	35,71	7,96	6
5508	1,808	45,21	17,37	6
5509	2,220	57,40	39,90	6
5510	1,881	47,93	17,70	6

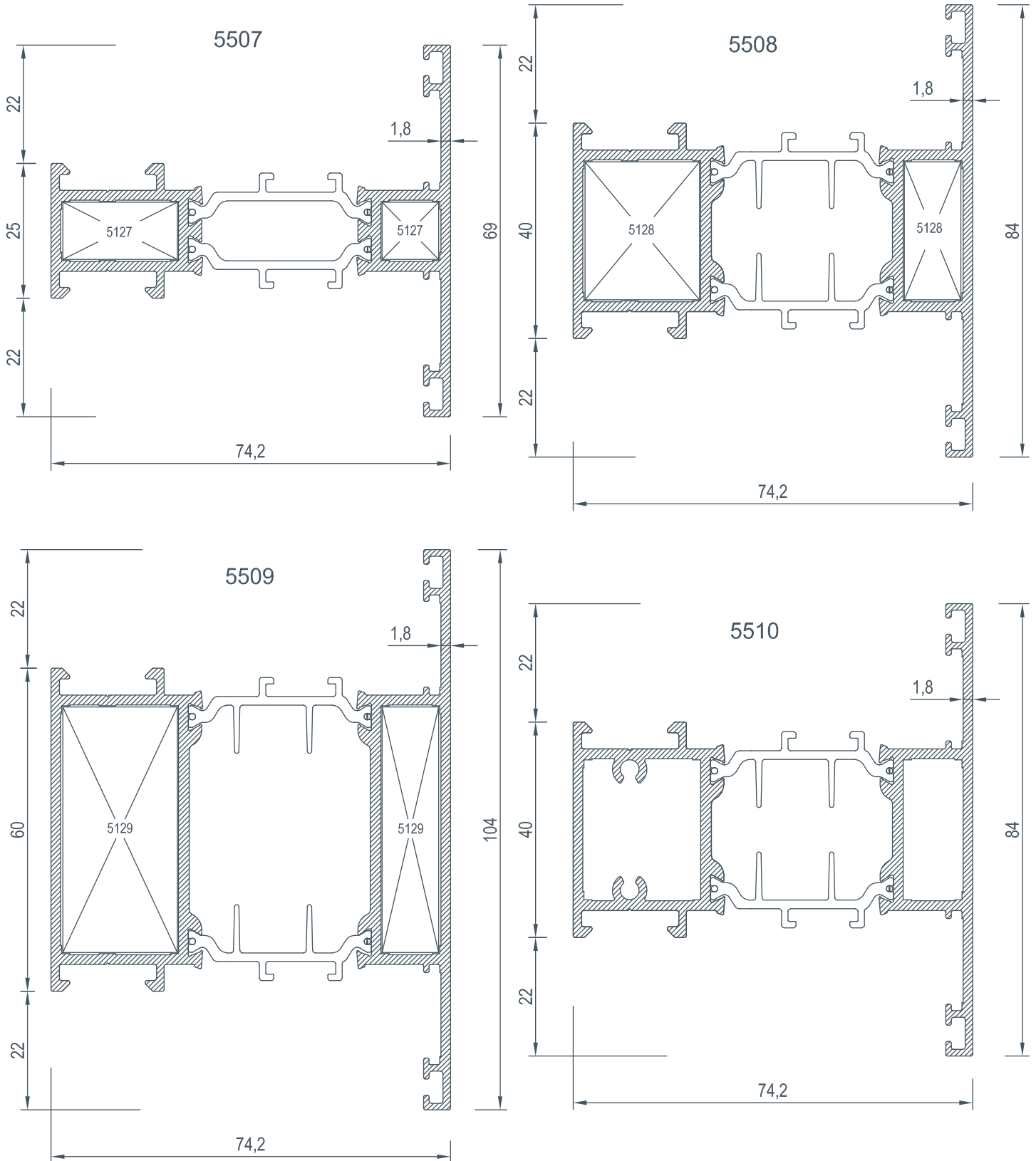



COD Code	AGIRLIK (kg/m) Weight	Jxx cm ⁴	Jyy cm ⁴	L m
5511	2,522	101,22	29,33	6
5512	2,724	177,13	26,77	6

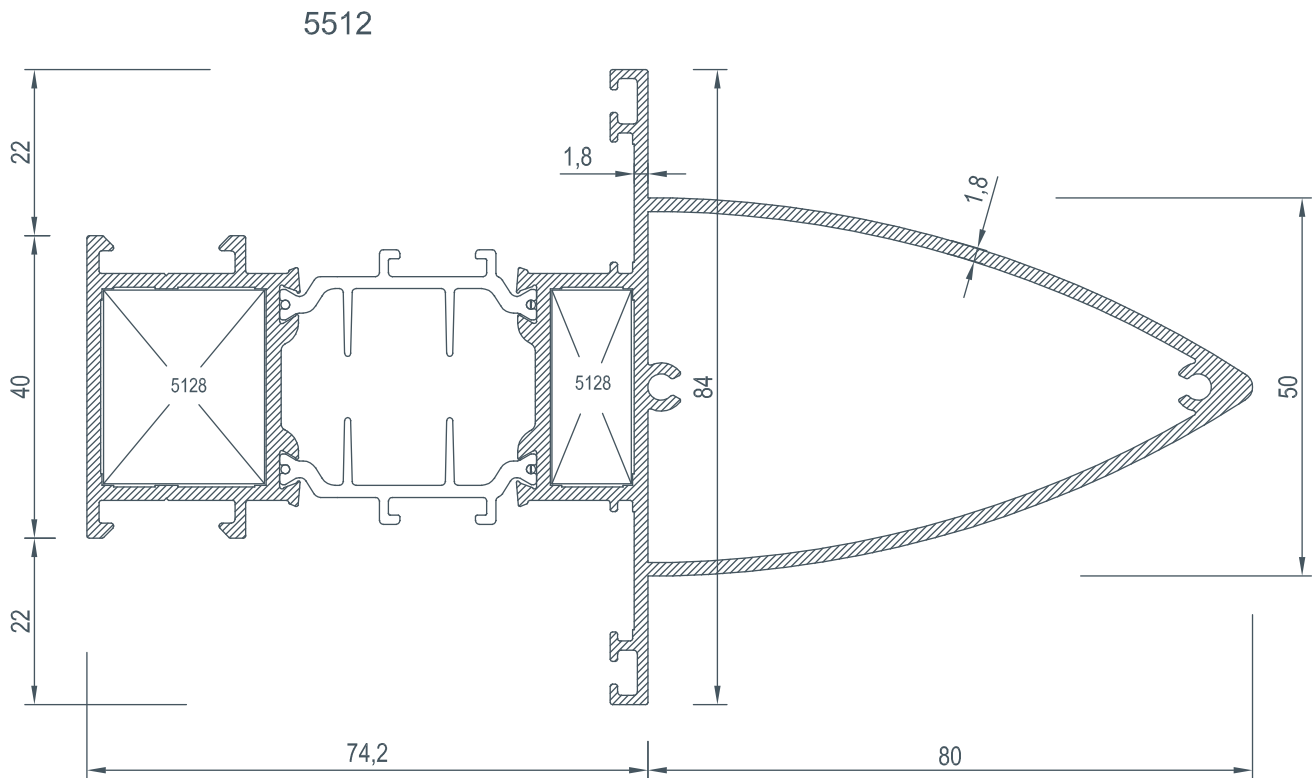
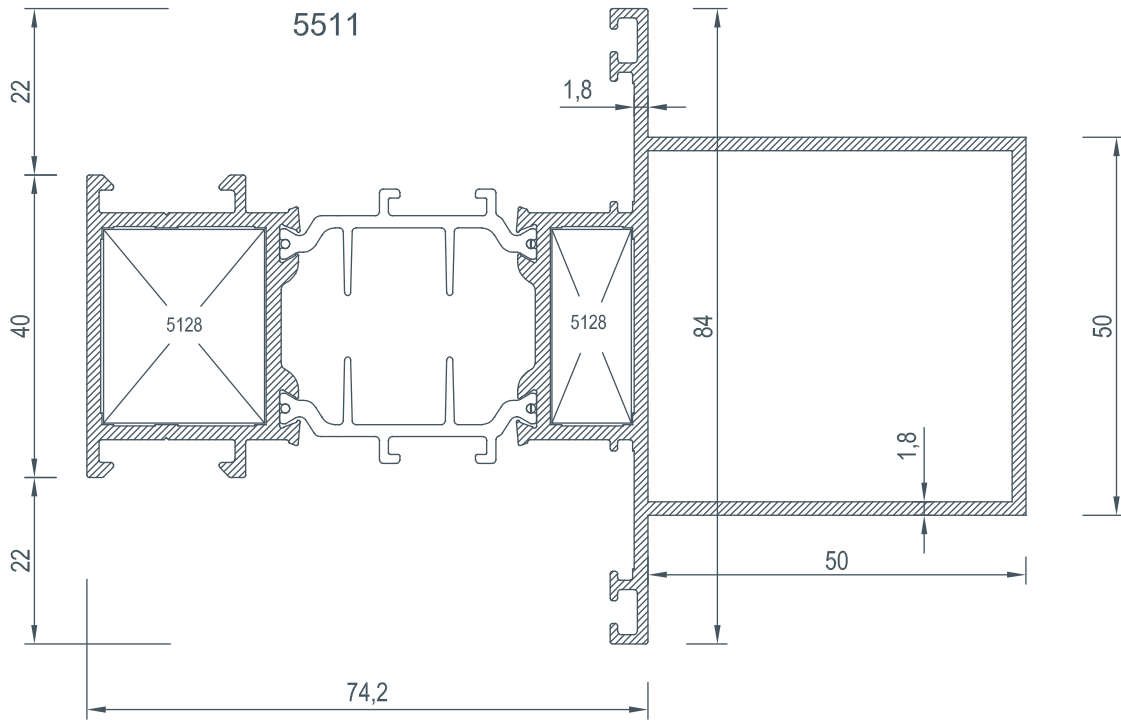



COD Code	AGIRLIK (kg/m) Weight	Jxx cm ⁴	Jyy cm ⁴	L m
5513	2,660	89,43	69,49	6

5513

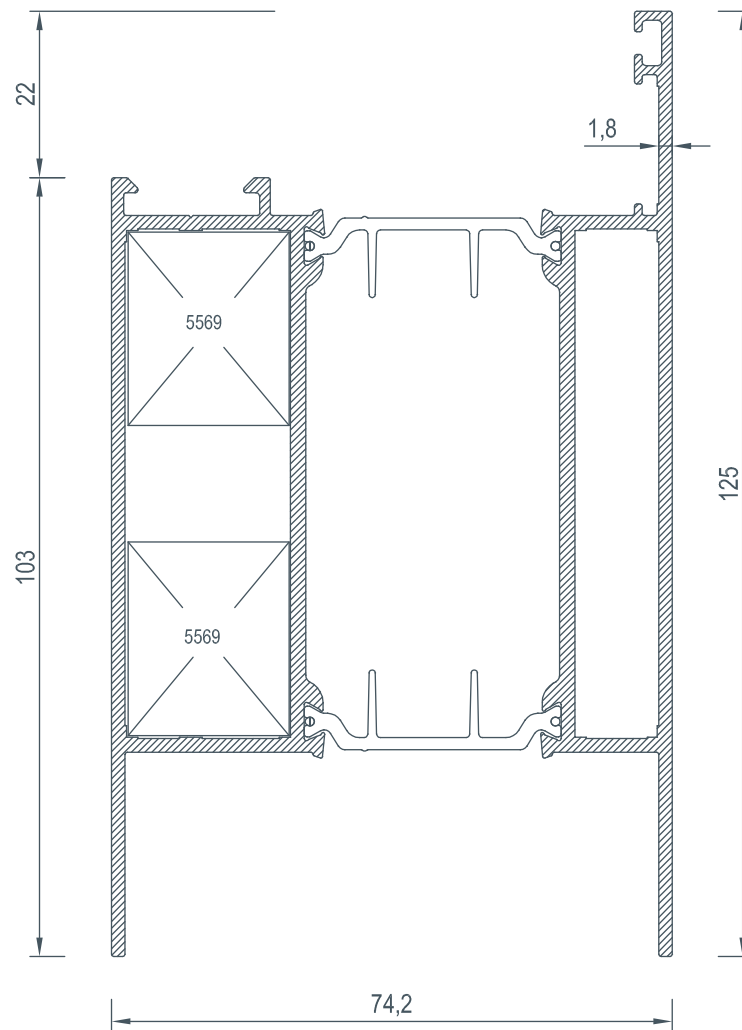



COD Code	AGIRLIK (kg/m) Weight	Jxx cm ⁴	Jyy cm ⁴	L m
5514	1,540	35,15	8,37	6
5515	1,642	27,52	10,66	6
5117	0,105	---	----	6
5558	1,281	27,10	5,46	6
5572	0,100	----	----	6

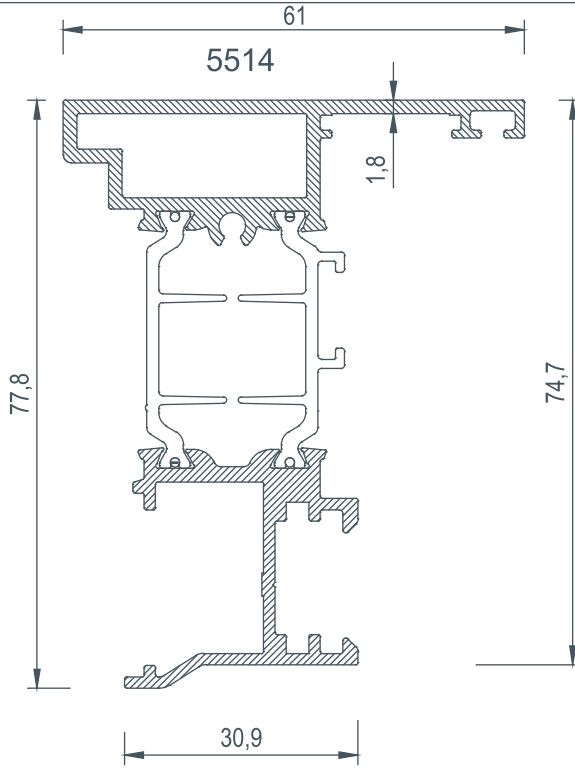

5117



5572
(BOYALI TİJ PROFİLİ)

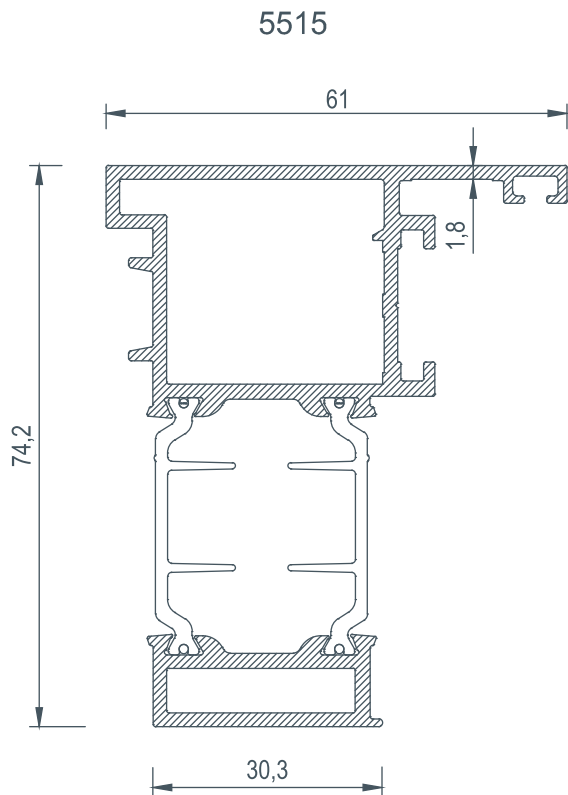

5558

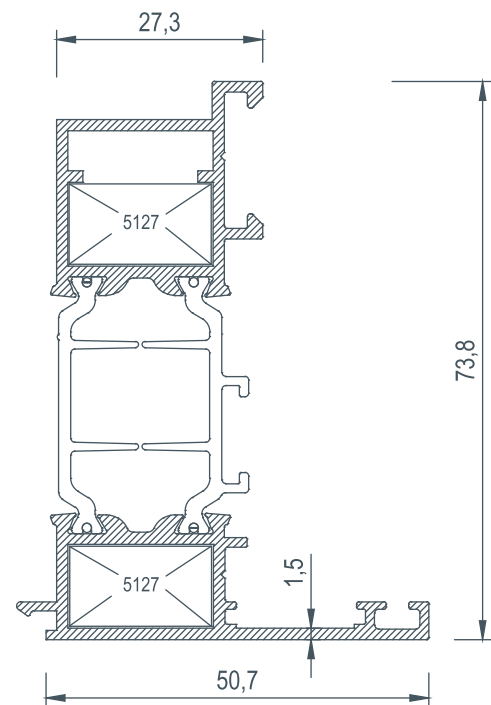



COD Code	AGIRLIK (kg/m) Weight	Jxx cm ⁴	Jyy cm ⁴	L m
5516	2,141	61,27	40,77	6
5559	0,324	----	---	6
5560	1,568	25,21	25,90	6
5561	0,471	----	---	6
5337	0,151	----	---	6

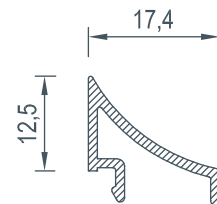
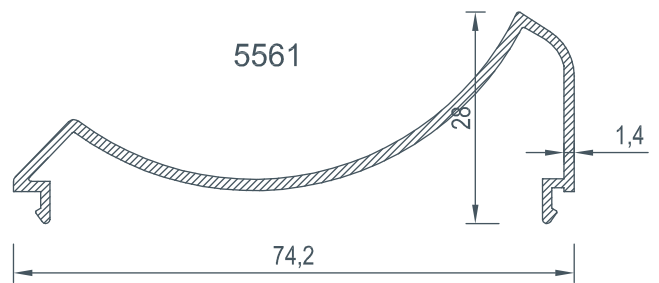
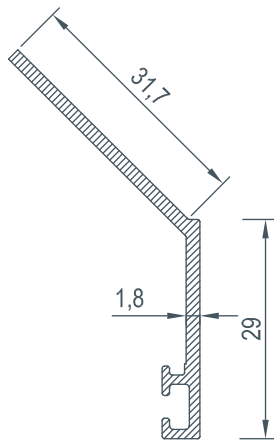
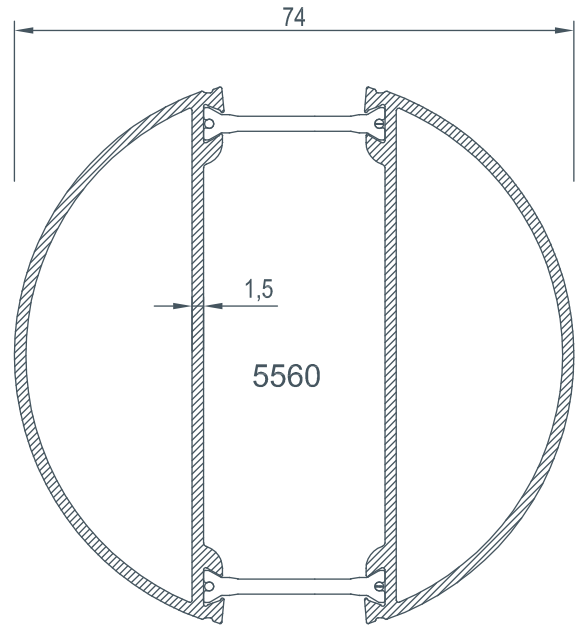
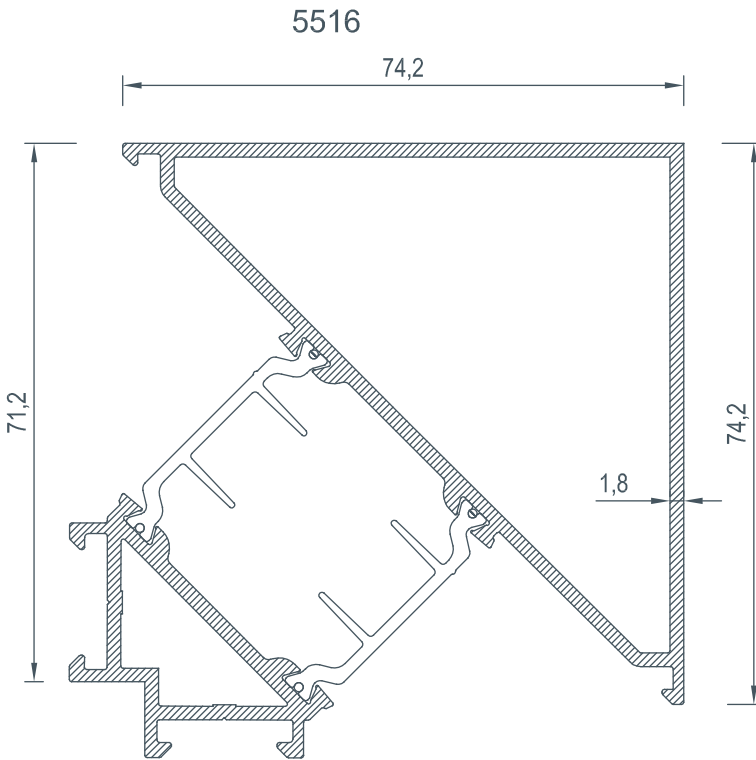

5559

5337



COD Code	AGIRLIK (kg/m) Weight	Jxx cm4	Jyy cm4	L m
5118	0,249	-----	-----	6
5119	0,251	-----	-----	6
5120	0,254	-----	-----	6
5121	0,259	-----	-----	6
5122	0,267	-----	-----	6
5123	0,274	-----	-----	6
5124	0,281	-----	-----	6
5125	0,292	-----	-----	6
5126	0,308	-----	-----	6
5535	0,305	-----	-----	6

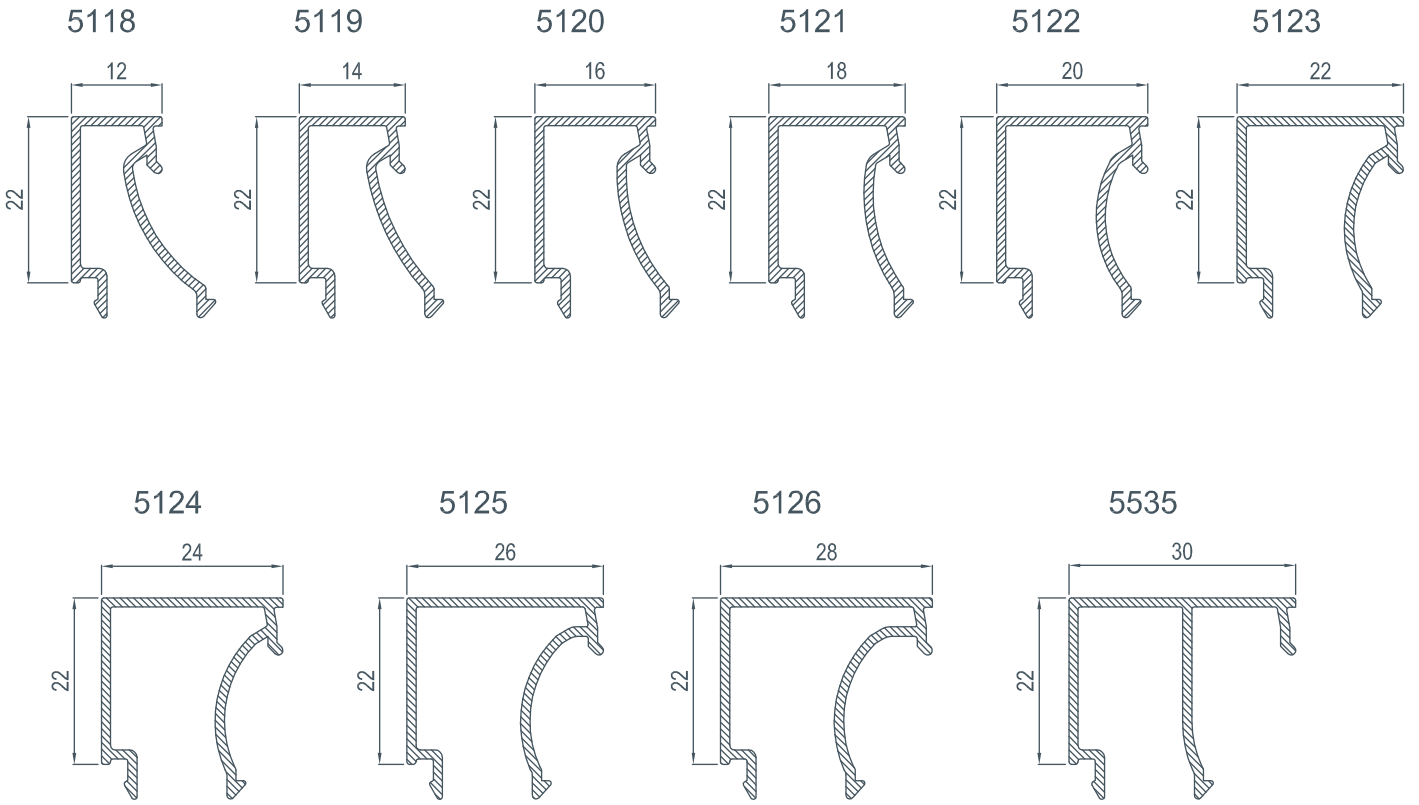

CAM ÇİTASI Glazing Bead	İÇ CAM FİTİLİ Glazing Gasket (in)	CAM KALINLIĞI Glas Thickness	DIŞ CAM FİTİLİ Glazing Gasket (out)
5118	E-01-001	50 mm	E-01-028
5119	E-01-001	48 mm	E-01-028
5120	E-01-001	46 mm	E-01-028
5121	E-01-001	44 mm	E-01-028
5122	E-01-001	42 mm	E-01-028
5123	E-01-001	40 mm	E-01-028
5124	E-01-001	38 mm	E-01-028
5125	E-01-001	36 mm	E-01-028
5126	E-01-001	34 mm	E-01-028
5535	E-01-001	32 mm	E-01-028



COD Code	AGIRLIK (kg/m) Weight	Jxx cm ⁴	Jyy cm ⁴	L m
5536	0,312	-----	-----	6
5537	0,318	-----	-----	6
5538	0,325	-----	-----	6
5539	0,331	-----	-----	6

5536

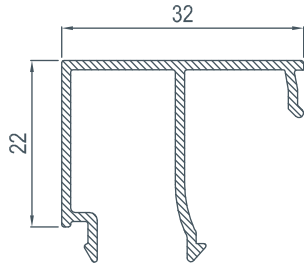

5537

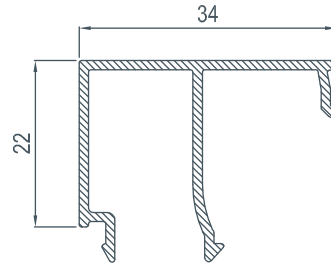

5538

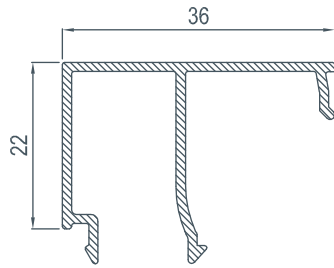

5539

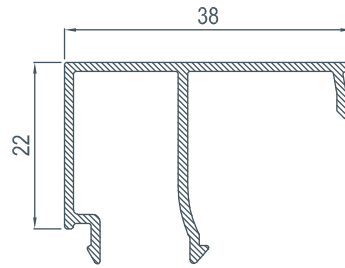

CAM ÇİTASI Glazing Bead	İÇ CAM FİTİLİ Glazing Gasket (in)	CAM KALINLIĞI Glas Thickness	DIŞ CAM FİTİLİ Glazing Gasket (out)
5536	E-01-001	30 mm	E-01-028
5537	E-01-001	28 mm	E-01-028
5538	E-01-001	26 mm	E-01-028
5539	E-01-001	24 mm	E-01-028



COD Code	AGIRLIK (kg/m) Weight	Jxx cm ⁴	Jyy cm ⁴	L m
5127	3,484	---	---	6

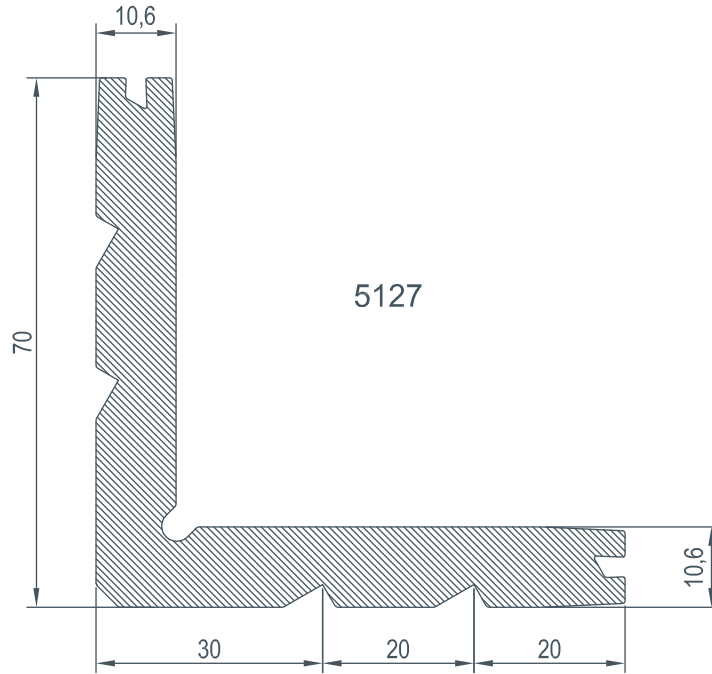

KÖŞE TAKOZLARI / Corner Cleats

Nr	L m	AKS. KODU Acs. Code	KESİM ÖLÇÜSÜ Cutting Size
5500	5127	5127-21,3	21,3 mm
	5127	5127-10,5	10,5 mm
5503	5127	5127-18,6	18,6 mm
	5127	5127-5,3	5,3 mm
5507	5127	5127-21,3	21,3 mm
	5127	5127-10,5	10,5 mm



COD Code	AGIRLIK (kg/m) Weight	Jxx cm ⁴	Jyy cm ⁴	L m
5128	3,652	---	---	6

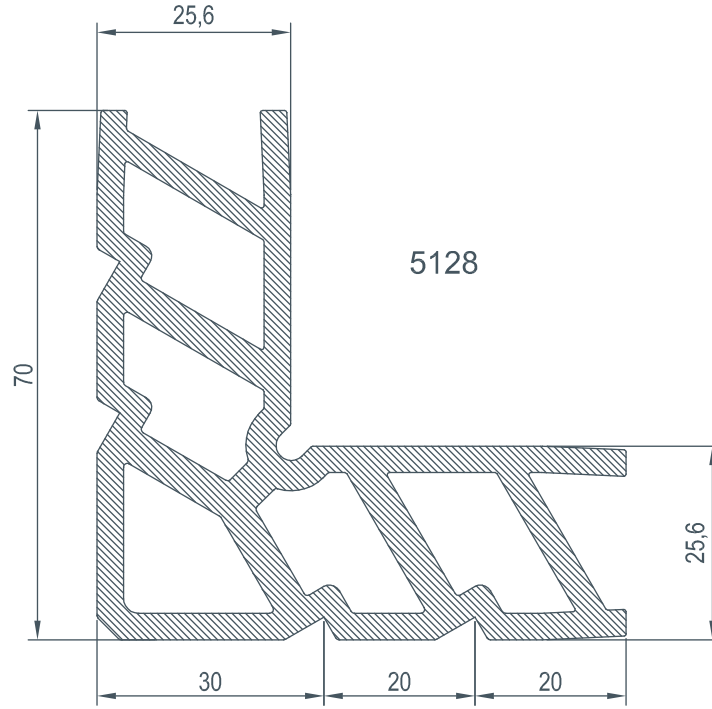

KÖŞE TAKOZLARI / Corner Cleats

Nr	AKS. KODU Acs. Code	KESİM ÖLÇÜSÜ Cutting Size
5501	5128-21,3	21,3 mm
	5128-10,5	10,5 mm
5504	5128-18,6	18,6 mm
	5128-5,3	5,3 mm
5508	5128-21,3	21,3 mm
	5128-10,5	10,5 mm
5510	---	---
	5128-10,5	10,5 mm
5511	5128-21,3	21,3 mm
	5128-10,5	10,5 mm
5512	5128-21,3	21,3 mm
	5128-10,5	10,5 mm
5556	5128-18,3	18,3 mm
	5128-5,4	5,4 mm



COD Code	AGIRLIK (kg/m) Weight	Jxx cm ⁴	Jyy cm ⁴	L m
5129	4,618	---	---	6

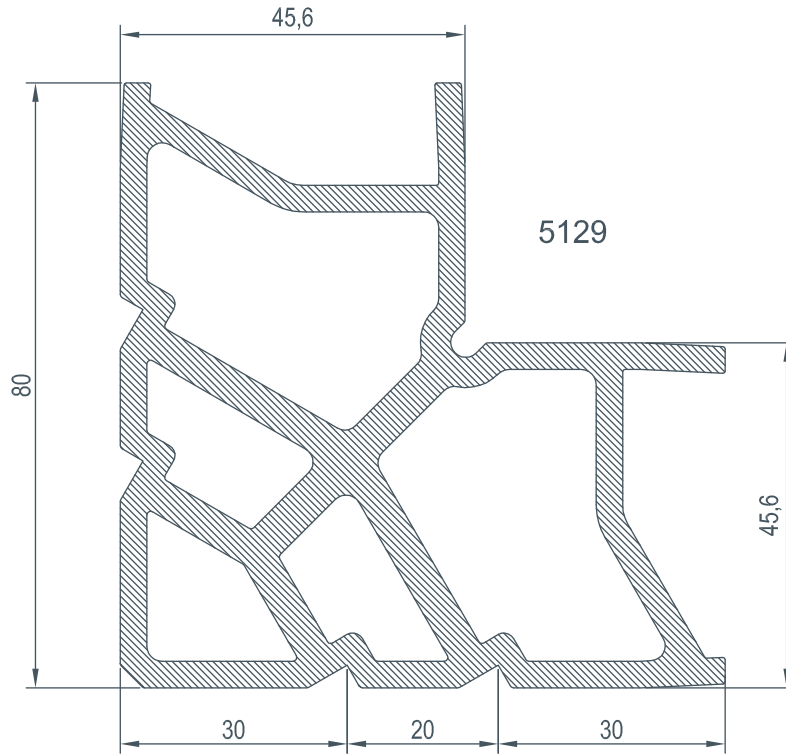



KÖŞE TAKOZLARI / Corner Cleats

Nr	 L m	AKS. KODU Acs. Code	KESİM ÖLÇÜSÜ Cutting Size
5502	5129	5129-21,3	21,3 mm
	5129	5129-10,5	10,5 mm
5509	5129	5129-21,3	21,3 mm
	5129	5129,10,5	10,5 mm
5506	5129	5129-26,7	26,7 mm
	5129	5129-5,3	5,3 mm
5557	5129	5129-18,3	18,3 mm
	5129	5129-5,4	5,4 mm

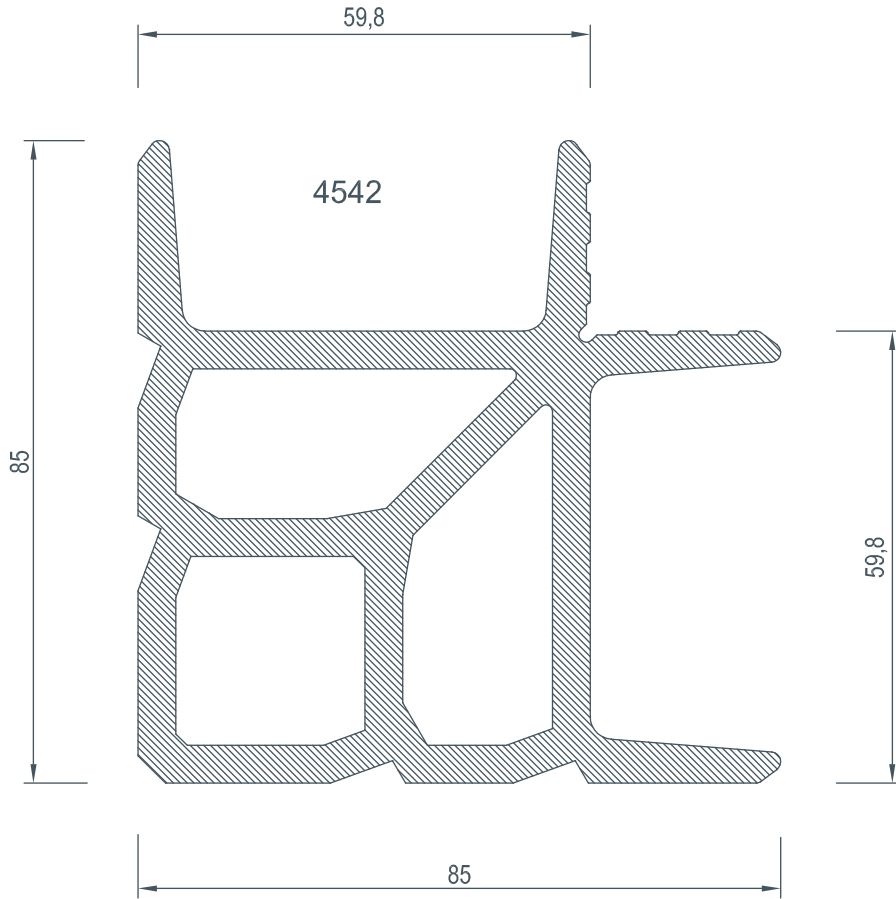

COD Code	AGIRLIK (kg/m) Weight	Jxx cm ⁴	Jyy cm ⁴	L m
4542	5,381	---	---	6

**KÖŞE TAKOZLARI / Corner Cleats**

Nr	 L m	AKS. KODU Ac. Code	KESİM ÖLÇÜSÜ Cutting Size
5568	4542	4542-18,6	18,6 mm
	4542	4542-5,3	5,3 mm



COD Code	AGIRLIK (kg/m) Weight	Jxx cm ⁴	Jyy cm ⁴	L m
5569	0,555	---	---	6
5570	0,393	---	---	6
5571	0,772	---	---	6

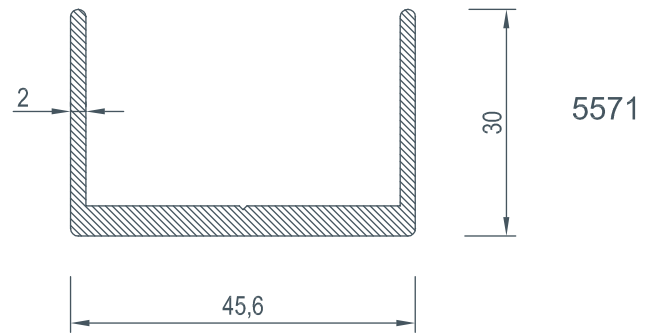
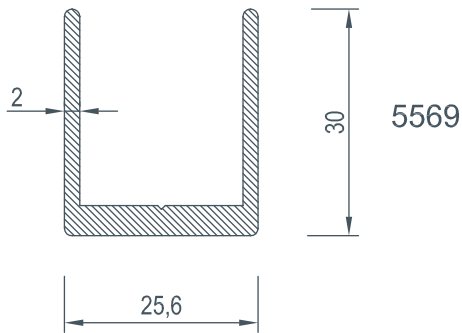
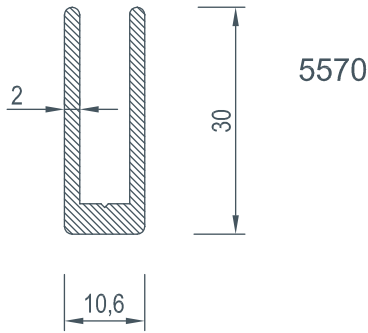

ORTA KAYIT BAĞLANTI / Mullion Connection Piece

Nr	AKS. KODU Acs. Code	KESİM ÖLÇÜSÜ Cutting Size
5507	5570-21,3	21,3 mm
5508	5569-21,3	21,3 mm
5509	5571-21,3	21,3 mm
5510	---	---
5511	5569-45,6	21,3 mm
5512	5569-45,6	21,3 mm
5513	5569-45,6	21,3 mm



E 74

E4

DETAYLAR

DETAILS

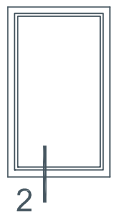
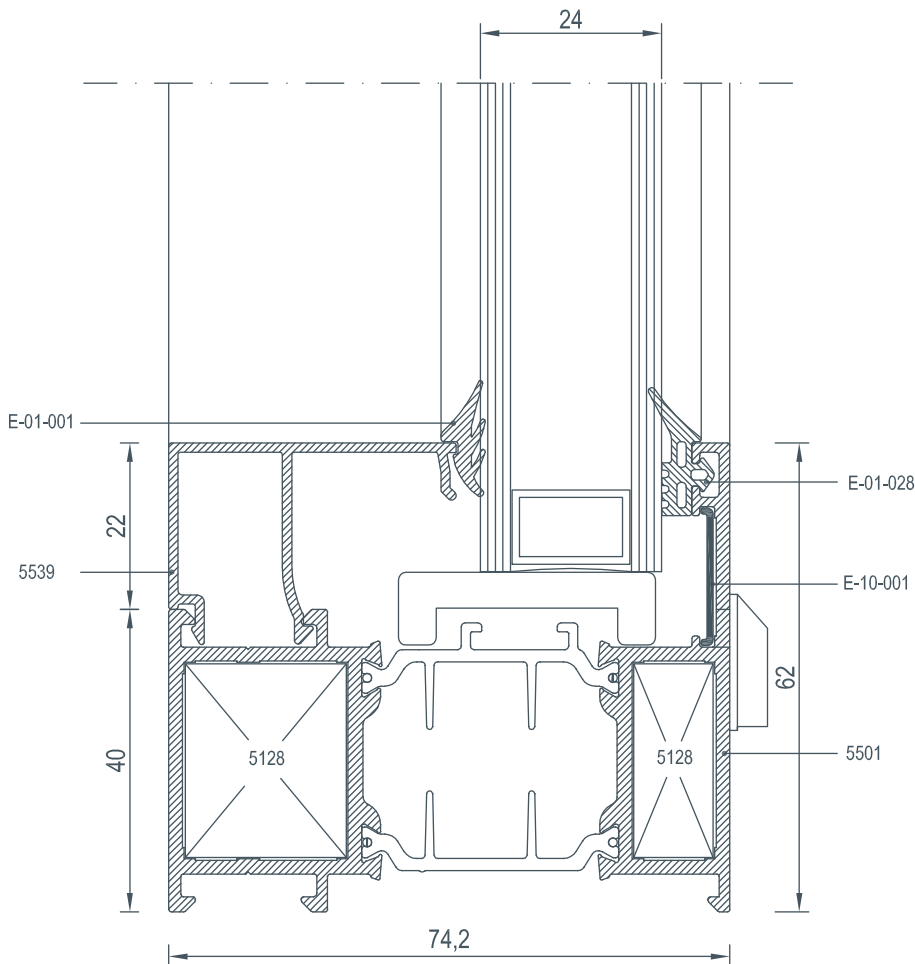
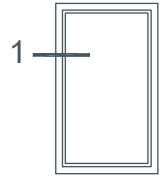
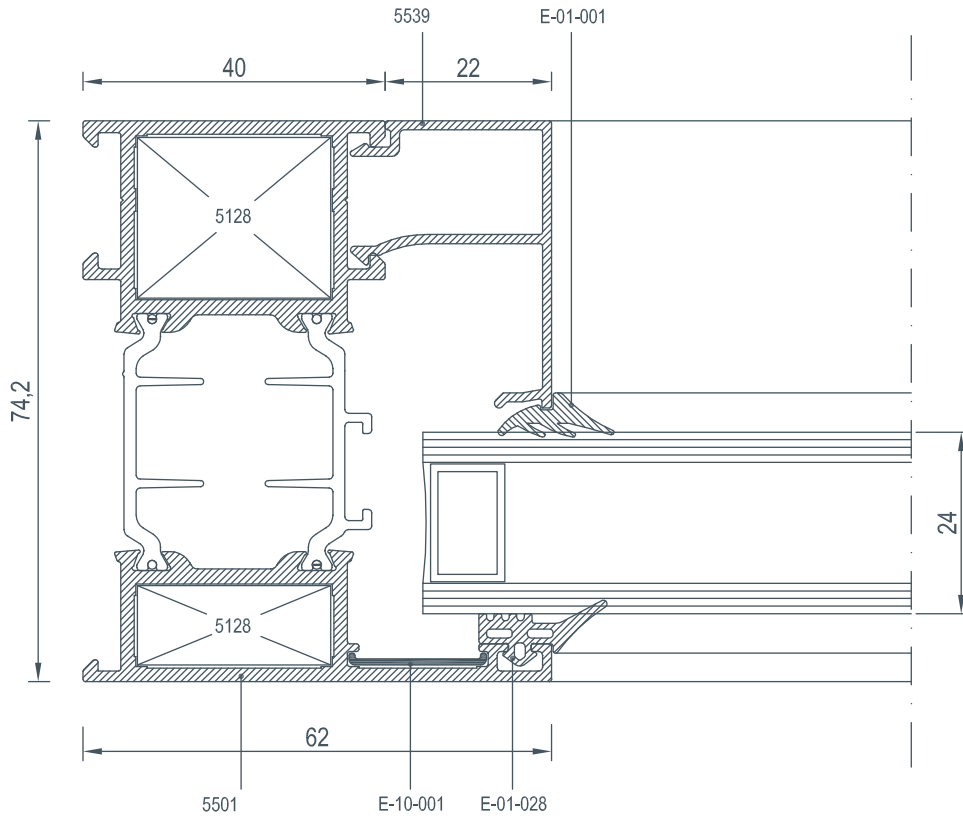



E4

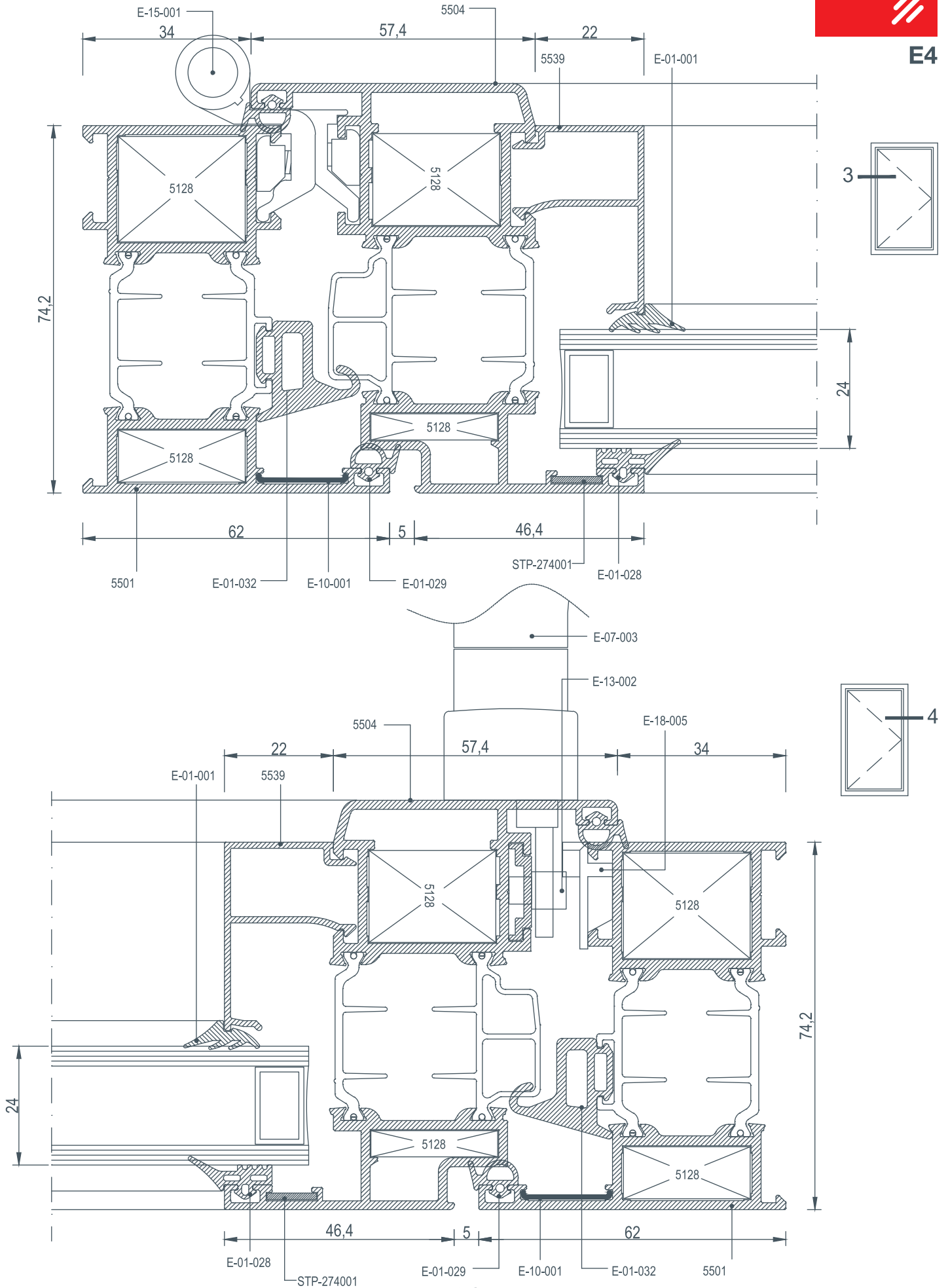

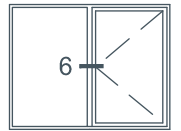
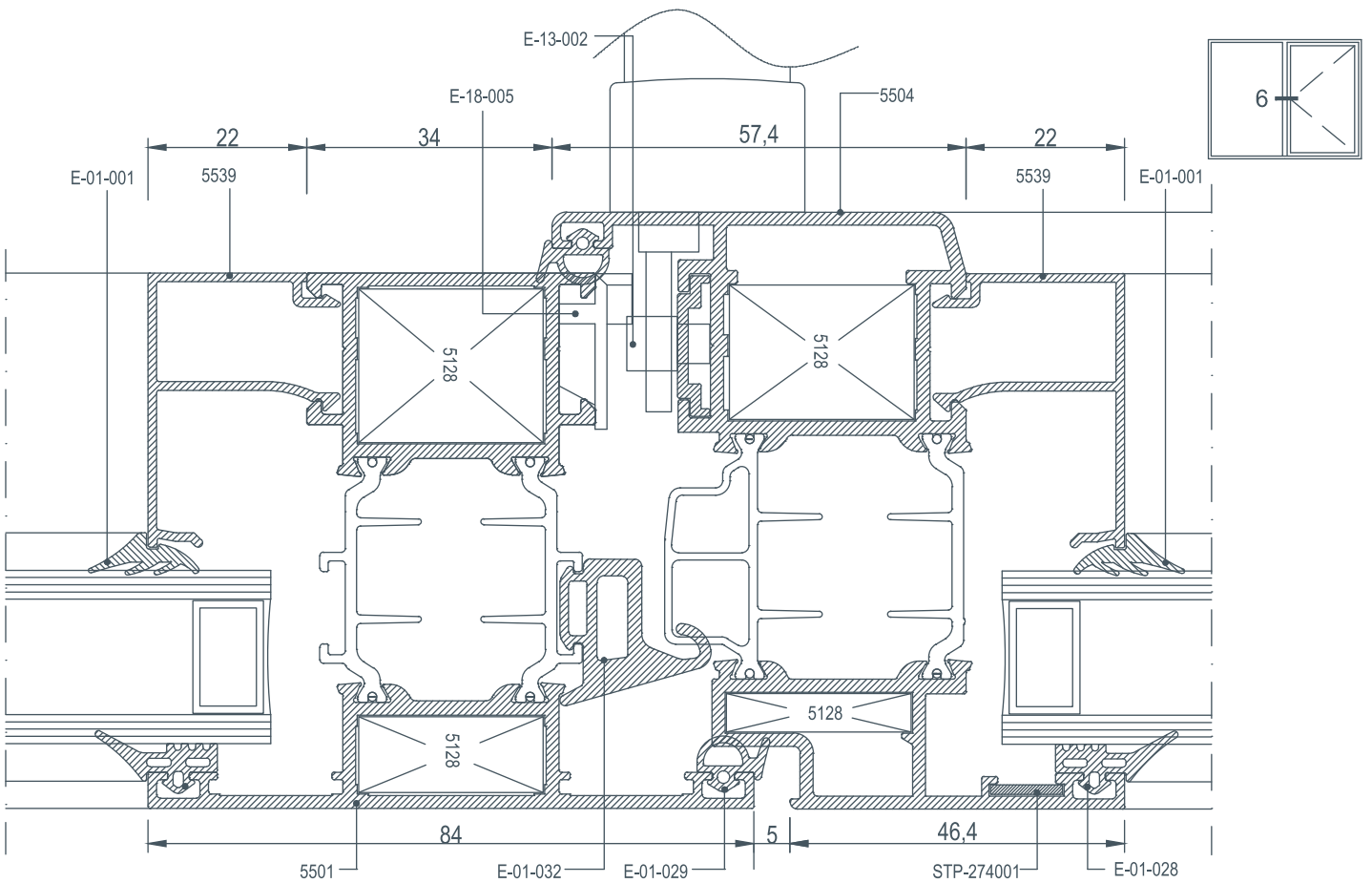
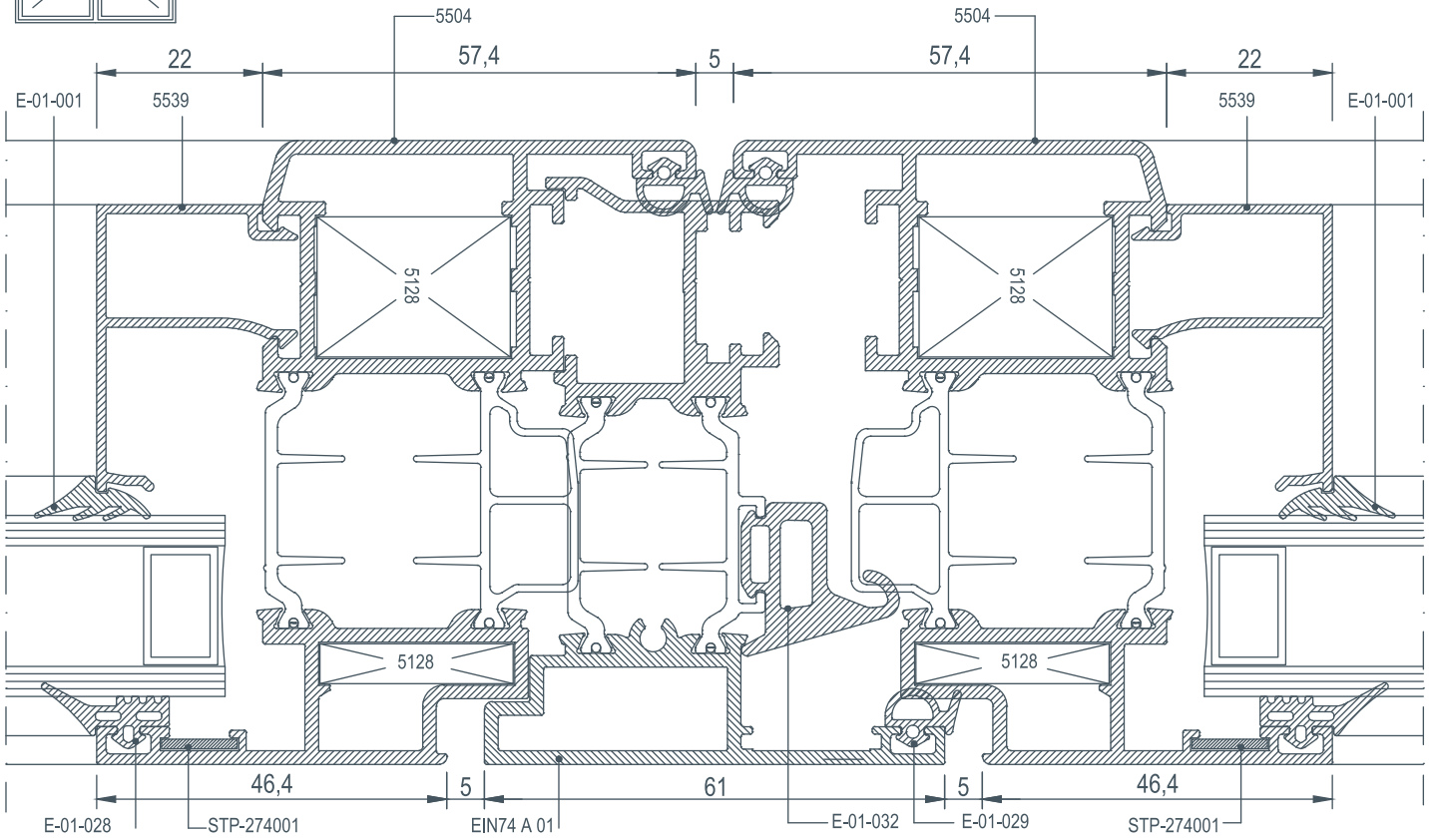
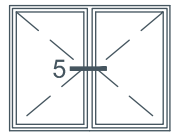

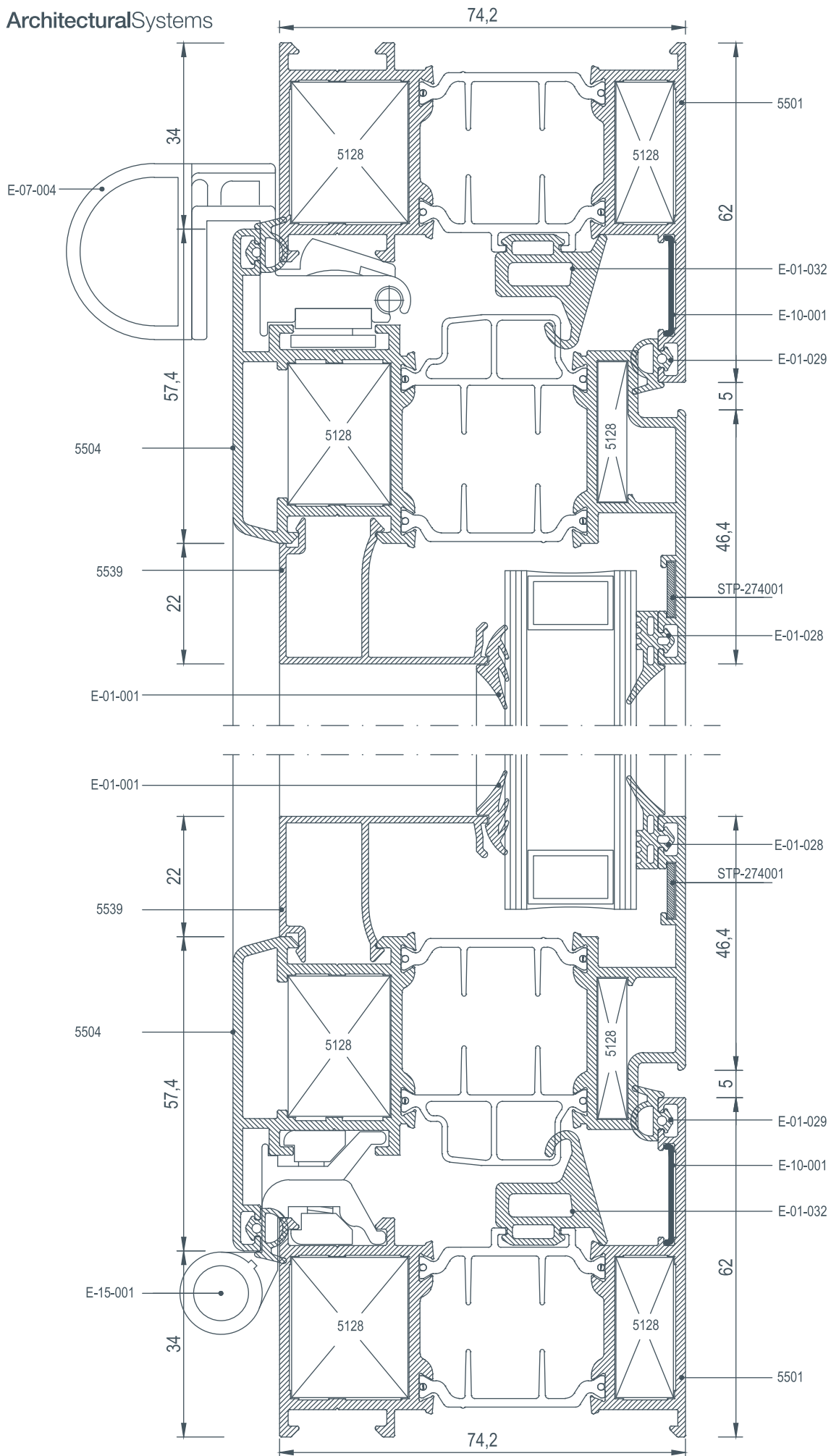

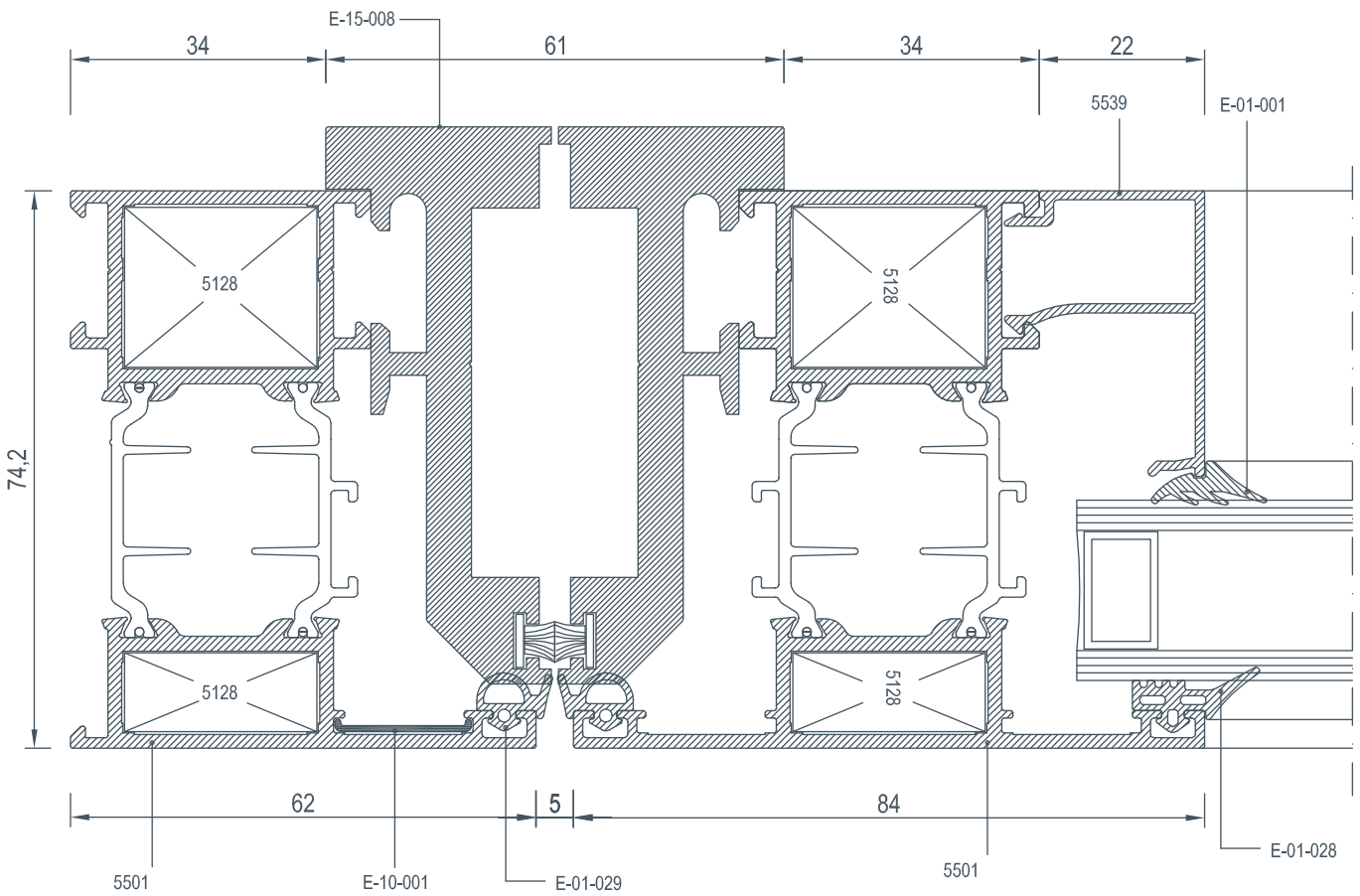
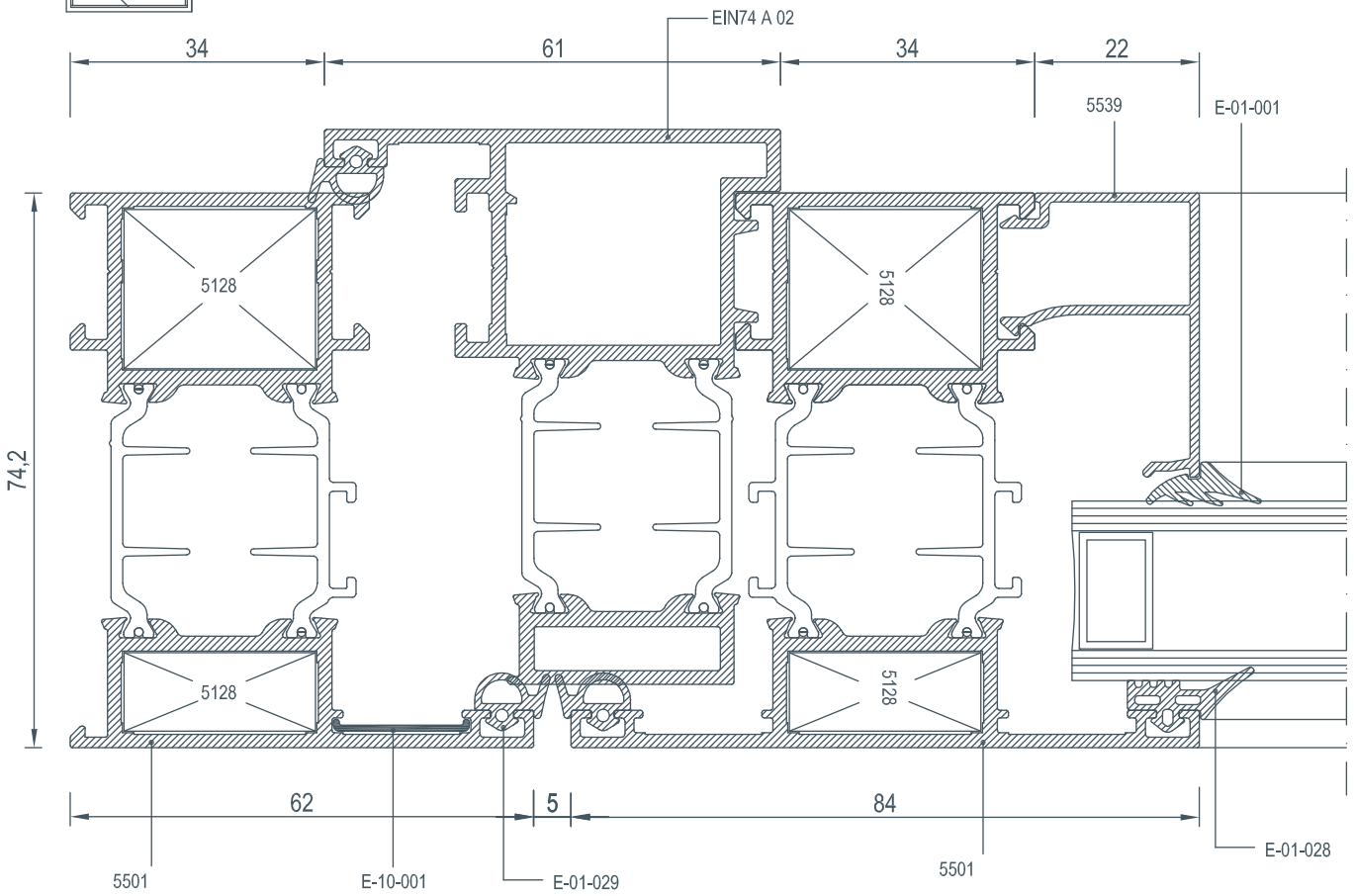
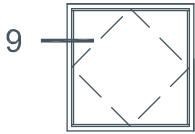

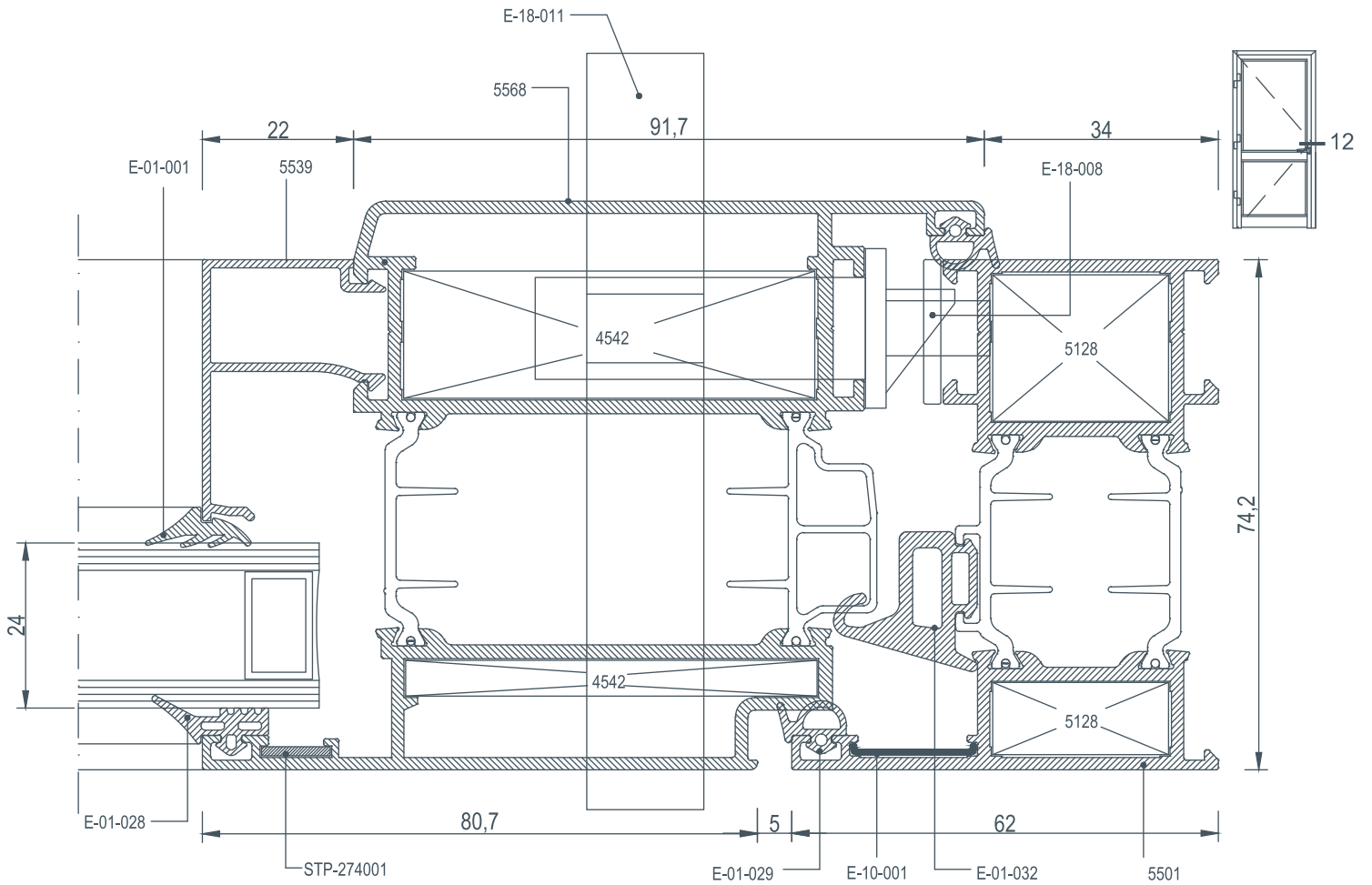
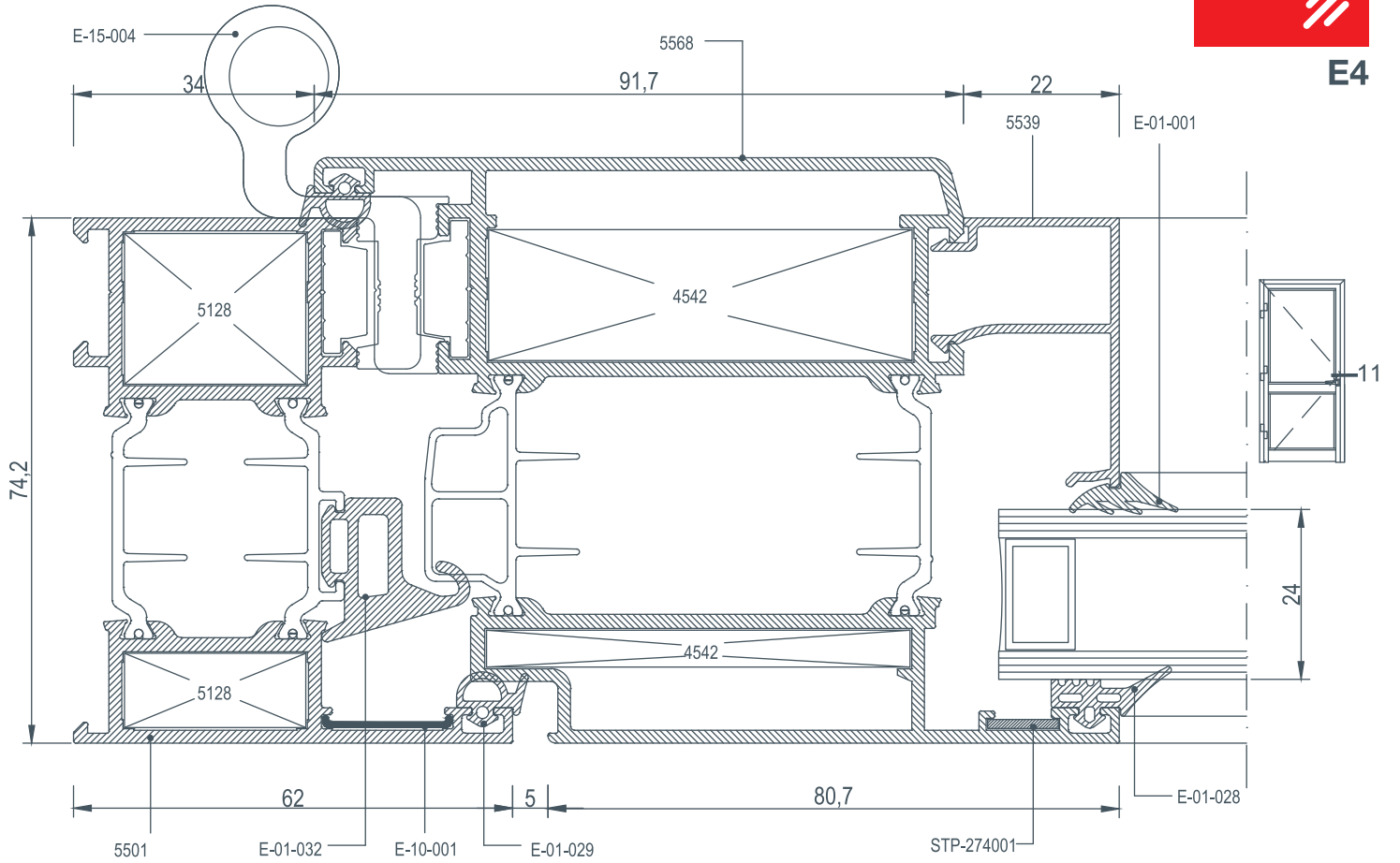

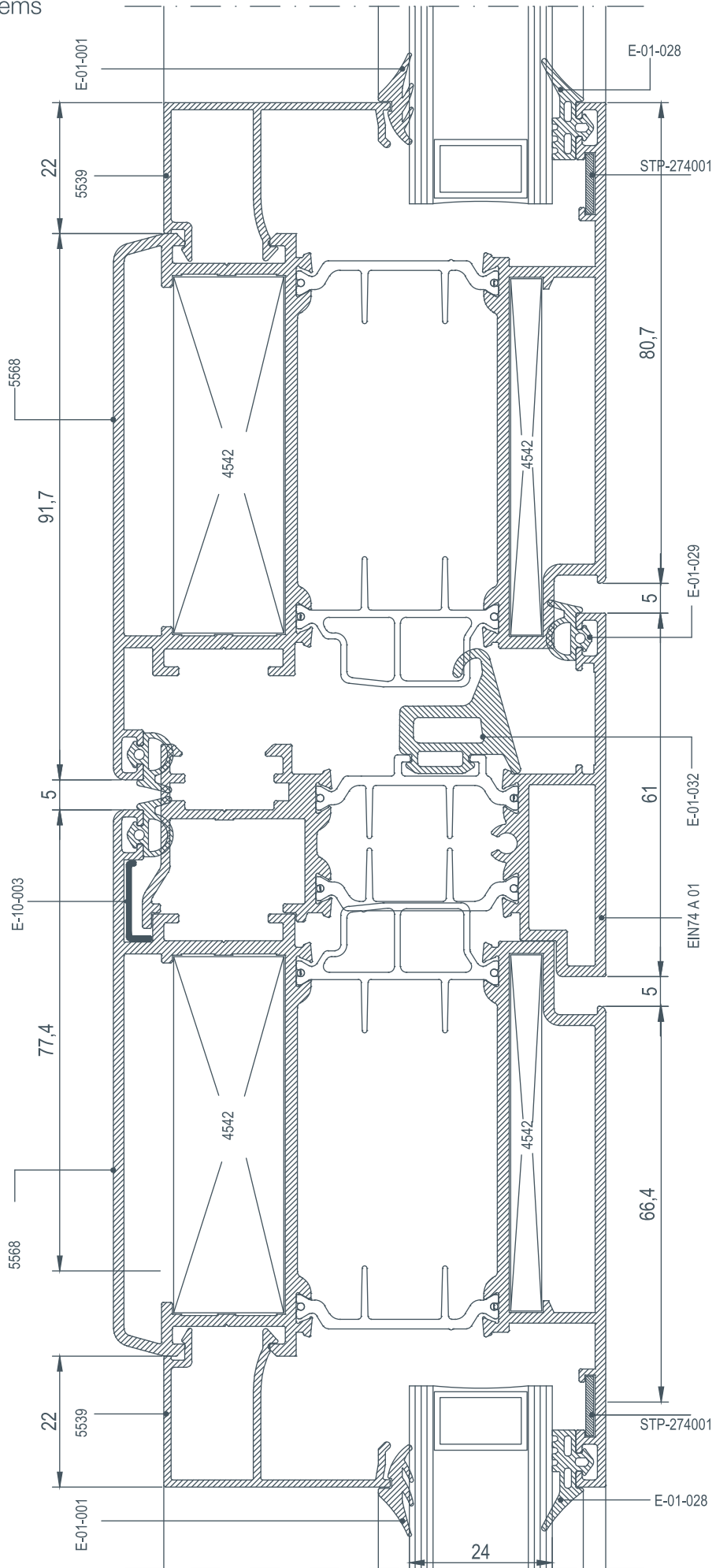
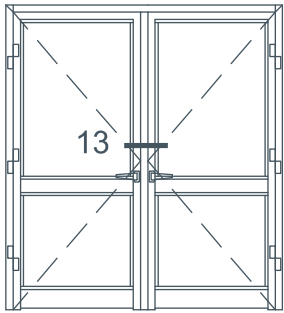

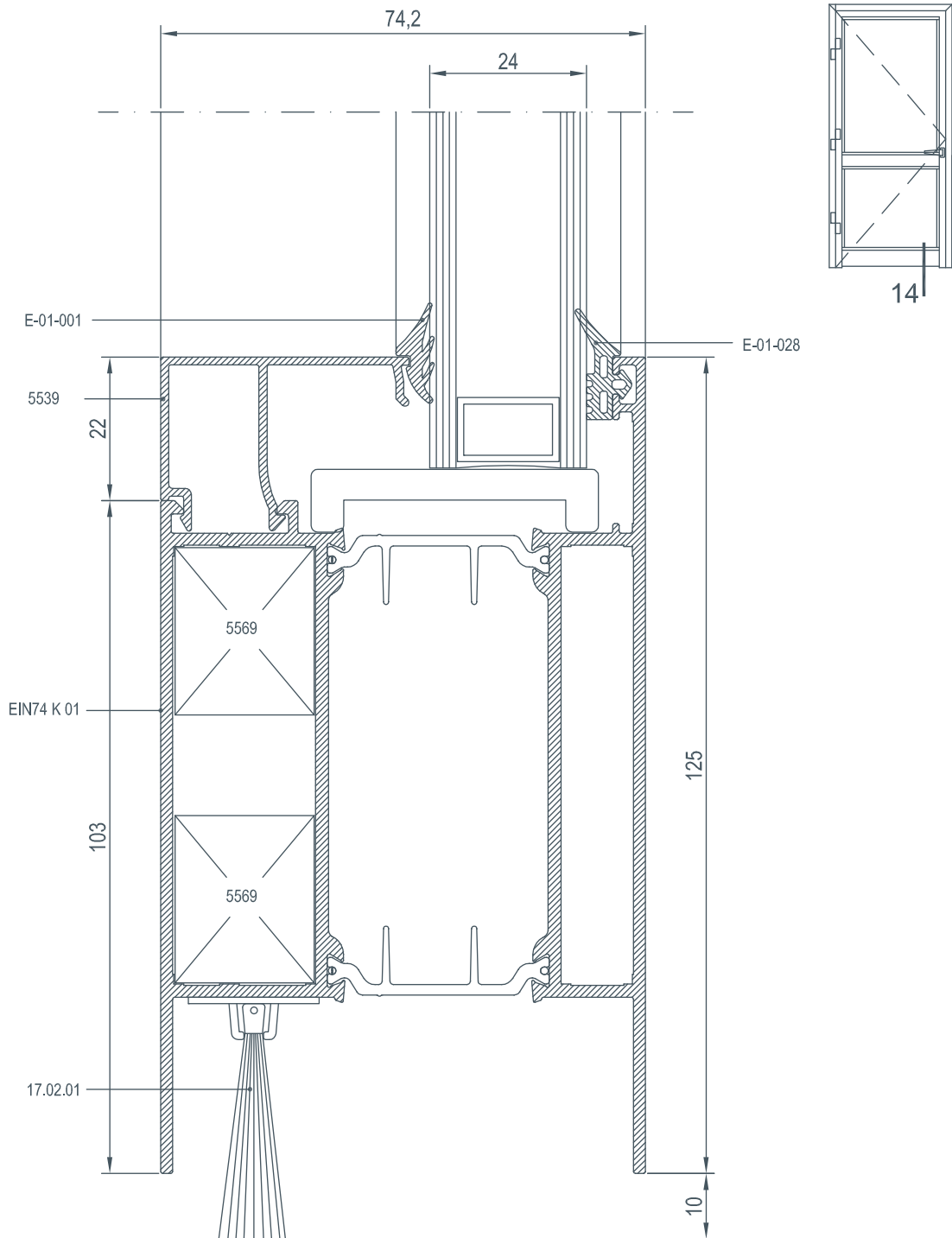

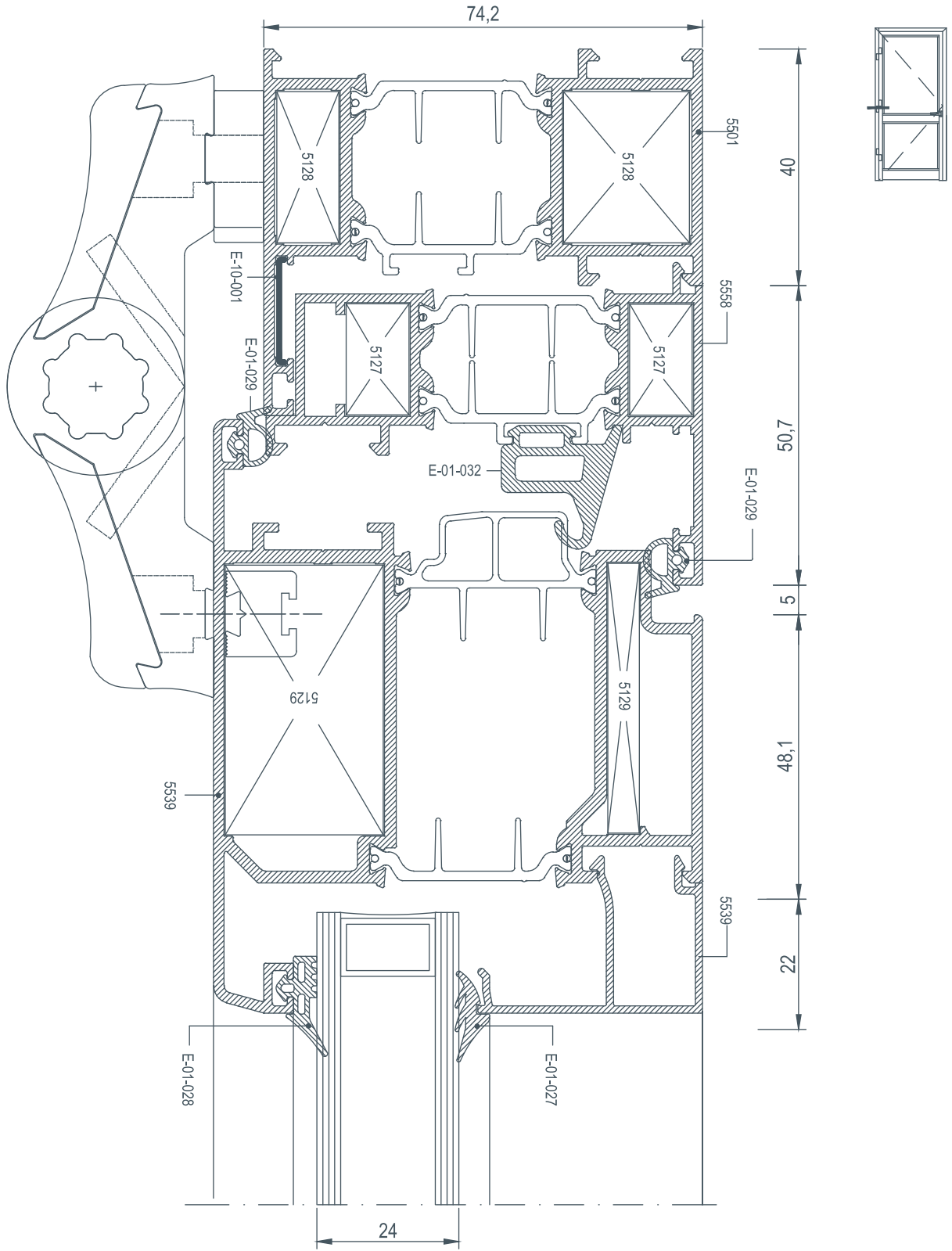

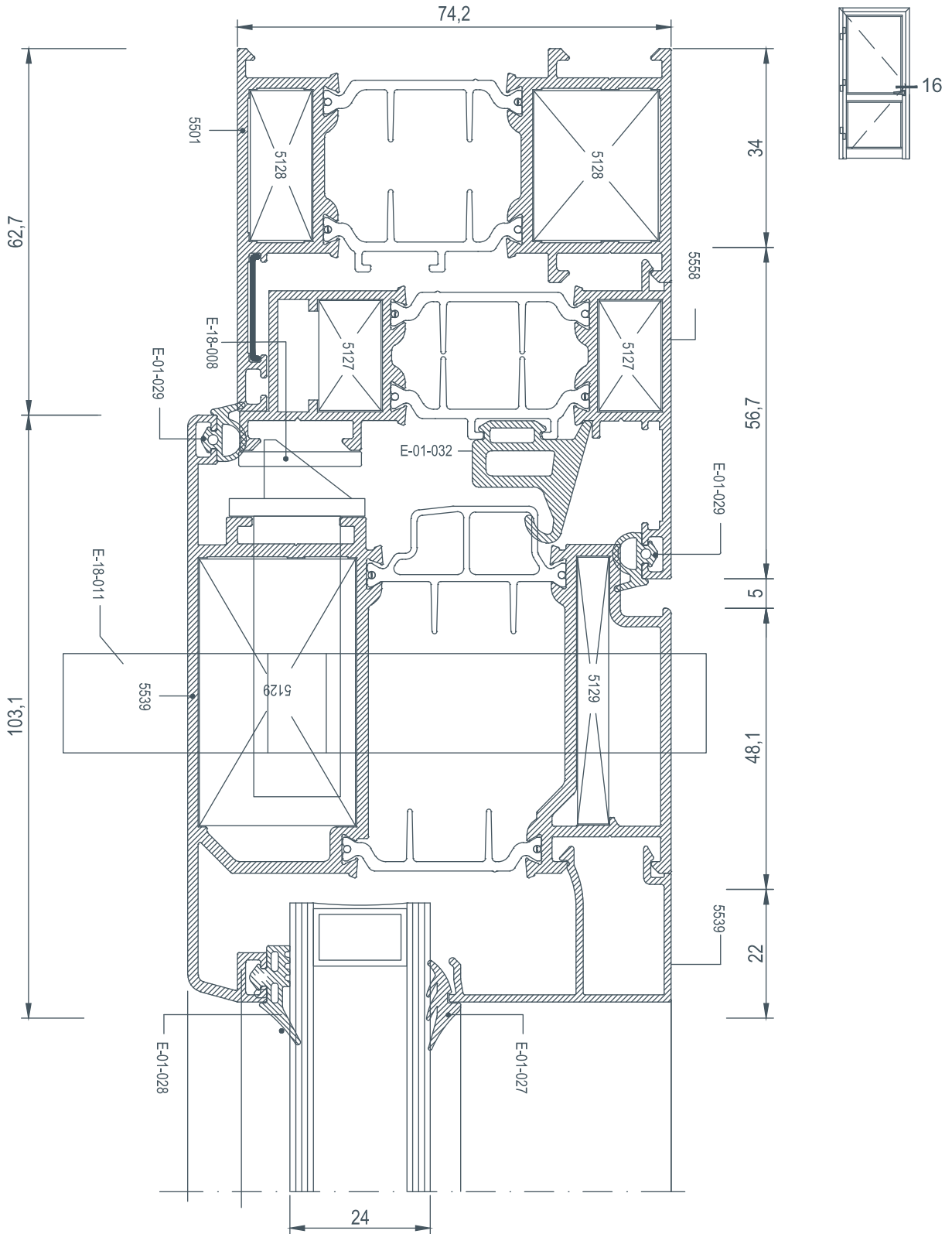

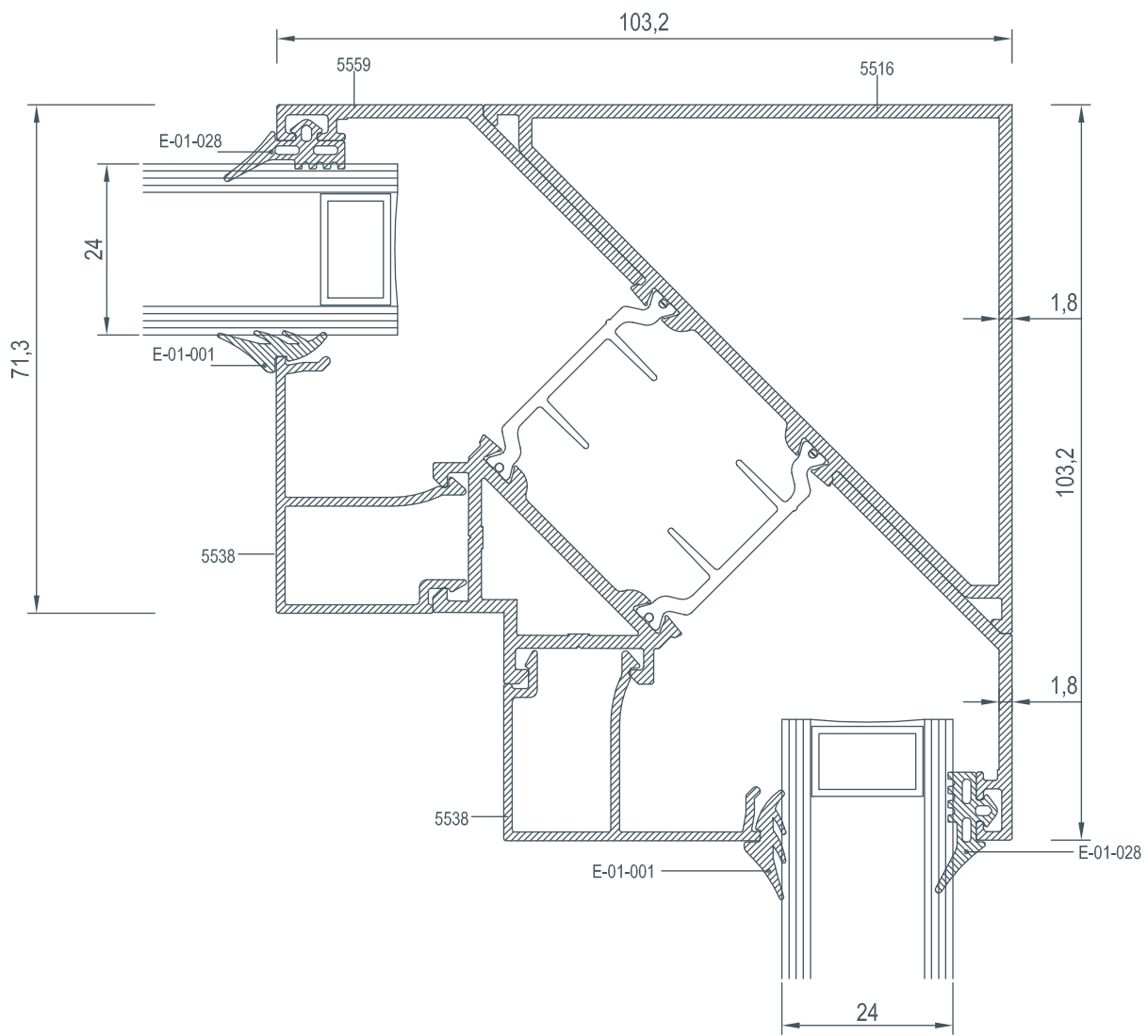
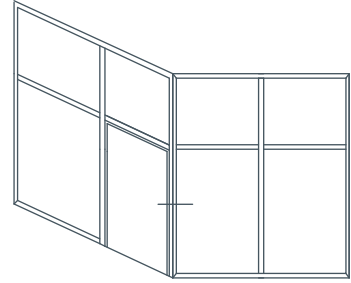

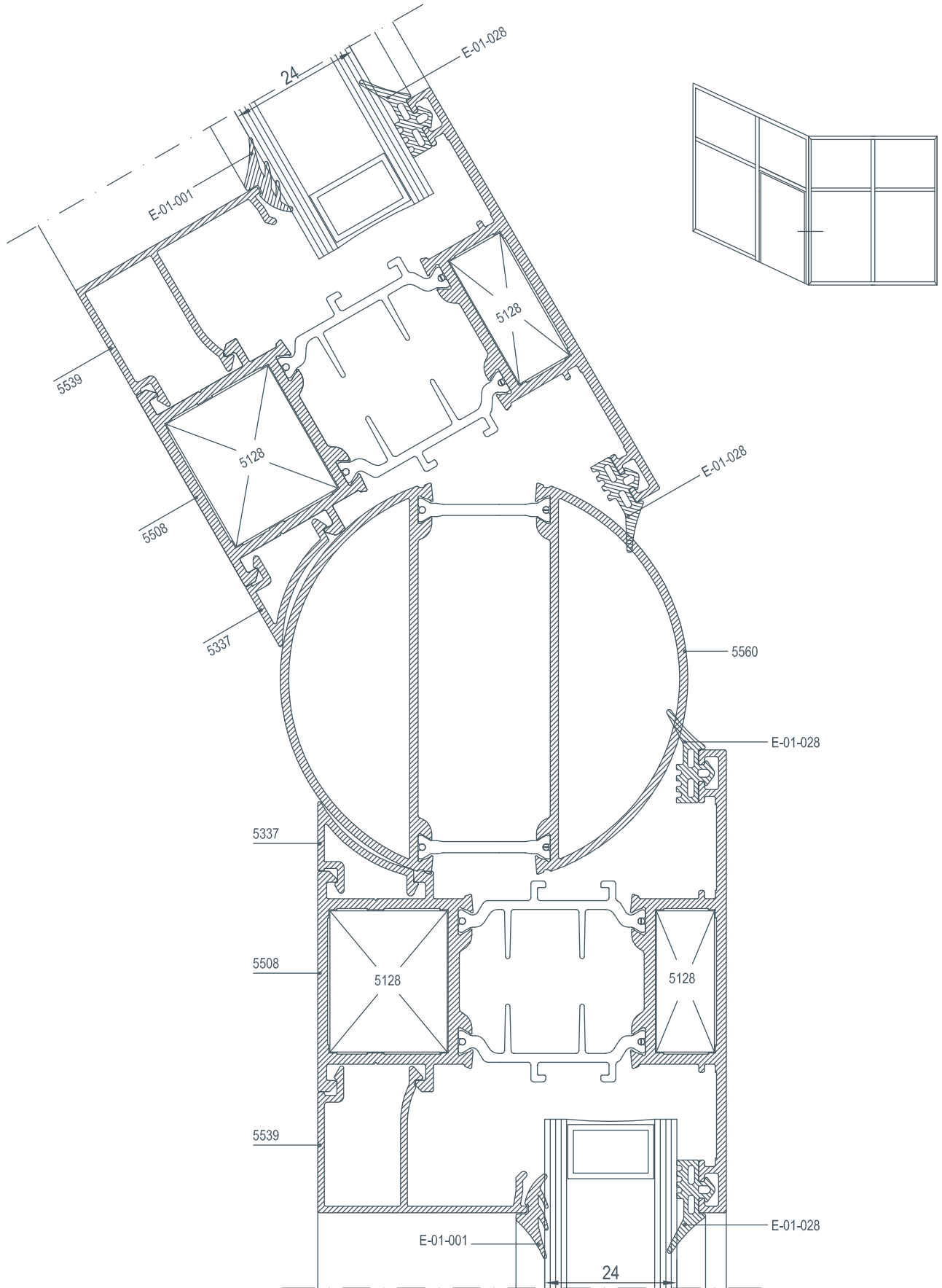

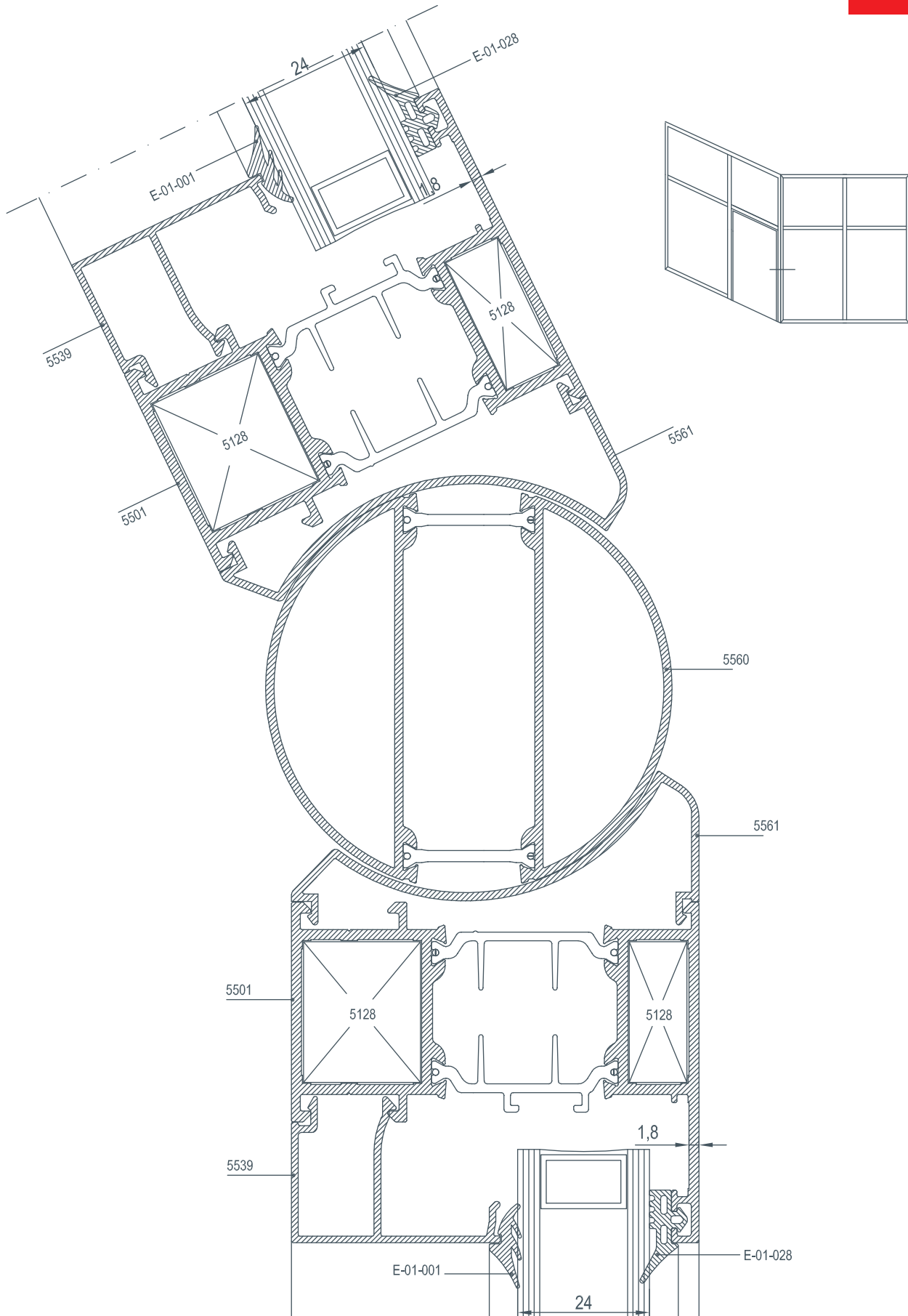









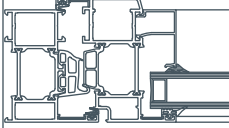
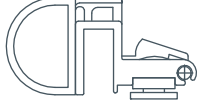
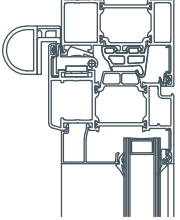

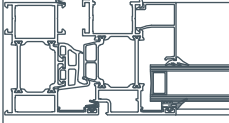
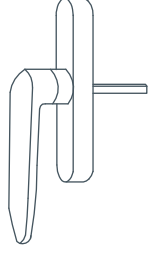
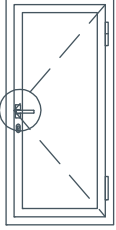
E 74

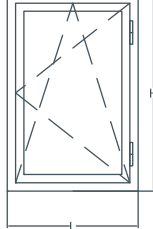
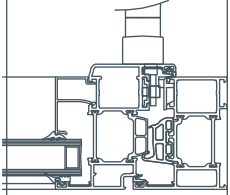
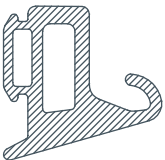
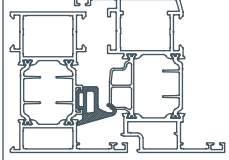
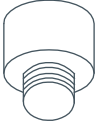
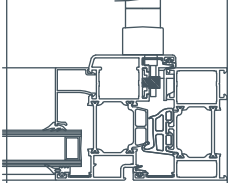
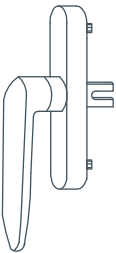
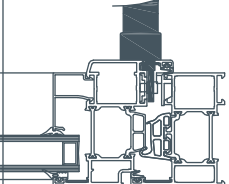
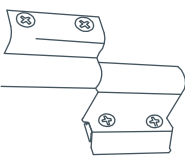
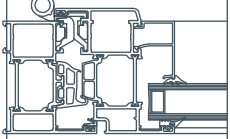
AKSESUARLAR
ACCESSORIES

	<p>E-01-001</p> <p>3mm iç cam fitili 3mm gasket</p> <p>45 gr/mt</p>			<p>E-07-004</p> <p>Vasistas Mandal Vasistas Spring</p>	
	<p>E-01-028</p> <p>Dış cam fitili outside gasket</p> <p>60 gr/mt</p>			<p>E-07-005</p> <p>Kapı Kolu Door Handle</p>	
	<p>E-01-029</p> <p>Dış Bini Fitili Acoustical Gasket</p> <p>40 gr/mt</p>			<p>E-07-006</p> <p>Çift Açılım Mekanizması Tilt and Turn Mechanism</p> <p>L: 570~1000 mm H: 400~1200 mm</p>	
	<p>E-01-032</p> <p>Tozluk Fitili Central gasket</p> <p>276 gr/mt</p>			<p>E-13-002</p> <p>Tij Pimi Lock Pin</p>	
	<p>E-07-003</p> <p>İspanyolet Kol Window handle</p>			<p>E-15-001</p> <p>Pencere Menteşesi Window Hinge</p>	

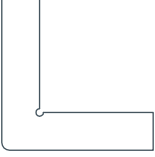
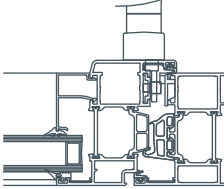
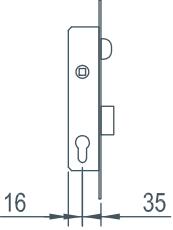
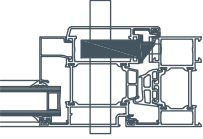
	<p>E-15-004 Kapı Menteşesi Door Hinge</p>		 <table border="1"> <thead> <tr> <th>A</th> <th>B</th> <th>L</th> </tr> </thead> <tbody> <tr> <td>35</td> <td>65</td> <td>90</td> </tr> </tbody> </table>	A	B	L	35	65	90	<p>E-18-011 Barel Cylinder</p>	
A	B	L									
35	65	90									
	<p>E-15-007 Pivot Menteşe Pivot Hinge</p>			<p>E-18-009 Dilli Kilit Mortise Lock</p>							
	<p>E-15-006 Kapı Menteşesi Door Hinge</p>			<p>E-18-008 Dilli Kilit Karşılığı Forend</p>							
	<p>E-17-003 Kapı Altı Fırçası Brush 1 Mt</p>			<p>E-23-002 Vasistas Makas Vasistas Accessory</p>							
	<p>E-18-005 Ayarlı Pim Karşılığı Lock Plate</p>			<p>E-10-001 Köşe Çavuşu Corner joint</p>							

	<p>STP-274001 Köşe Çavuşu Corner joint</p>				
	<p>E-18-009-1 Makaralı Kilit Roller Lock</p>				
	<p>E-18-008-1 Makaralı Kilit Karşılığı Roller Forend Lock</p>	